



VEHICLE	KIT	CROSSBAR
Mazda BT50 Gen2 Dual Cab (single FRONT bar)	DK294F	SZ126
<b>RUNNING DATES</b>	2011- 2020	
<b>VEHICLE NOTES</b>		

VISIT THE ONLINE CALCULATOR FOR CURRENT SYSTEM LOAD LIMIT DATA



**DYNAMIC ROAD LOAD LIMIT** (NOTE: DIFFERENT ON AND OFF ROAD CARGO LIMIT)  
**\*USE THE VEHICLE MANUFACTURER'S MAXIMUM ROOF ALLOWANCE IF IT IS LOWER THAN THE FIGURE LISTED**

 LOAD LIMIT	 SYSTEM WEIGHT	 ON ROAD CARGO LIMIT	 OFF ROAD CARGO LIMIT (ON ROAD CARGO LIMIT / 2)
UP TO <b>35 kg</b> * <b>77 lb</b>	<b>− 2.5 kg</b> <b>6 lb</b>	UP TO <b>32.5 kg</b> <b>72 lb</b>	UP TO <b>16 kg</b> <b>36 lb</b>

OR

### PAD AND CLAMP DETAILS

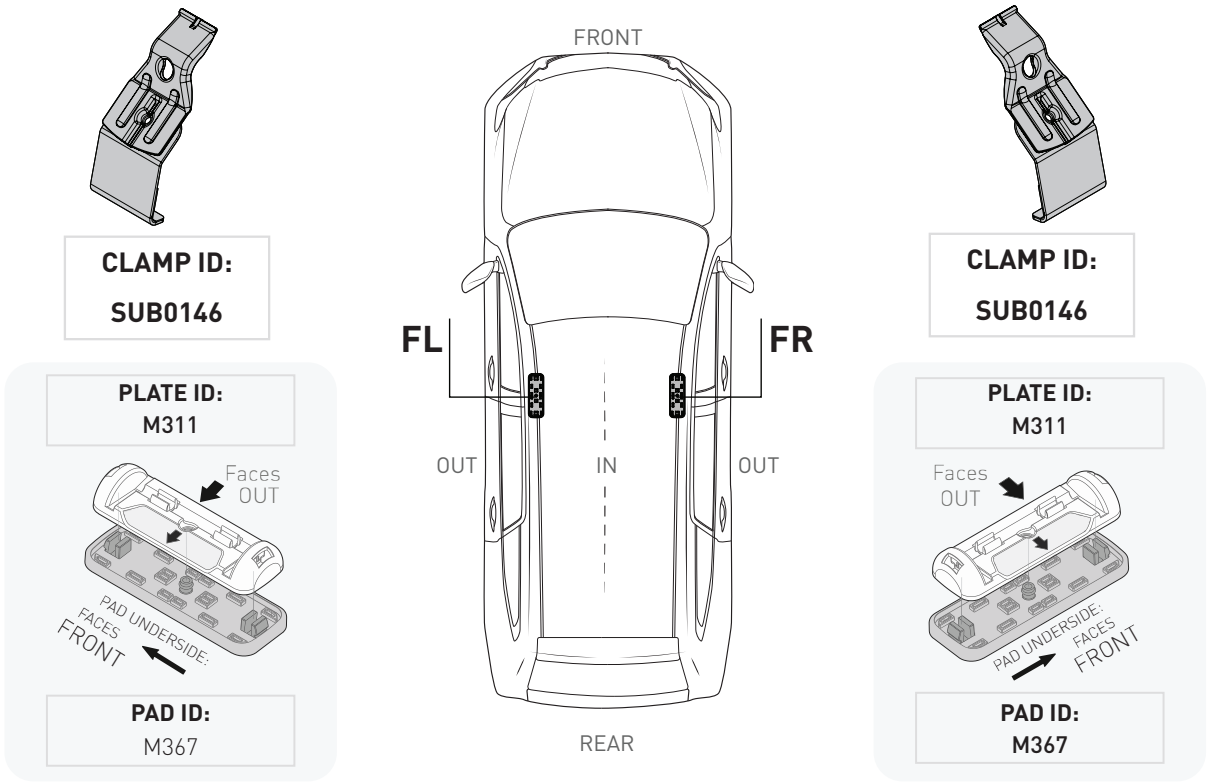

### MEASUREMENT STRIPS

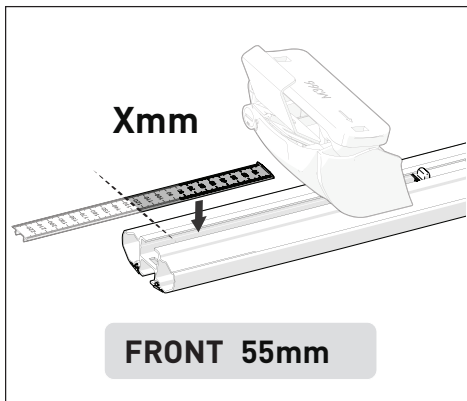

### VEHICLE POSITIONING

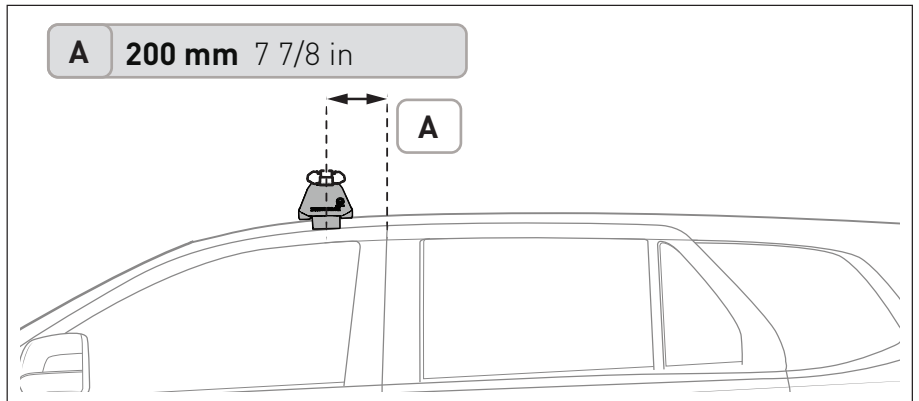

### NOTES FOR DEALERS / FITTERS

It is your responsibility to ensure these fitting instructions are given to the end user or client.