



VEHICLE	KIT	CROSSBAR
Ford F-150 Super Cab Single FRONT	DK150H	SZ150
RUNNING DATES	2009-	
VEHICLE NOTES	See Page 2 for instructions	

VISIT THE ONLINE CALCULATOR FOR CURRENT SYSTEM LOAD LIMIT DATA



DYNAMIC ROAD LOAD LIMIT (NOTE: DIFFERENT ON AND OFF ROAD CARGO LIMIT)
***USE THE VEHICLE MANUFACTURER'S MAXIMUM ROOF ALLOWANCE IF IT IS LOWER THAN THE FIGURE LISTED**

 LOAD LIMIT	 SYSTEM WEIGHT	 ON ROAD CARGO LIMIT	 OFF ROAD CARGO LIMIT (ON ROAD CARGO LIMIT / 2)
UP TO 35 kg * 77 lb	− 2.5 kg 6 lb	UP TO 32.5 kg 72 lb	UP TO 16 kg 36 lb

OR

PAD AND CLAMP DETAILS

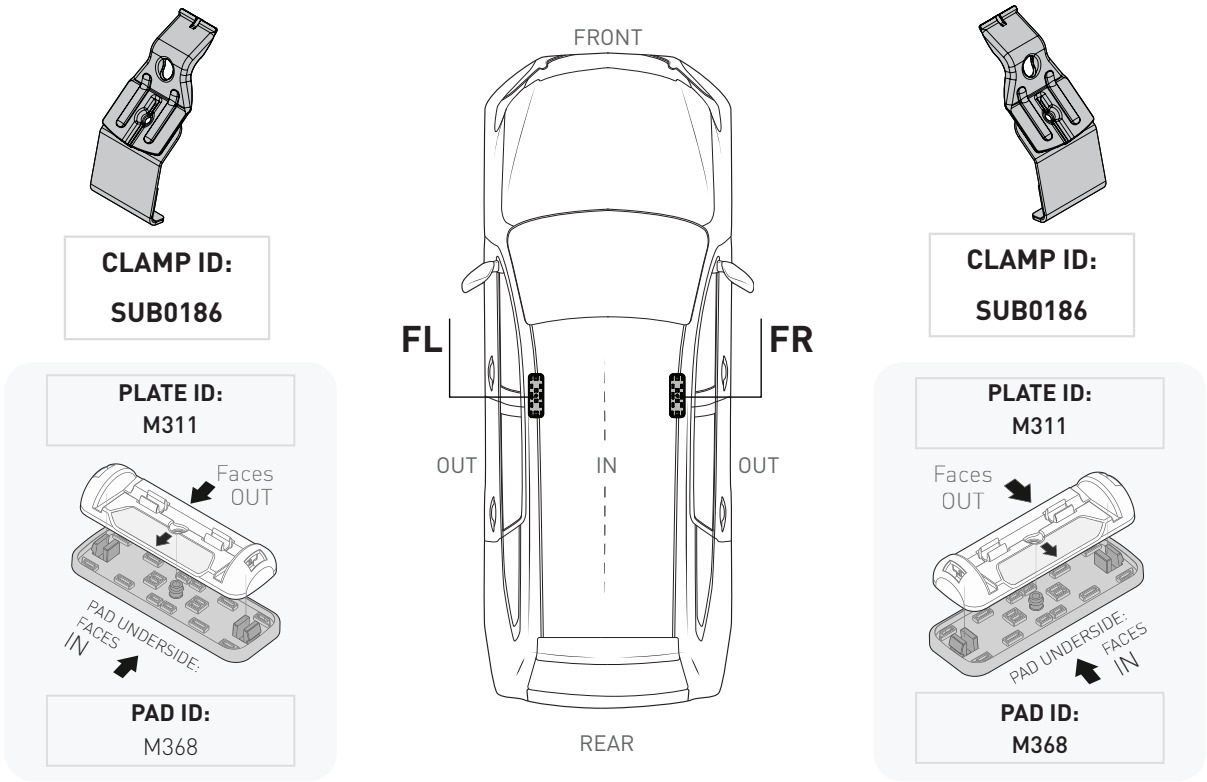

MEASUREMENT STRIPS

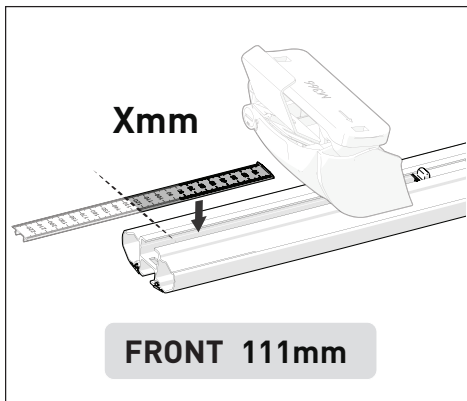

VEHICLE POSITIONING

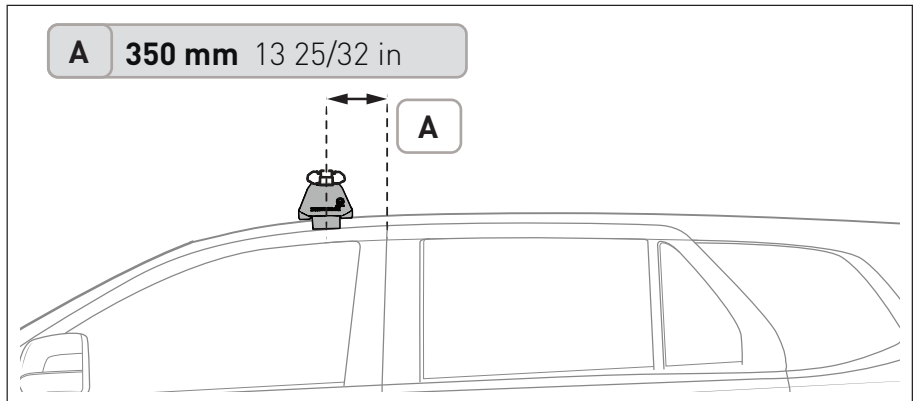



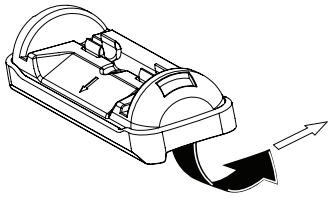
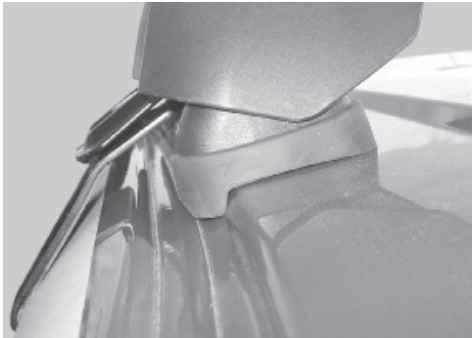

VEHICLE		KIT	CROSSBAR
Ford F-150 Super Cab Single FRONT		DK150H	SZ150
RUNNING DATES	2009-		
VEHICLE NOTES			

Foot Plate ARROW OUT.
ARROW on underside of
Pad faces IN.

Stick clear adhesive tape onto
outside of lower metal strap.

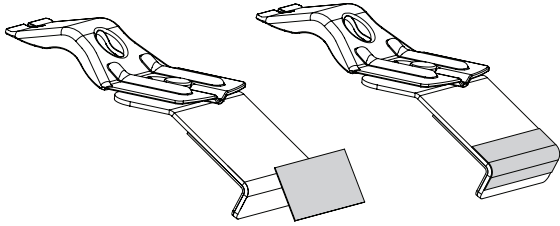
Open door. Pull rubber seal down. Fit clamp.

NOTES FOR DEALERS / FITTERS

It is your responsibility to ensure these fitting instructions are given to the end user or client.