

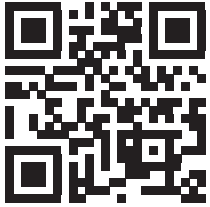

VEHICLE	KIT	CROSSBAR
Isuzu D-MAX Crew Cab	DK131	SZ126
RUNNING DATES	2008-2012	
VEHICLE NOTES		

VISIT THE ONLINE CALCULATOR FOR CURRENT SYSTEM LOAD LIMIT DATA



DYNAMIC ROAD LOAD LIMIT (NOTE: DIFFERENT ON AND OFF ROAD CARGO LIMIT)
***USE THE VEHICLE MANUFACTURER'S MAXIMUM ROOF ALLOWANCE IF IT IS LOWER THAN THE FIGURE LISTED**

UP TO 60 kg * 133 lb	5 kg 11lb	UP TO 55 kg 121 lb	UP TO 27.5 kg 60 lb

OR
OFF ROAD CARGO LIMIT (ON ROAD CARGO LIMIT / 2)

PAD AND CLAMP DETAILS

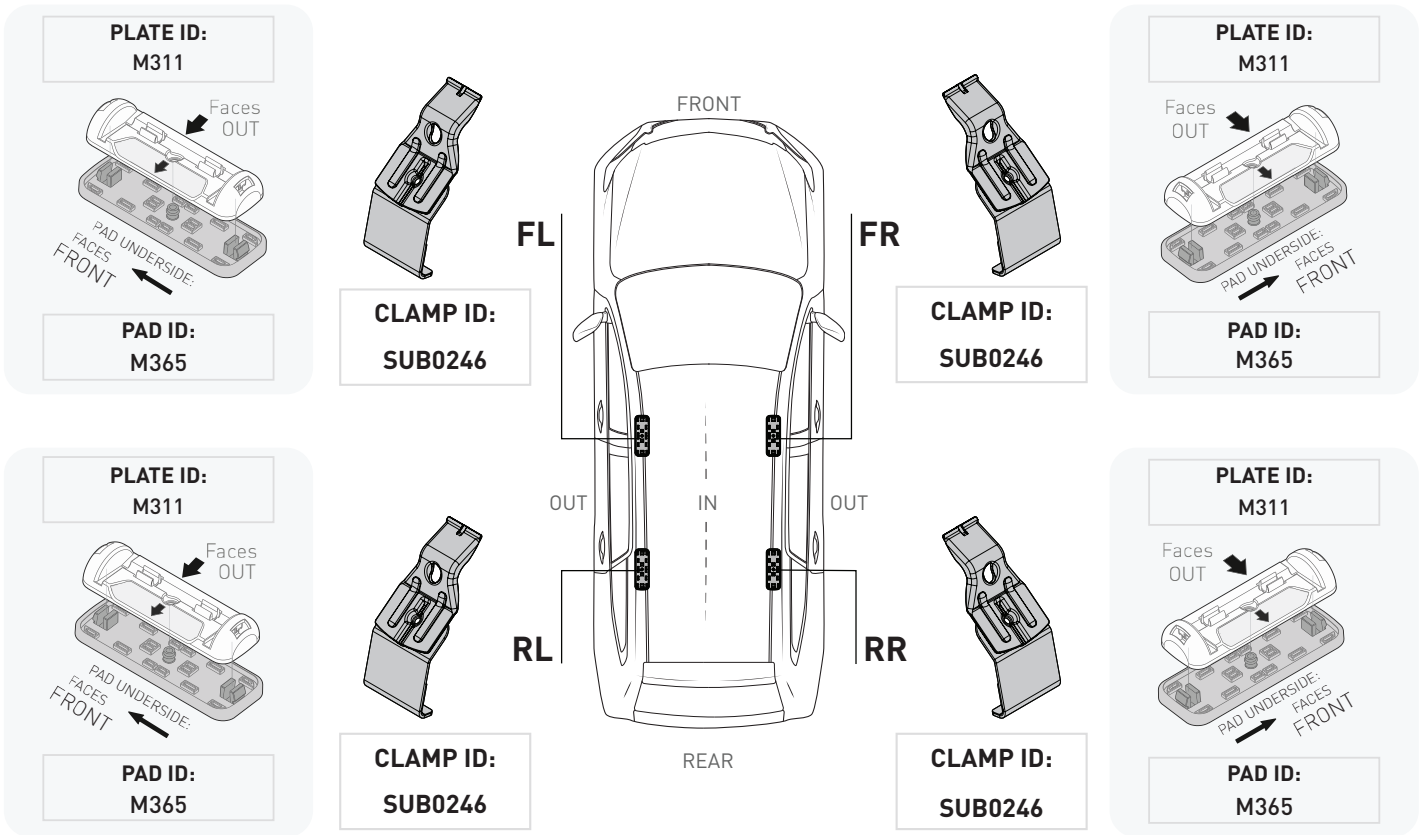

MEASUREMENT STRIPS

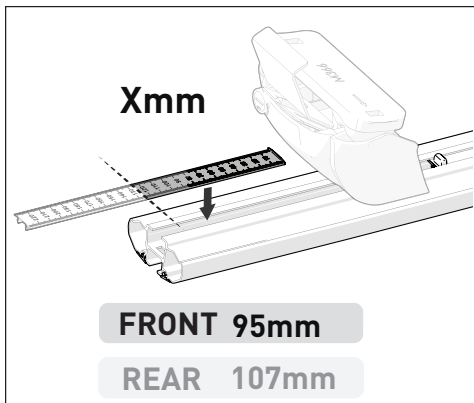

VEHICLE POSITIONING

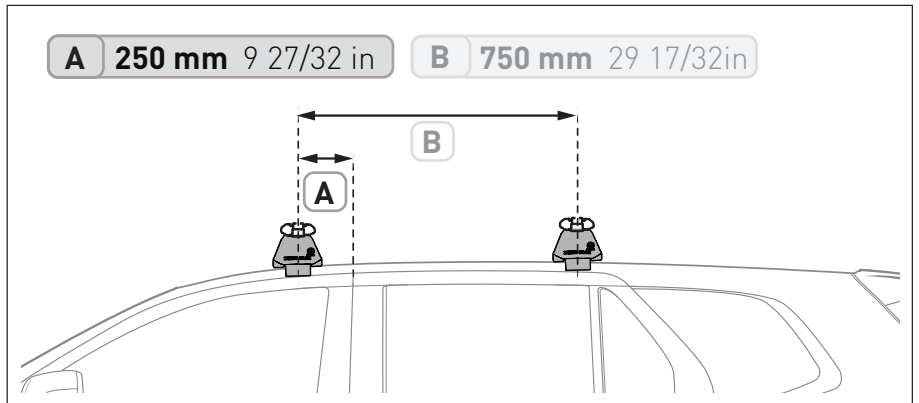

NOTES FOR DEALERS / FITTERS

It is your responsibility to ensure these fitting instructions are given to the end user or client.

Document No: R4280
 Issue No: 1
 Issue Date: 18-Dec-24



VEHICLE		KIT	CROSSBAR
Isuzu D-MAX Crew Cab		DK131	SZ126
RUNNING DATES	2008-2012		
VEHICLE NOTES			

- 1** Open doors. Pull front and rear rubber door seal down to fit metal strap.

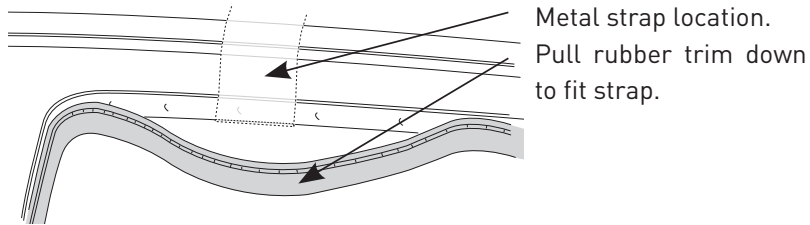

- 2** Re-fit the rubber strip over metal strap.

