



RHINO-RACK

CONTROLLED

Honda HR-V Gen 2 Base kit and leg fitting supplement.

VEHICLE LOAD LIMIT (VLL) KG/LBS	SYSTEM WEIGHT (SW) KG/LBS	ON-ROAD CARGO ALLOW. (OR)	OFF-ROAD CARGO ALLOW. (OFR)
Up to 75/165*	5/11	OR=VLL - SW	OFR = OR/1.5

***CHECK YOUR VEHICLE OWNERS HAND BOOK FOR VEHICLE MAXIMUM CARRYING CAPACITY. PLEASE ENSURE YOU USE THE VEHICLE MANUFACTURERS MAXIMUM ROOF ALLOWANCE IF IT IS LOWER THAN THE FIGURE LISTED IN THIS INSTRUCTION.**

TOOLS REQUIRED:

REFER RCP68-BK INSTRUCTION FOR BASE KIT COMPONENTS AND INSTALLATION TOOLS REQUIRED. **Additional tool: T5 - T30 torx key.**

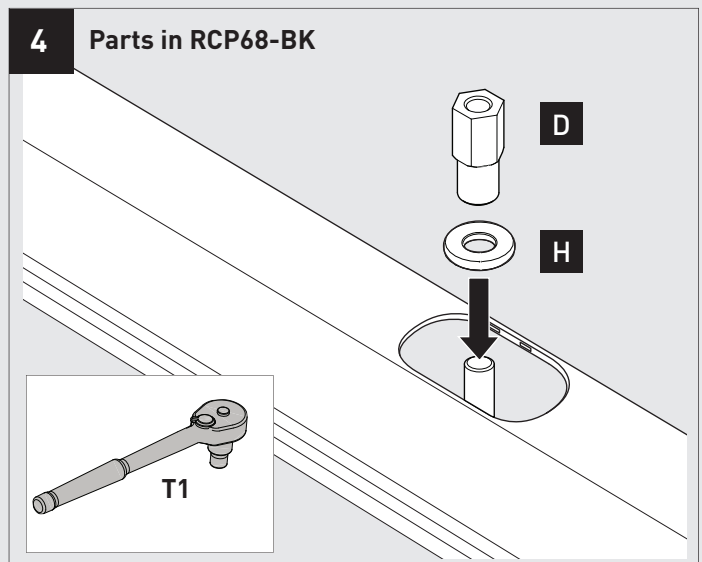
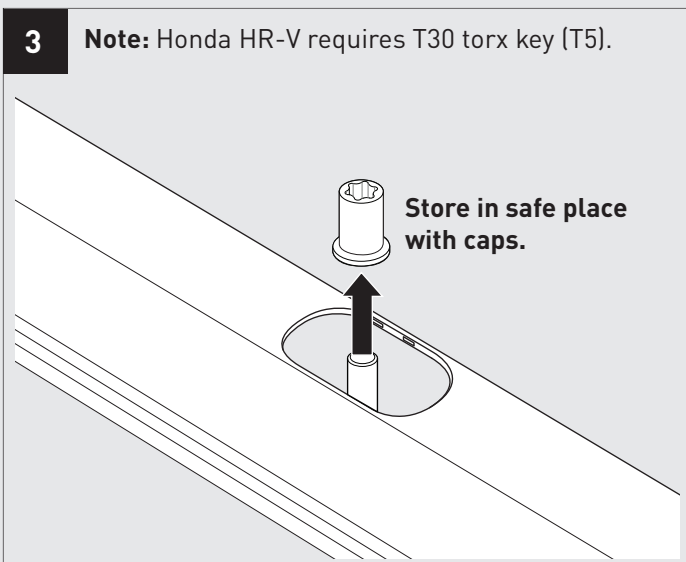
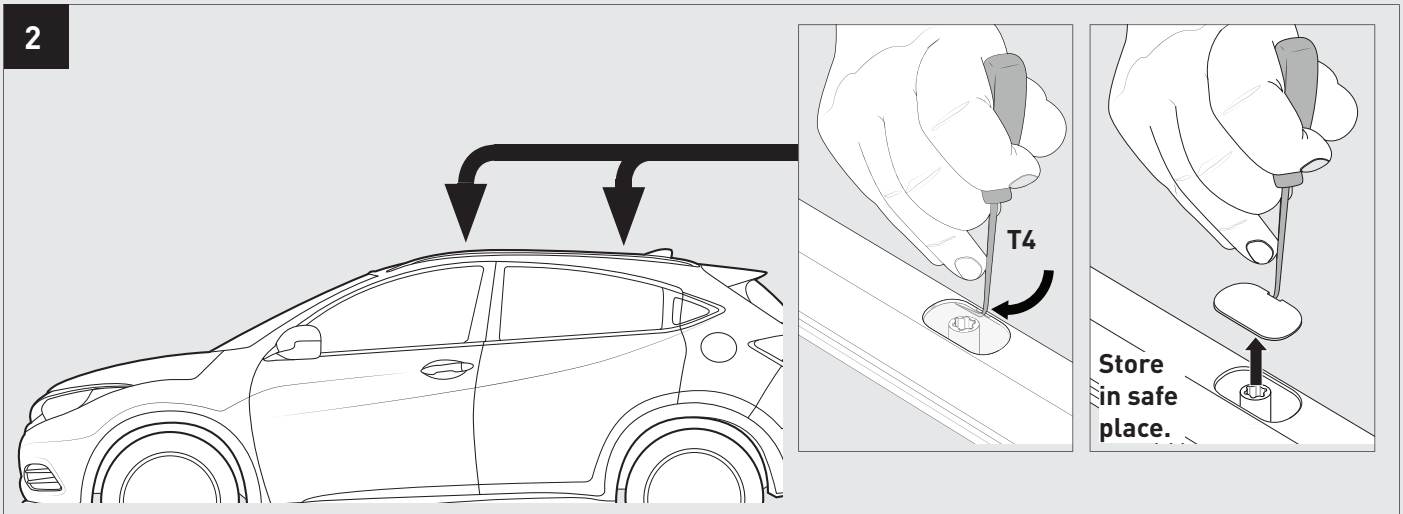
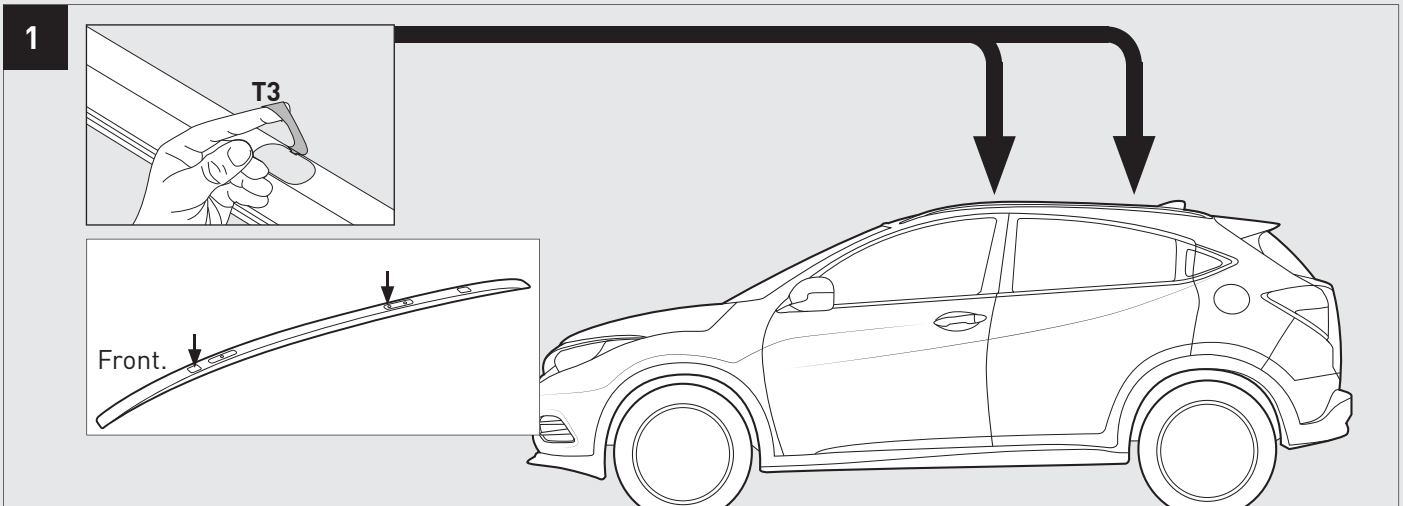

Instructions

5

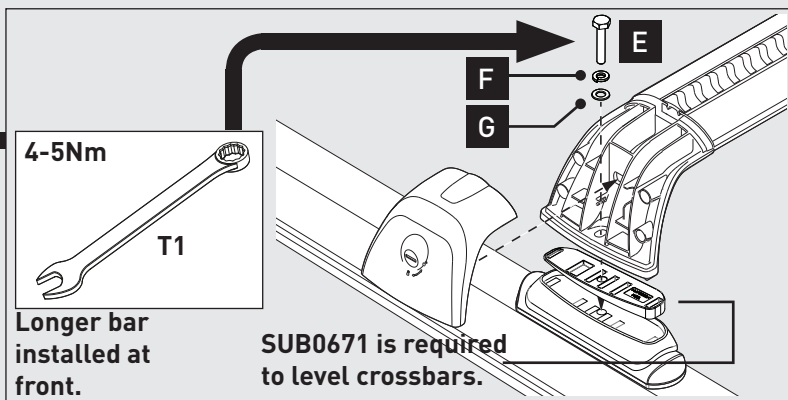
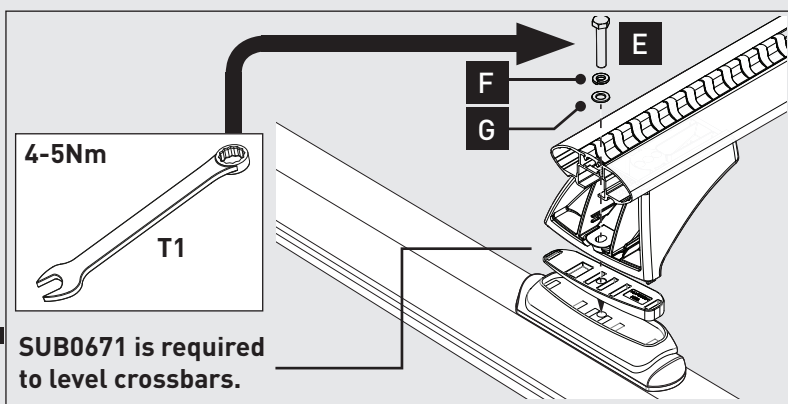
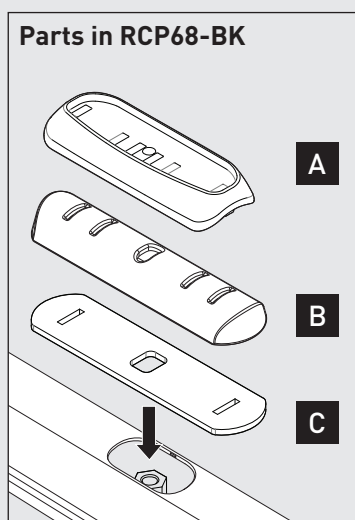
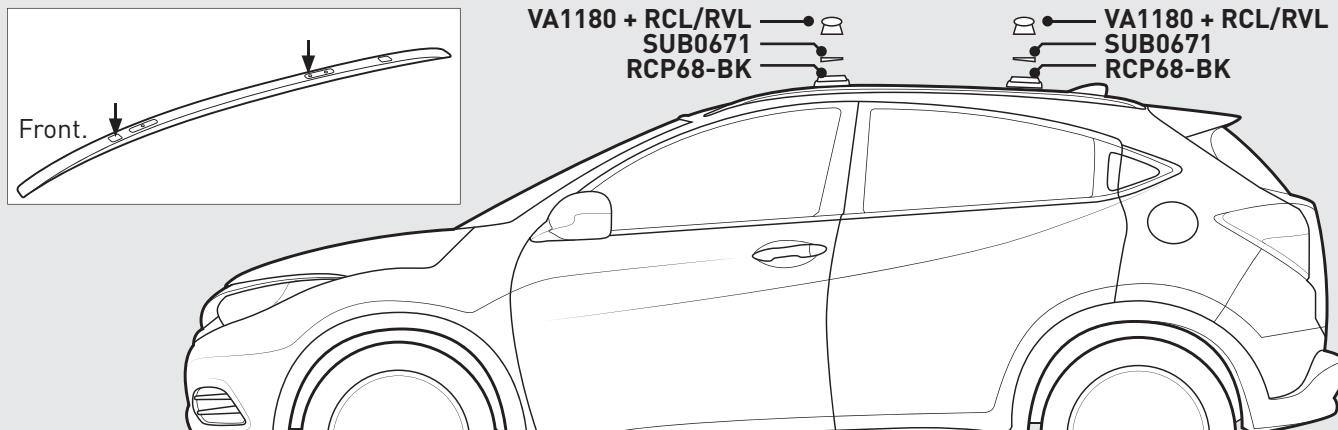

NOTES FOR DEALERS/FITTERS

It is your responsibility to ensure these instructions are given to the end user or client.

Vortex crossbars can be cut to length to fit this vehicle. Measure the desired length out from the centre of the Vortex Bar and create a reference with a marker. Carefully cut the bar at these markings using a Saw with an Alloy Cutting Blade.

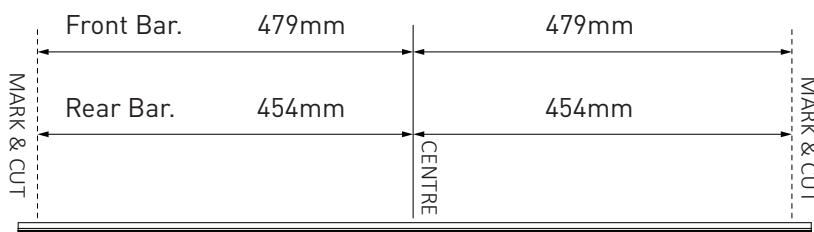

Cut the Bar at the required length.

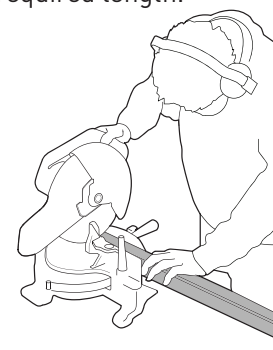

Note for dealers when altering a RSP kits:
 Add 38mm to sports bar measurement for RVL.
 Add 40mm to sports bar measurement for RVH.

Document No: R2502
 Issue No: 01
 Issue Date: 01/07/20

These instructions remain the property of Rhino-Rack Pty Ltd and may not be used or changed for any purpose other than intended.