





# RHINO-RACK

## RVP45 Supplement - Ford Explorer 16

**Important:** Please read these instructions carefully prior to installation.  
 Please refer to your fitting instruction to ensure that the Roof Rack System is installed in the correct location.  
 Check the contents of kit before commencing fitment and report any discrepancies.  
 Place these instructions in the vehicle's glove box after installation is complete.

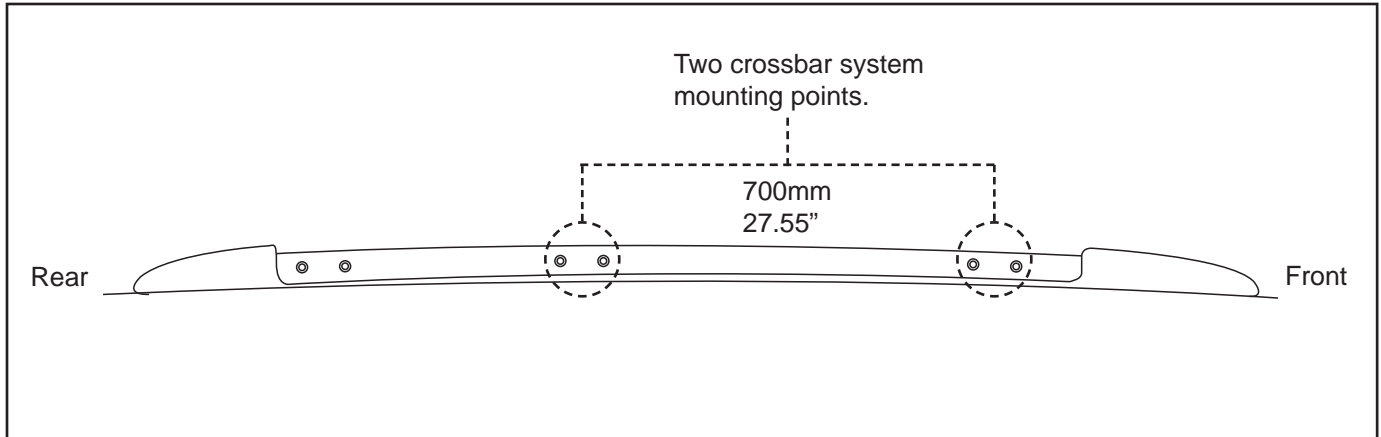
**Maximum load carrying capacity: 75kg/ 165lbs - 2 crossbars.**

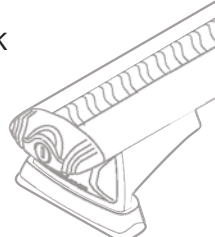
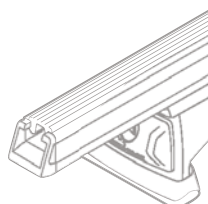

<p><b>Leg kit:</b> RVL4  <b>Front bar:</b> 1106mm  <b>Middle bar:</b> 1085mm  <b>Base kit:</b> RCP45-BK</p> 	<p><b>Leg kit:</b> RCL4  <b>VA Bar:</b> VA150S/B  <b>Base kit:</b> RCP45-BK</p> 	<p><b>Leg kit:</b> RCL4  <b>HD Bar:</b> RB1500S/B  <b>Spacers:</b> QMHD05  <b>Base kit:</b> RCP45-BK</p> 
---	--	--

**Note** Vortex crossbars can be cut to length to fit this vehicle. Measure the desired length out **from the centre of the Vortex Bar** and create a reference with a marker. Carefully cut the bar at these markings using a Saw with an Alloy Cutting Blade.

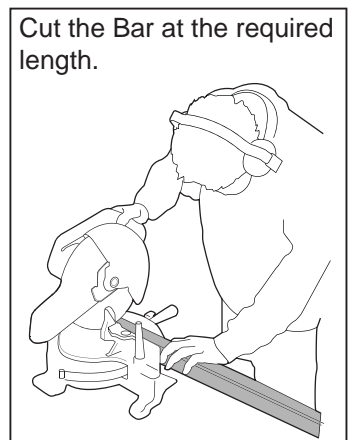
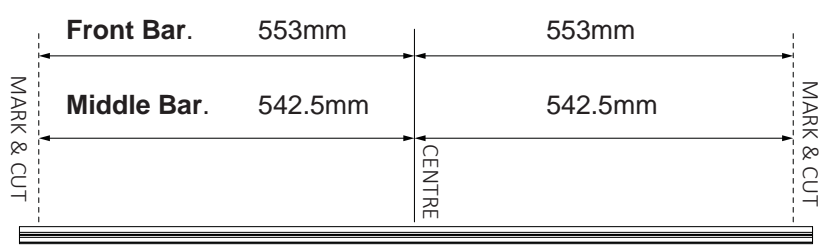

**Note for dealers when altering a RSP kits:**  
 Add 38mm to sports bar measurement for RVL.  
 Add 40mm to sports bar measurement for RVH.

Prepared By: Kayle Everett    Authorised: Chris Murty    Document: R1420    Date: 22/06/17    Issue: 01