

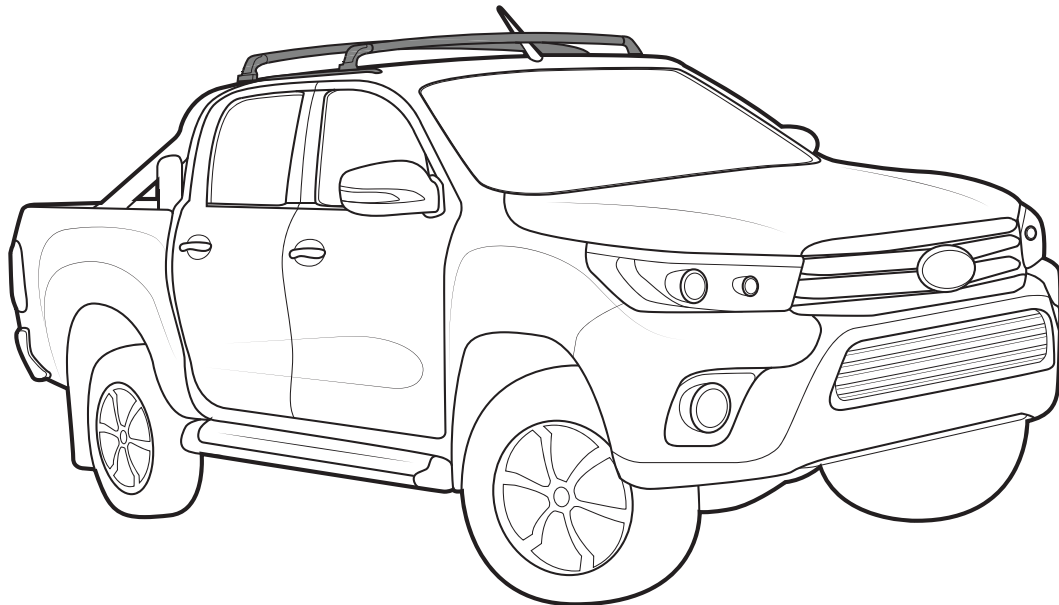

RHINO-RACK

Toyota Hilux Sports Trackmount Kit (RSPT543)

Important: Please read these instructions carefully prior to installation. Please refer to your fitting instruction to ensure that the Roof Rack System is installed in the correct location. Check the contents of kit before commencing fitment and report any discrepancies. Place these instructions in the vehicle's glove box after installation is complete.



Maximum load carrying capacity: 100kg / 220lbs

Important Information

1. Check Part No./Kit is correct 3. Fit roof rack accessory
2. Read through instruction before installing 4. Check and recheck all fasteners are secure

Maximum carrying capacity: 100kg (220lbs) including the weight of the rack system.

Please refer to your vehicle manufacturers handbook for maximum carrying capacity. Always use the lower of the two figures. Load must be evenly distributed over the entire basket.

Warning: Do not attempt to fit the rack system to your vehicle unless you fully understand these fitting instructions. Please direct any questions regarding fitting to the dealer from where the roof racks were purchased.

Use only non-stretch fastening ropes or straps.

Recommendations: It is essential that all bolt connections be checked after driving a short distance when you first install your roof racks. Bolt connections should be checked again at regular intervals (once a week is enough, depending on road conditions, usage, loads and distances travelled). You should also check the roof racks each time they are re-fitted. Always make sure to fasten your load securely. Please also ensure that all loads are evenly distributed and that the centre of gravity is kept as low as possible and must be entirely contained within the extents of the roof racks. **Rack System must be removed when putting vehicle through an automatic car wash.**

Caution: The handling characteristics of the vehicle changes when you transport a load on the roof. For safety reasons we recommend you exercise extreme care when transporting wind-resistant loads. Special consideration must be taken into account when cornering and braking.

Off-road use:

The Track Rack System may be used in off road applications, however a safety factor of 1.5 is enforced. That is, maximum permissible off road load is **66kg (145lbs)**. Although the crossbars are tested and approved to AS1235-2000/ ISO11154, off-road conditions can be much more rigorous. Extreme care must be taken in off road conditions

Note for Dealers and Fitters:

It is your responsibility to ensure these fitting instructions are given to the end user or client.

Rhino-Rack 3 Pike Street, Rydalmere,

NSW 2116, Australia.

(Ph) (02) 9638 4744

(Fax) (02) 9638 4822

Document No: R897

Prepared By: Kayle Everett

Authorised By: Chris Murty

Fit Time: 1.5 Hours

Issue No: 02

Issue Date: 23/01/2018

These instructions remain the property of Rhino-Rack Australia Pty. Ltd. and may not be used or changed for any other purpose than intended.



Toyota Hilux Sports Trackmount Kit (RSPT543)

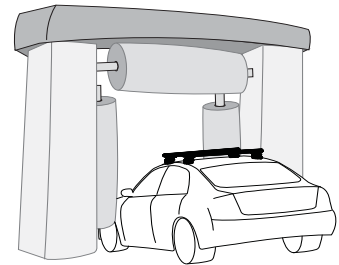
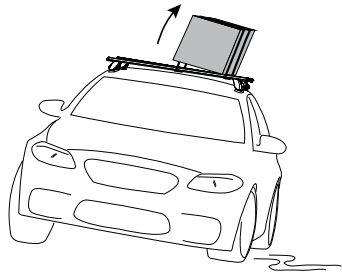
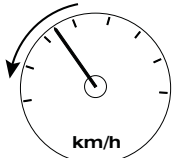
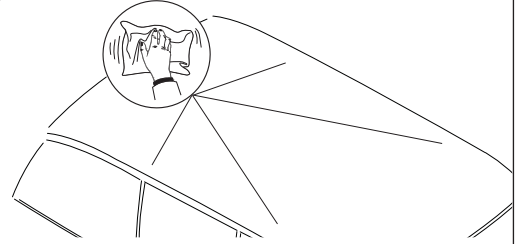
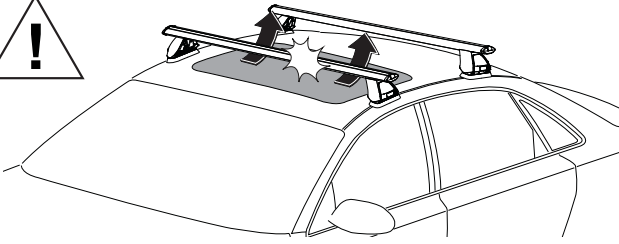
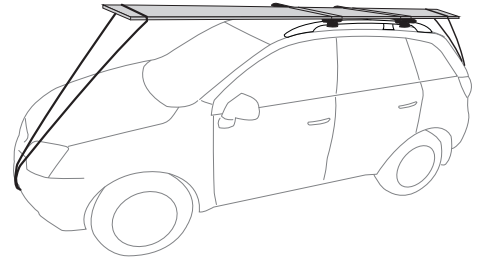
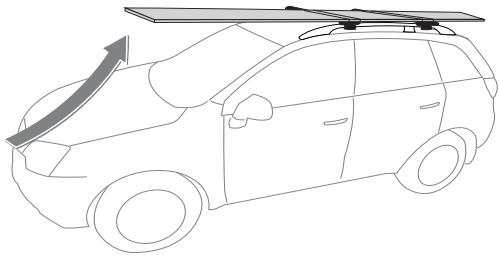

Ensure Ladder is well supported on the ground to help support tent. Take extreme caution when climbing heights above 1.2m/4ft.



? kg

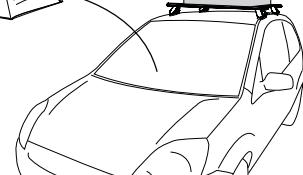

When these roof racks are to be used on a vehicle that is driven off sealed roads, the manufacturer maximum roof load rating (to be found in the vehicles User Manual) should be **divided by 1.5**. Do not forget to subtract the complete crossbar system weight from your maximum carrying capacity.

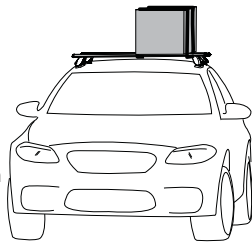

100kg/220lbs
(Urban Road)



66kg/145lbs
(Off Road)

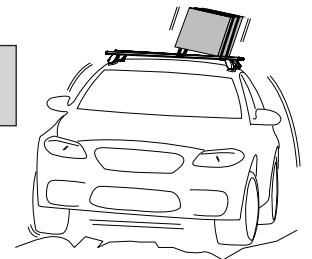

WARNING! Important Load Carrying Instructions

With utility vehicles, the cabin and the canopy move independently. Roof racks and vehicle can be damaged if the item transported is rigidly fixed at points on both the cabin and canopy. Instead, rigidly fix to either the cabin roof racks or the canopy roof racks.

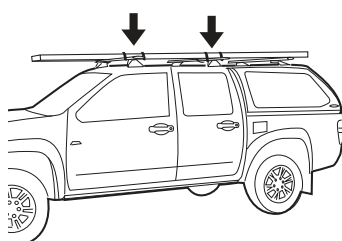
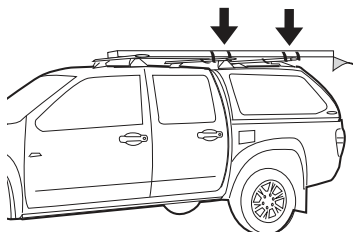

Paddle/ Surfboards should be fixed to the front of the vehicle.

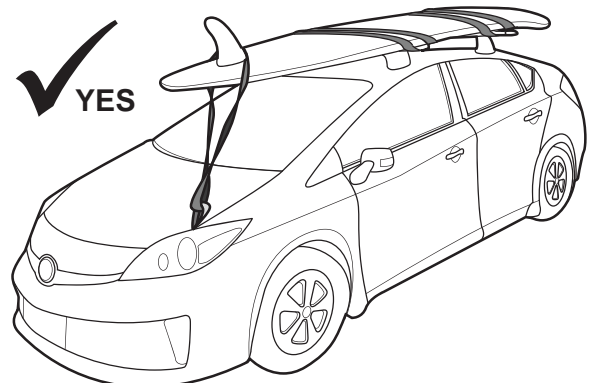



Toyota Hilux Sports Trackmount Kit (RSPT543)

Parts List

Item	RSPT-FK1 Kit	Qty	Part No.
1	Vortex Generating Strip	6	M626
2	Crossbar VA - F/R 957mm	2	A763
3	M6 x 40mm Socket HD Cap Screw	4	B033
4	M6 Spring Washer	4	W004
5	M6 x 16mm Flat Washer	4	W031
6	Top Pad	4	M172
7	Bottom Pad	4	M173
8	Dowel Nut Housing	4	A341
9	M6 x 16mm Dowel Nut	4	N027
10	Instructions	1	R896
RSPT543 Included Kits			
11	Locking RVP Leg Kit	1	RVL4
12	Track Mount Kit	1	RTS543

Note: RSPT543 includes -
1x RSPT-FK1
1x RVL4
1x RTS543

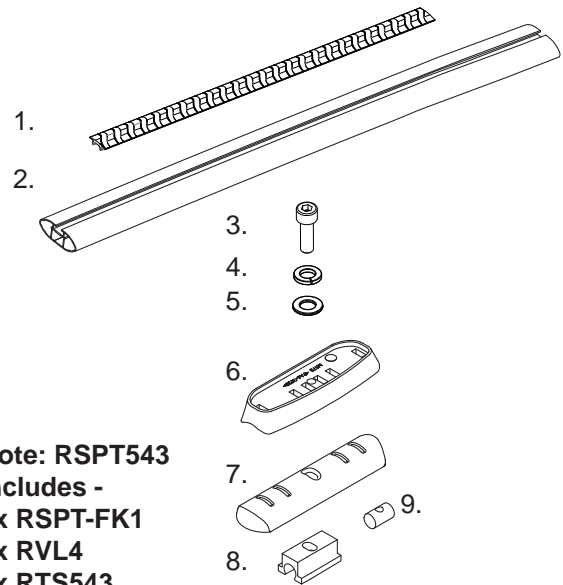

Tools Required:

1: Allen Key (provided). 2: Phillips Head Screw Driver. 3: Metal Key (provided). 4: Drill with 4mm/5mm Drill Bit. 5: Cold Galvanising Paint. 6: Cotton Buds. 7: Clean Cloth. 8: Vacuum. 9: Marker. 10: Measuring Tape.

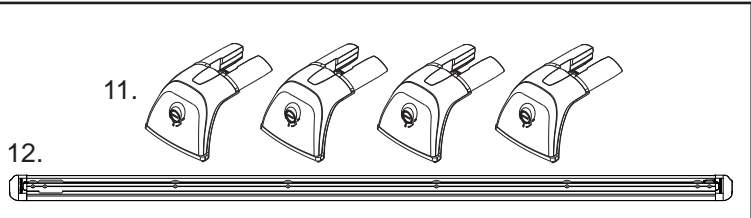

Instructions

1 Install the RTS543 Track Mount Kit as per instructions enclosed with the Tracks (R835).

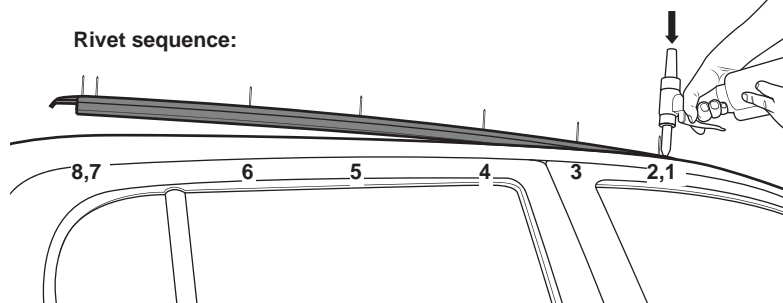

Note: The Track will stand high at the rear when installing from the front. Minor force will be needed to flex the Track down while riveting.

2 Place the Dowel Nuts into the Housings. Slide the Dowel assemblies into the rear of the Tracks using the slots. Sit the Top Pads onto the Bottom Pads and place above the Dowel Housings in the Tracks.

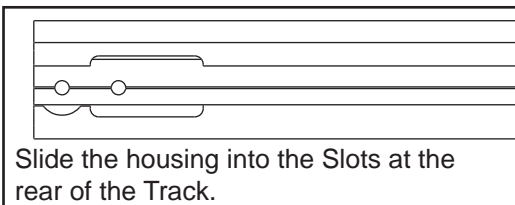

Top View: Inserts in the Top Pad face the outside of the vehicle.

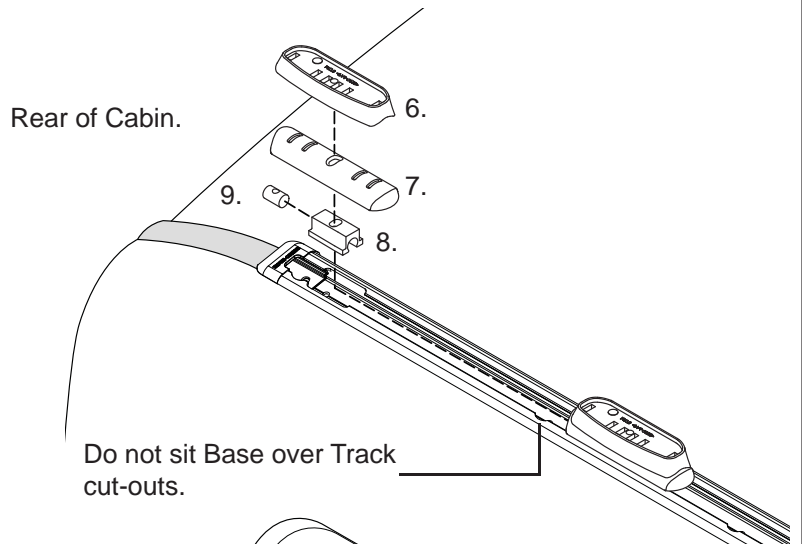
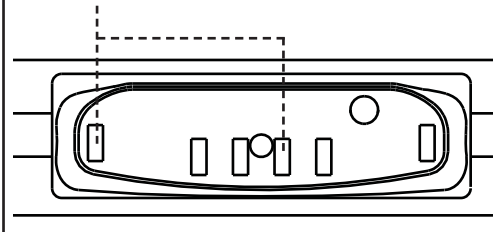



Toyota Hilux Sports Trackmount Kit (RSPT543)

- 3** Assemble the Crossbars as per instructions located in RVL4. Sit the Crossbar assembly on the Top Pad. Place the M6 Socket Screw and Washers through the hole in the Leg as shown and screw into the Dowel Nut. Finger tighten.

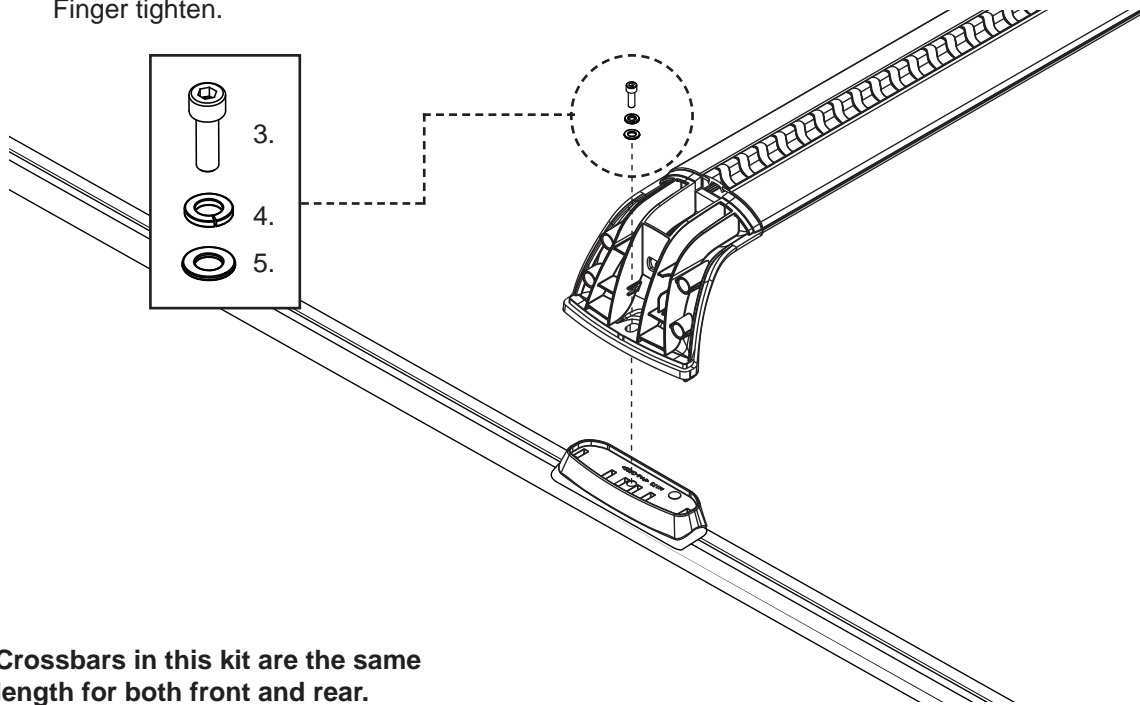

Crossbars in this kit are the same length for both front and rear.

- 4** Position both Crossbars evenly 700mm - 800mm apart. Use the Allen Key provided to tighten the Crossbars in place to 3-4Nm.

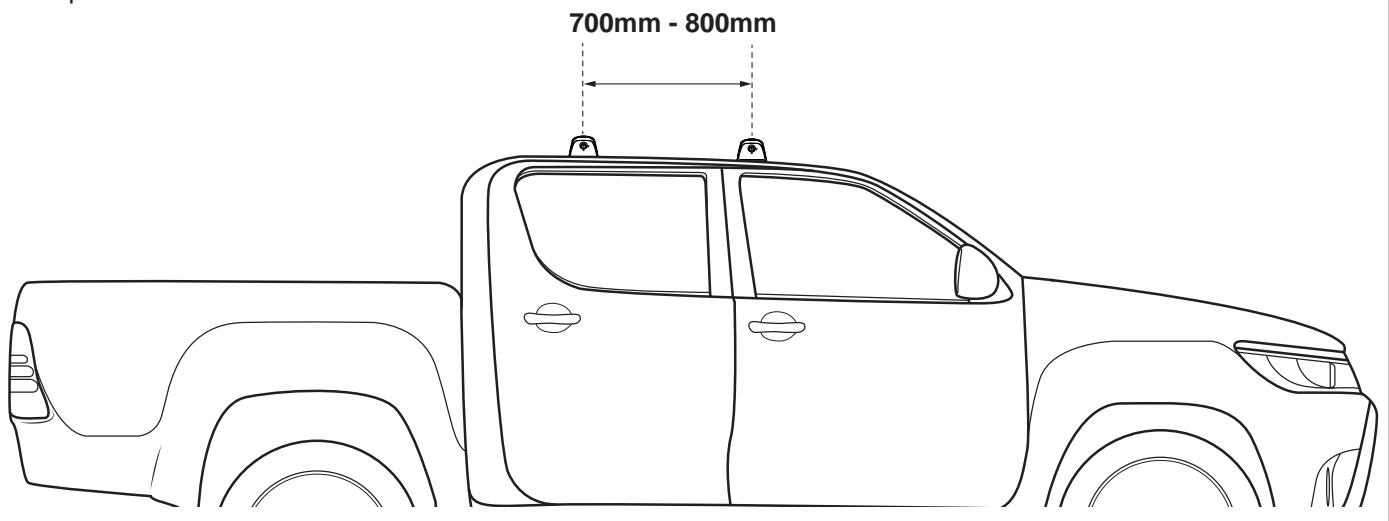

- 5** Replace the RVL4 Allen Key and Cover Plate. Lock with Key provided.

