

# RHINO-RACK®

## Reconn Platform

Toyota 4-Runner

63101

**Important:**

1. Check the Rhino-Rack website to ensure you have the latest issue of these instructions.
2. Please refer to your fitting instruction to ensure that the accessory is installed correctly.
3. Check the contents of kit before commencing fitment and report any discrepancies.
4. Place these instructions in the vehicle's glove box after installation is complete.
5. These instructions must be followed for warranty to be upheld.

**Fit Time:** 90 mins

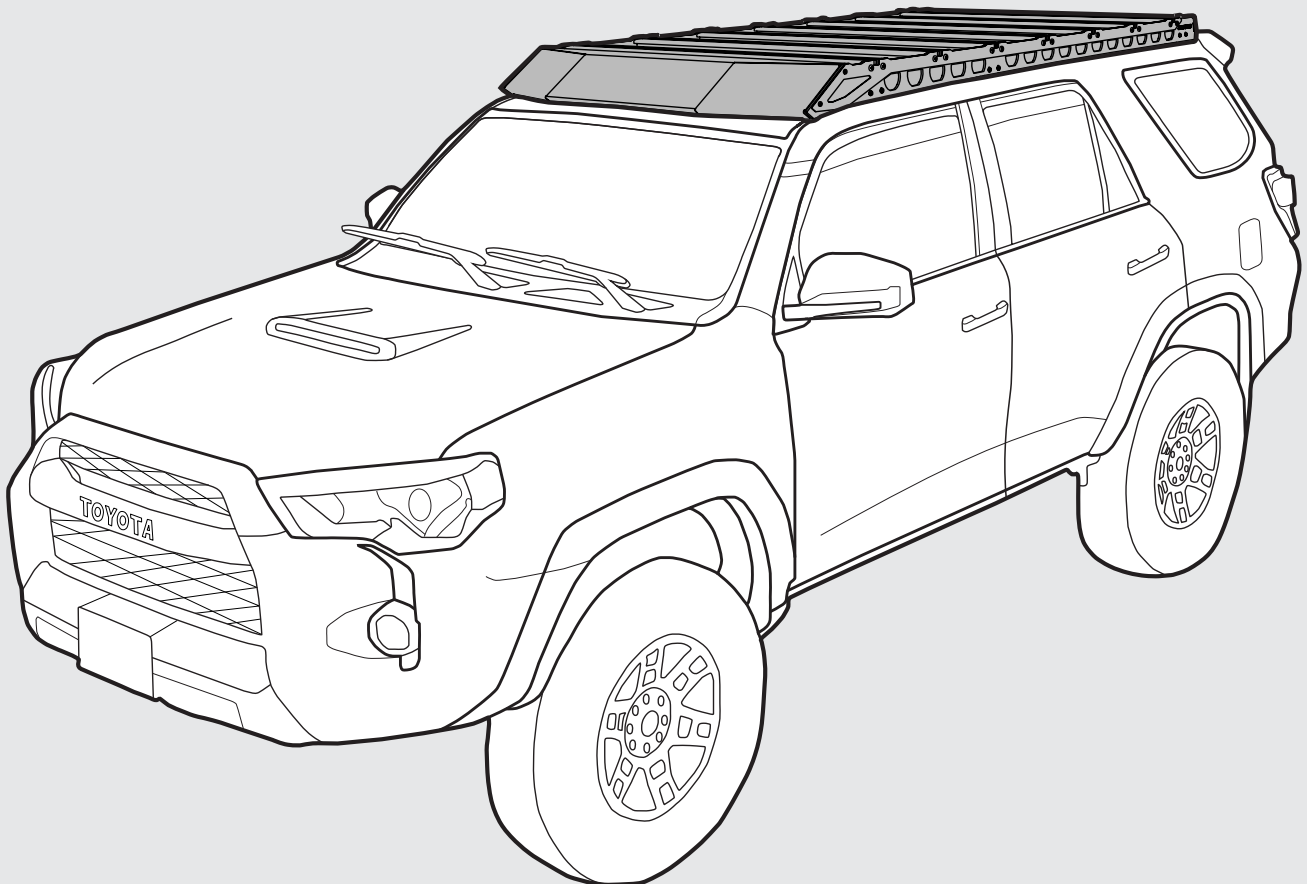

[RHINORACK.COM](http://RHINORACK.COM)



Document No: 520-RFI-00198

Issue No: 01

Issue Date: 09/09/2024

# Toyota 4-Runner

**DYNAMIC LOAD LIMIT:**  
**\*USE THE VEHICLE MANUFACTURER'S MAXIMUM ROOF ALLOWANCE IF IT IS LOWER THAN THE FIGURE LISTED**

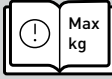
|  |  |  |    |   |
|--|--|--|----|---|
| <br>CARGO | <br>SYSTEM WEIGHT | <br>LOAD LIMIT | OR | <br>Max kg |
| UP TO <b>120KG</b><br><b>263lbs</b>  | +  | <b>30KG</b><br><b>67lbs</b>  | =  | UP TO <b>150 KG</b><br><b>331 lbs</b>   |
|  |  |  |    | *VEHICLE<br>MANUFACTURER'S<br>ROOF LOAD LIMIT   |

 **STATIC LOAD LIMIT: UP TO 250KG / 551LBS\***

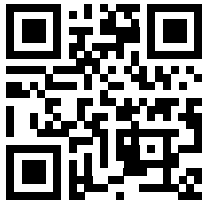

VISIT THE ONLINE  
 CALCULATOR FOR  
 CURRENT SYSTEM  
 LOAD LIMIT DATA

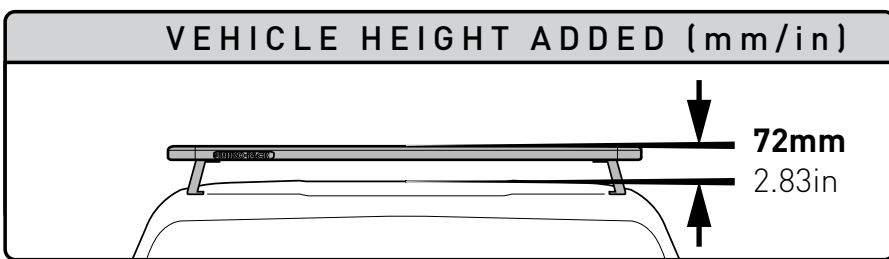

**Exercise extreme care** when transporting wind-resistant loads. Special consideration must be taken when cornering and braking.

Off-road conditions can be much more rigorous. Extreme care must be taken on any driven path that does not contain a surface protection layer (tar/bitumen).

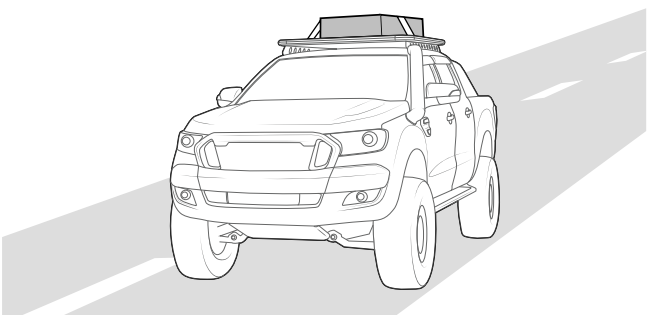
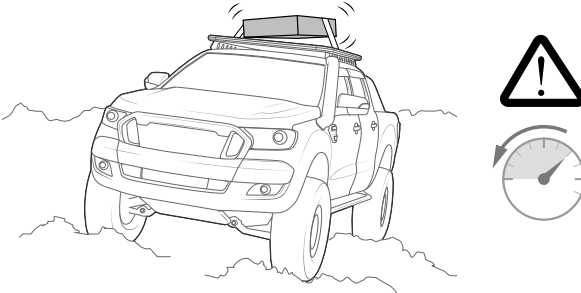

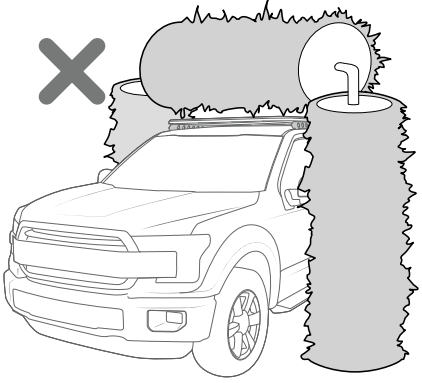



Racks must be removed when vehicle is put through an automatic car wash.

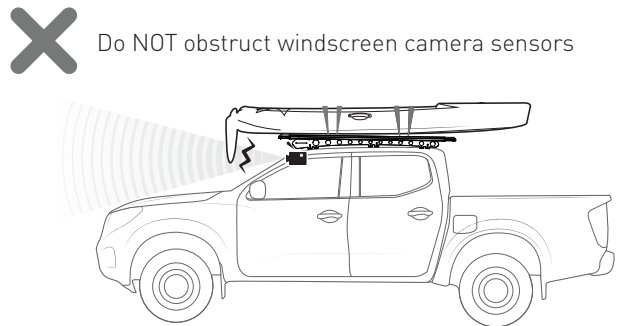

Ensure Ladder is well supported on the ground to support tent. Take extreme caution when climbing heights above 1.2m/4ft.



Do NOT obstruct windscreen camera sensors

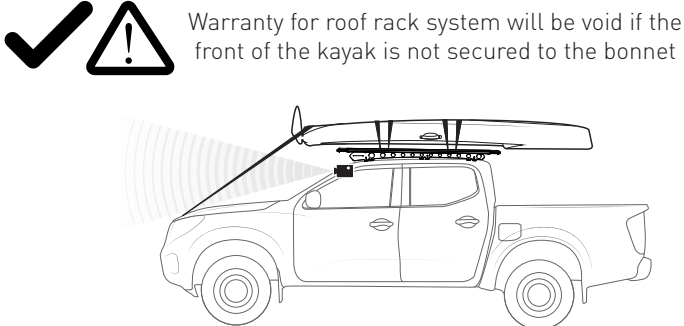

Warranty for roof rack system will be void if the front of the kayak is not secured to the bonnet

Distribute loads evenly and laterally/longitudinally as low as possible over the span.

Avoid point loads concentrated at the front or rear.

Long flexible loads must attach securely to rigid support and be tied down to the bonnet

Surfboard Overhang > 600mm must be tied to the bonnet

Loads must be tied down to Platform, **NOT** around Backbone

Use only non-stretch fastening ropes or straps to attach cargo to roof racks

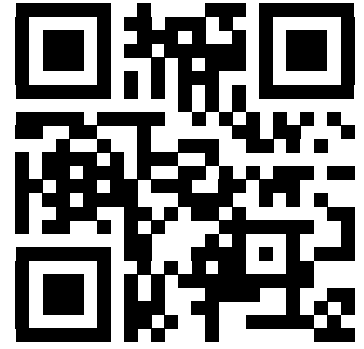

## In service maintenance checks

- All bolts should be checked after driving a short distance when you first install your roof racks to ensure none have loosened.
- All bolted connections should be checked again at regular intervals (weekly is recommended, depending on road conditions, usage, loads and distances travelled).
- All bolted connections should be checked each time they are re-fitted.
- Off-road conditions are more rigorous. Check all bolted connections and your load more regularly.
- Ensure that your total vehicle manufacturer's GVM (gross vehicle mass) and gross axle weights are not exceeded (refer to vehicle owner's manual).

## Note for Dealers and Fitters

It is your responsibility to ensure these fitting instructions are given to the end user or client. These instructions remain the property of Rhino-Rack Australia Pty. Ltd. and may not be changed or used for any other purpose than intended.

## Torque Settings

Throughout this instruction manual, an impact driver can be used to speed up installation. However, it is important to ensure that the final turns are completed with a torque wrench to achieve the required torque rating.

Take caution when using an impact driver, as excessive torque can result in stripped threads.



### Torque Settings:

Unless stated otherwise in these instructions, all fasteners should be set to the following torque settings:

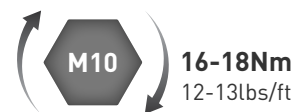

## What you should have

To complete this build/ fit you will need:

### RECONN SYSTEM COMPONENTS

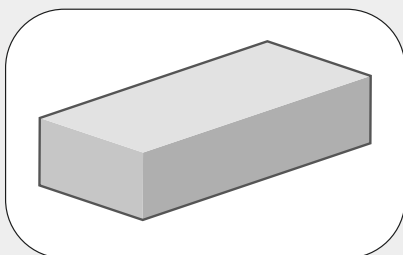

63101 x1

+

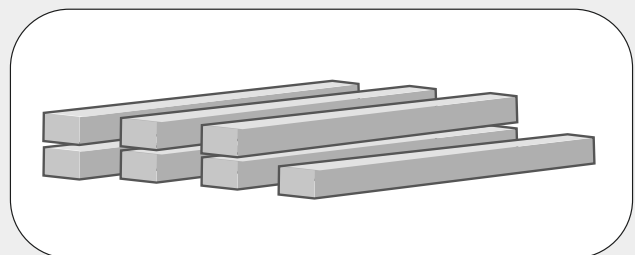

RDB120P x7

Parts List

Blade - Left Side  
**A x1**

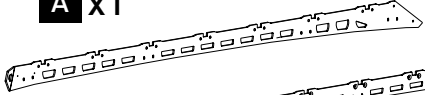

Blade - Right Side  
**B x1**

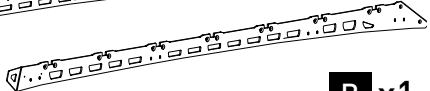

Fairing Weldment  
**C x1**

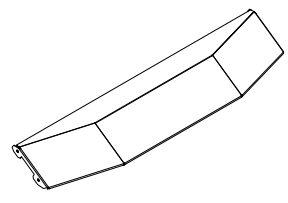

Cast Mounting Block with Gasket  
**D x4**

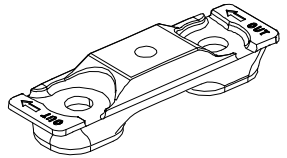

Trim Plate  
**E x2**

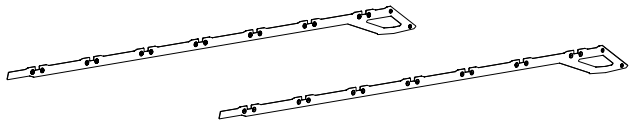

Adhesive Leg  
**F x2**

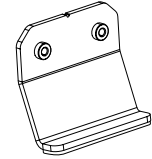

Front Leg  
**G x2**

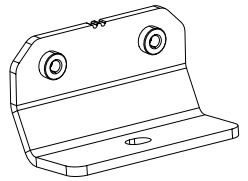

Stiffening Plate  
**H x2**

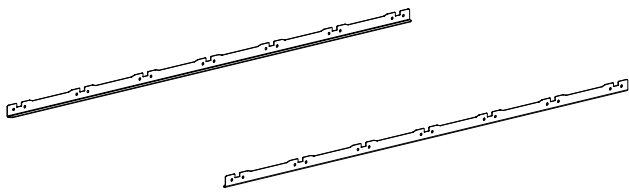

Rear Leg  
**I x2**

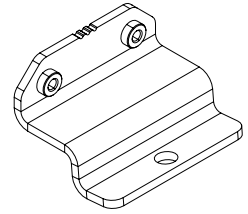

M8 x 12.5mm Flat Washer  
**J x12**

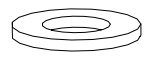

M8 X 40 Torx Socket Tribolular Screw  
**K x28**



M8 X 16 Torx Socket Screw  
**L x12**



M8 x 20 Hex Head Flanged Bolt with T40  
**M x4**

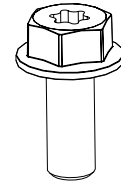

M8 X 35MM Hex Head Flanged Bolt  
**N x8**

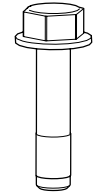

M6 X 16 Torx Socket Screw  
**O x4**



T30 x 100mm Torx Drive 1.4 Hex Driver  
**P x1**



T40 x 100mm Torx Drive 1.4 Hex Driver  
**Q x1**



Instruction  
**R x1**

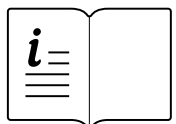

Reconn Deck Bar  
**RDB120P x7**

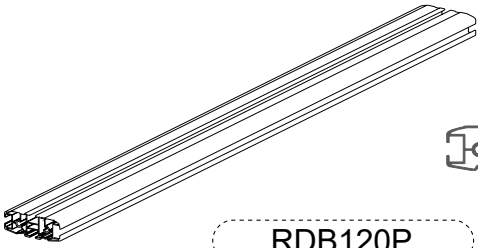

**Tools Required:**

- T1 - Tape Measure
- T2 - Cutting Tool
- T3 - Marker/Pen
- T4 - Flat Head Screw Driver
- T5 - Impact Driver
- T6 - 13mm Socket Wrench
- T7 - Cleaning Rag

- T8 - Pointed Trim Tool
- T9 - Trim Tool - Fork Head
- T10 - 12mm Socket Wrench
- T11 - Torque Wrench

P1  
▼

RAISED RAIL

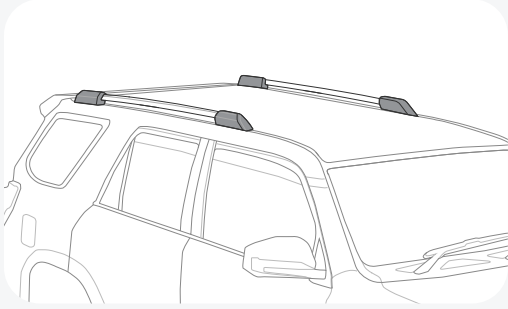

Proceed Here **Steps 1 - 4**

BARE ROOF

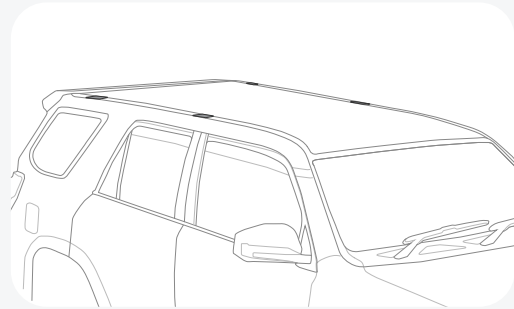

Skip to **Steps 5 - 7**

**1** Remove all end caps.

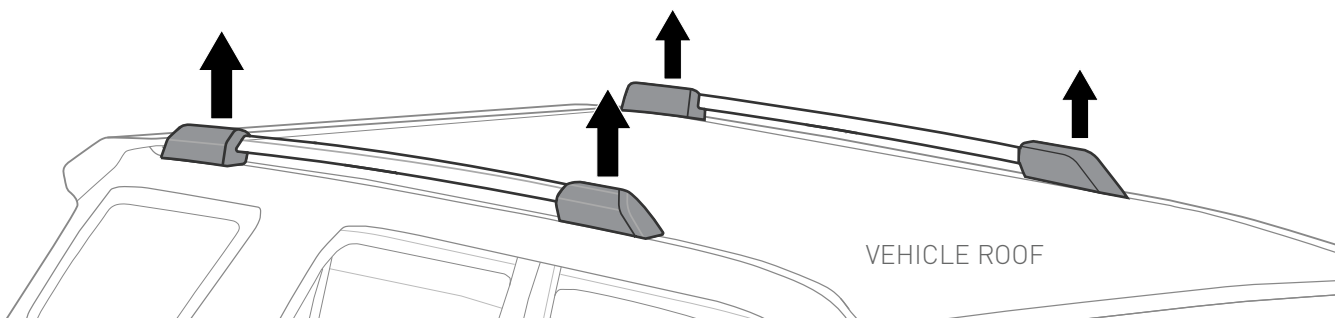

**1a** These are the internal clip locations and dimensions of the rear cover.

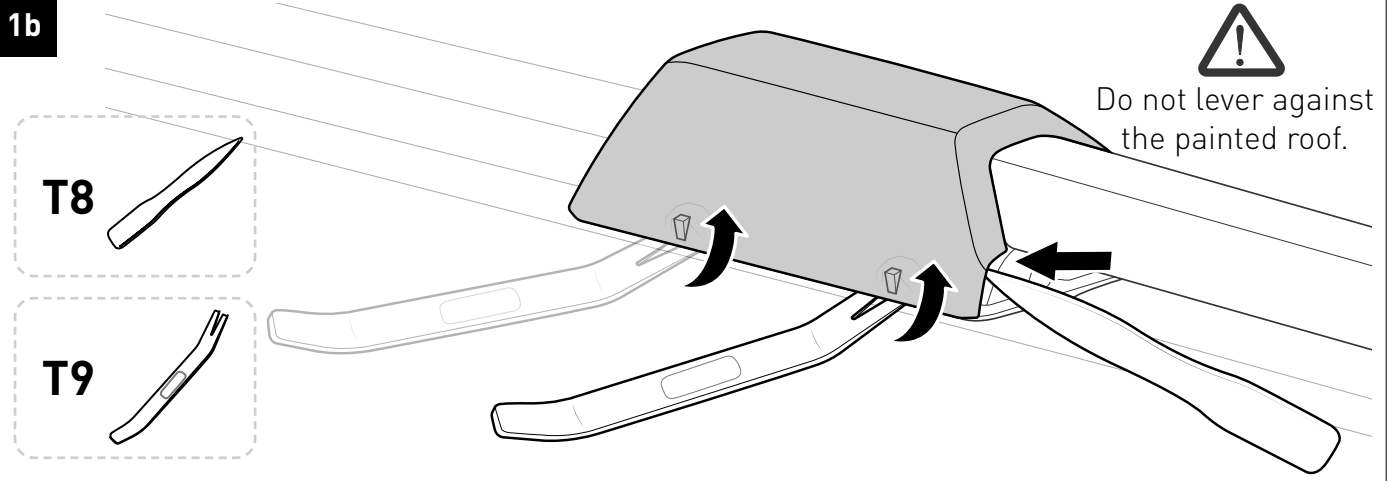
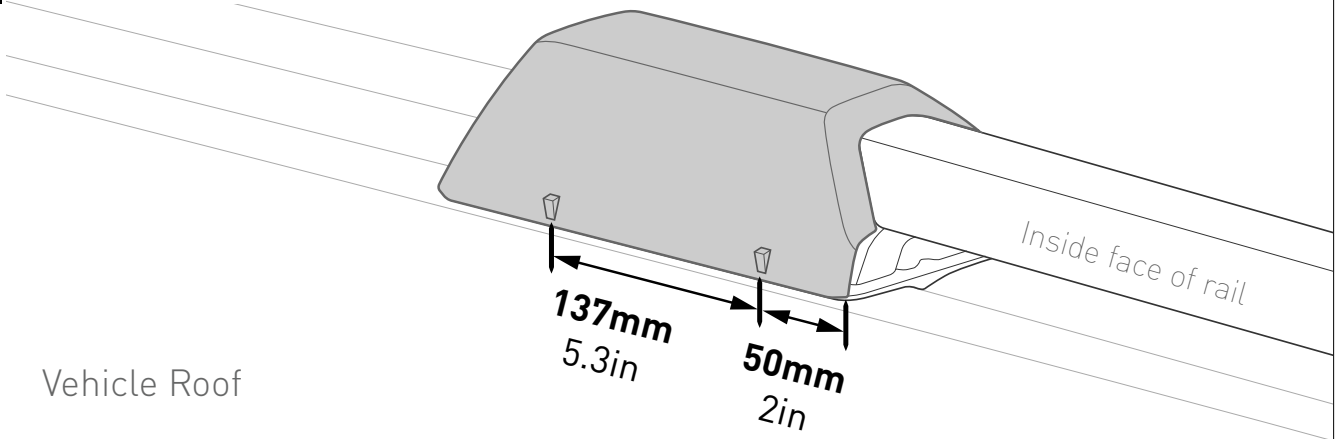

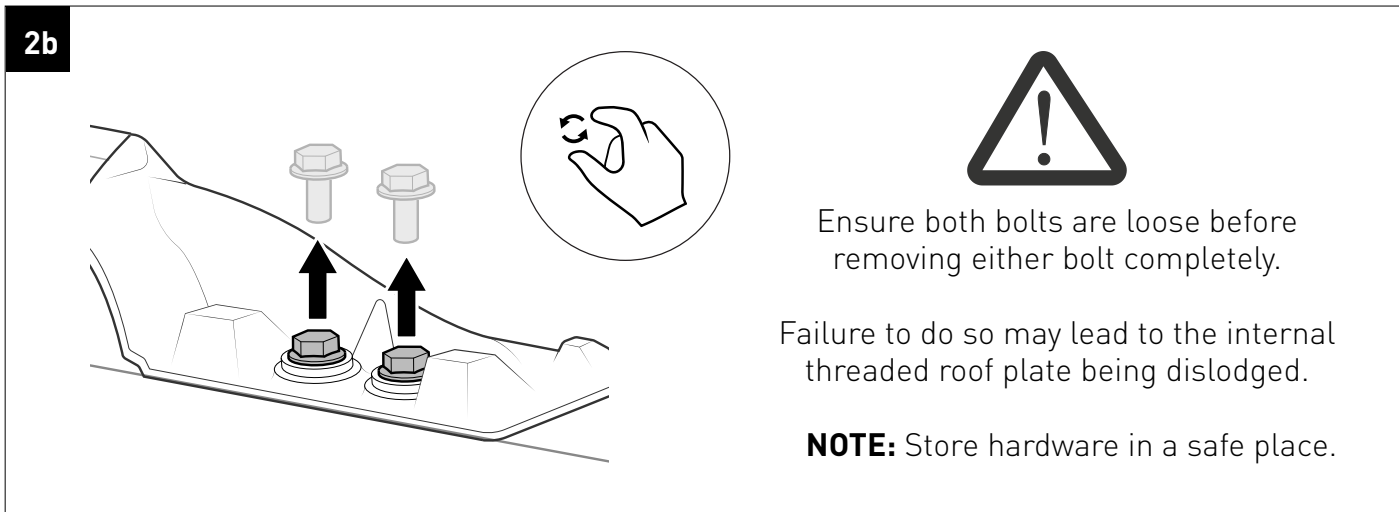
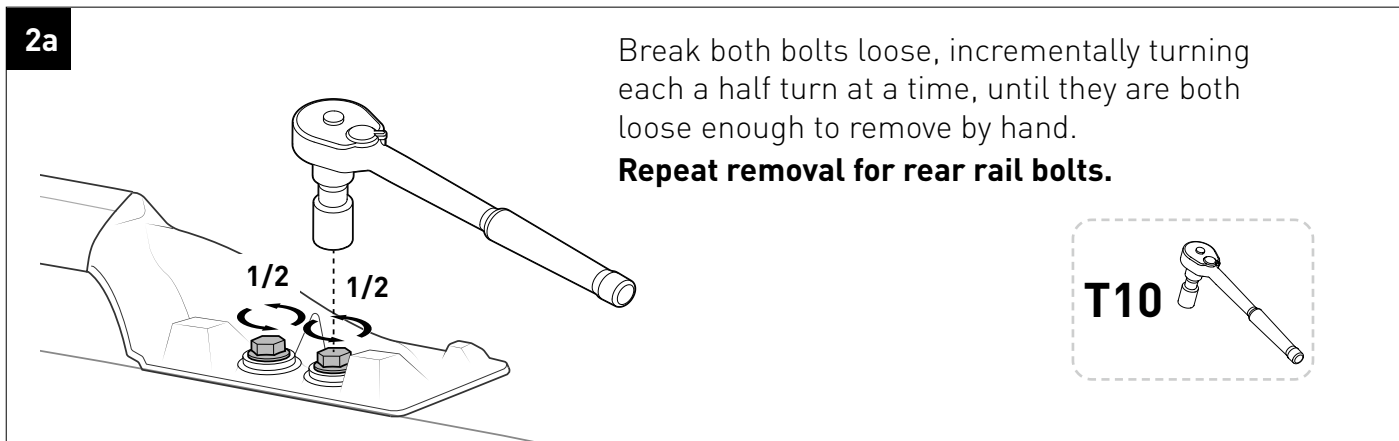
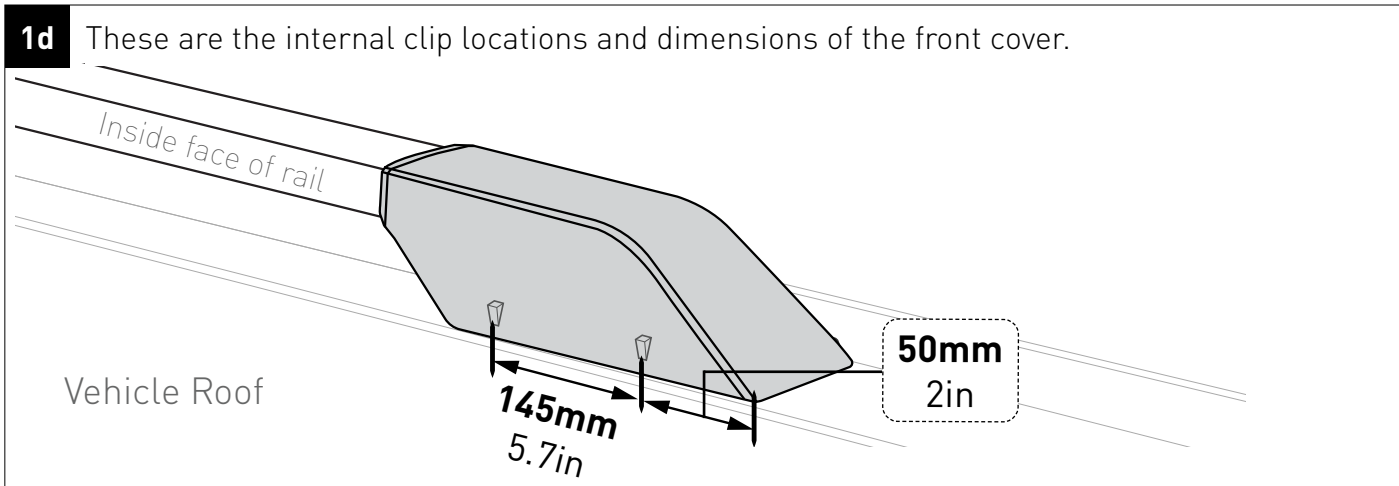
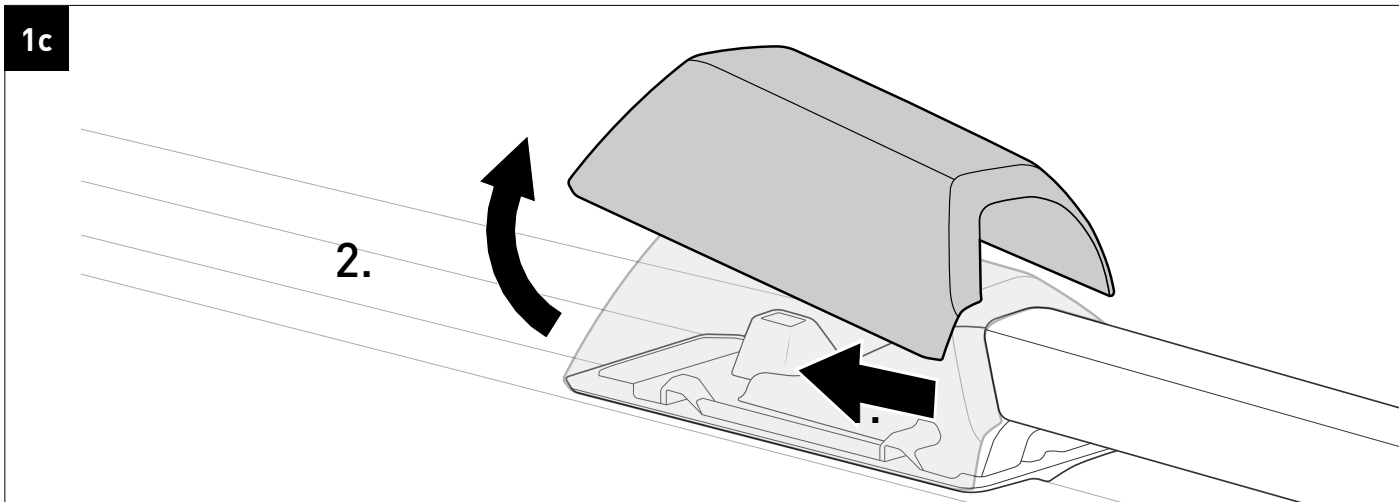

**3** Remove rails by lifting vertically.

**NOTE:** Store in a safe place.

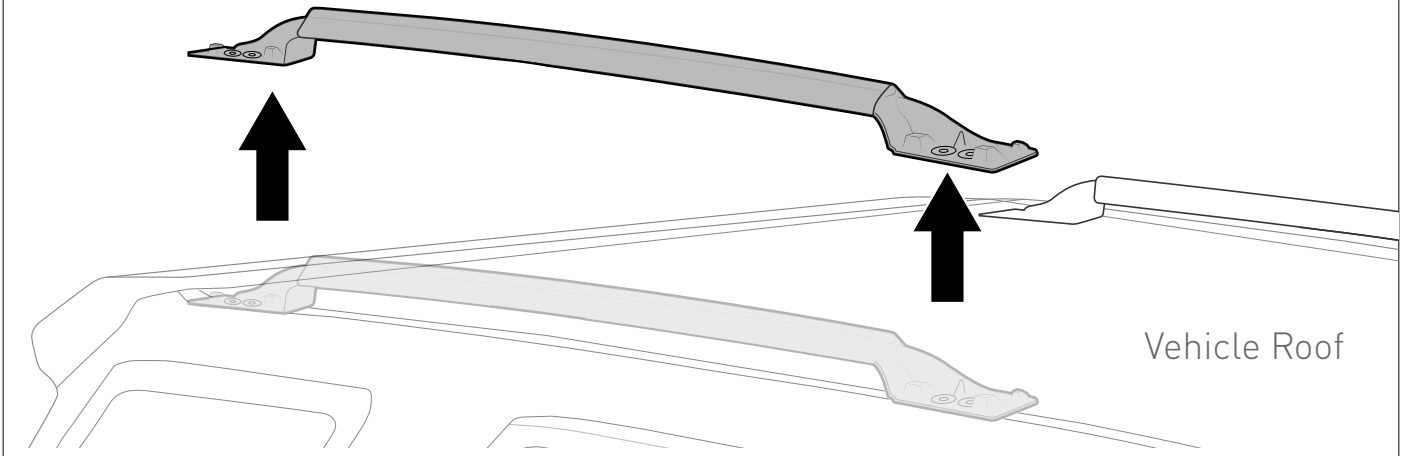

**Raised Rail** Removal Complete. **Skip to step 8**

**4** Remove mounting point covers (two per side).

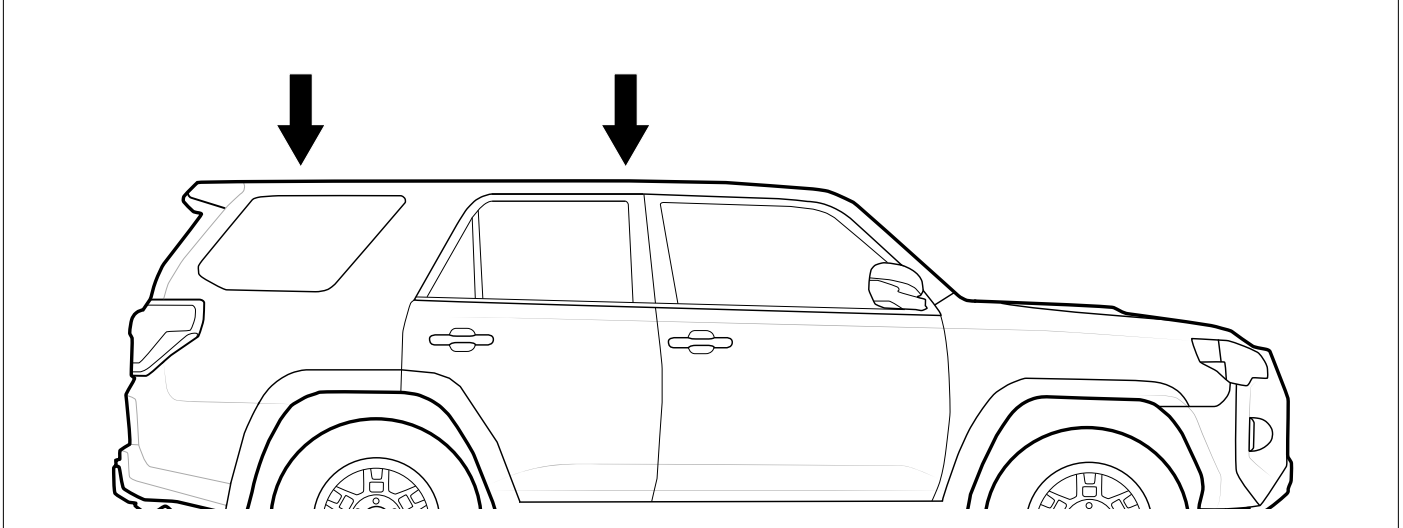

**4a** Lift end while pushing in the direction of the arrow.

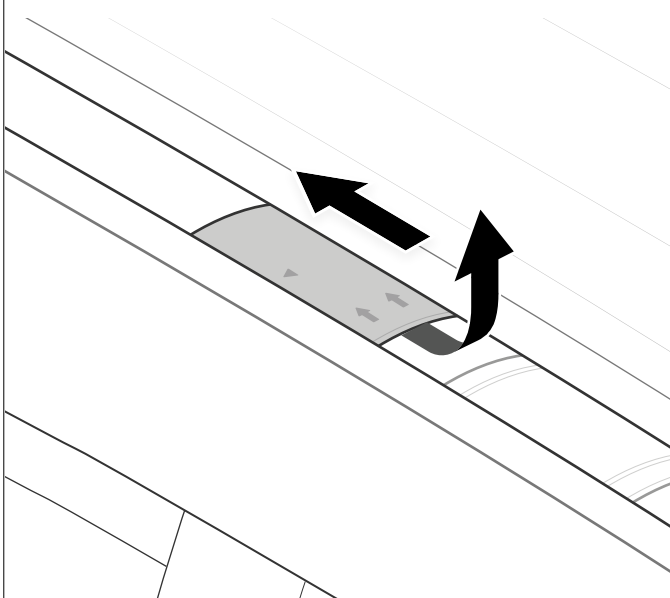

**4b** **NOTE:** Store covers in a safe place.

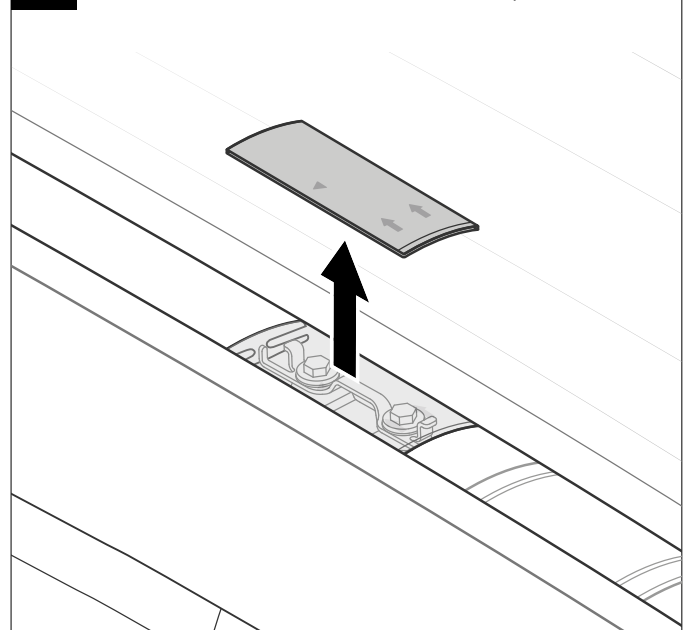



**5a** Break both bolts loose, incrementally turning each a half turn at a time, until they are both loose enough to remove by hand.

Remove factory bolts and hooks from selected mounting points.

**NOTE:** Store hooks and hardware in a safe place.

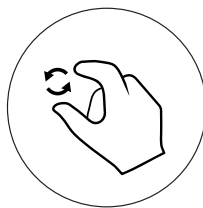
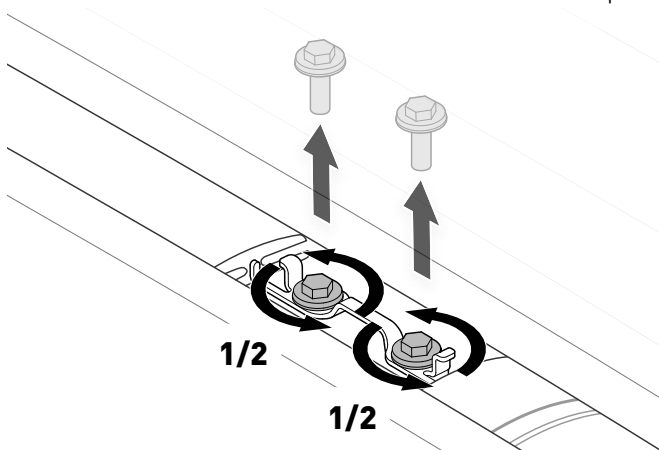

Ensure both bolts are loose before removing either bolt completely.

Failure to do so may lead to the internal threaded roof plate being dislodged.

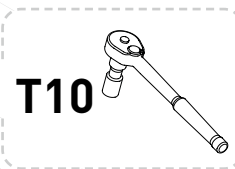

**5b**

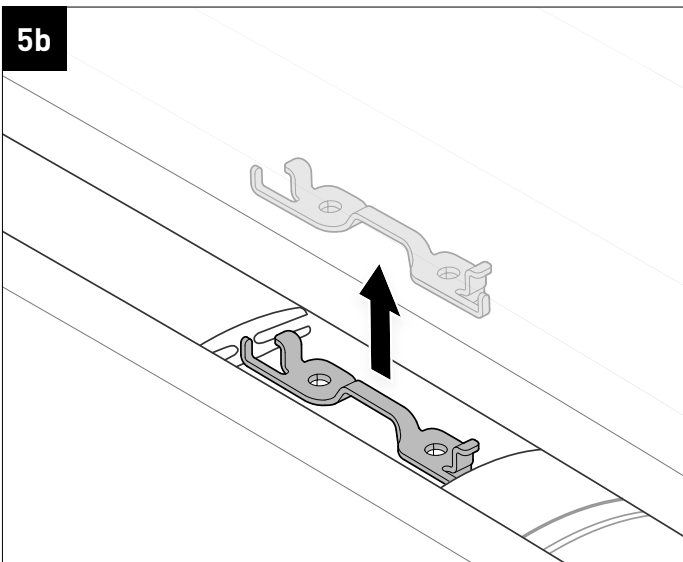

**5c**

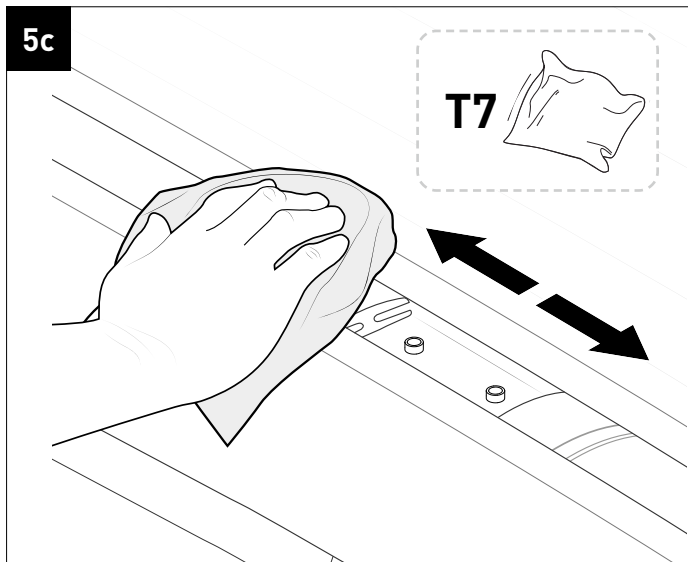

**Bare Roof Removal Complete.**

**P2** **6a** Use tapping screws **K** to remove any threadlock buildup from the existing thread.

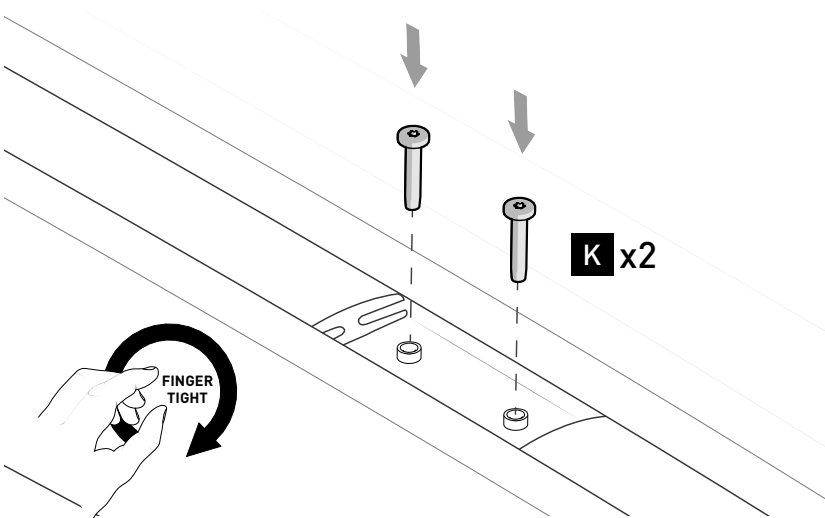

Operation should always be carried out with both screws engaged so that the internal roof plate is not dislodged.

Failure to do so may lead to the internal threaded roof plate being dislodged.

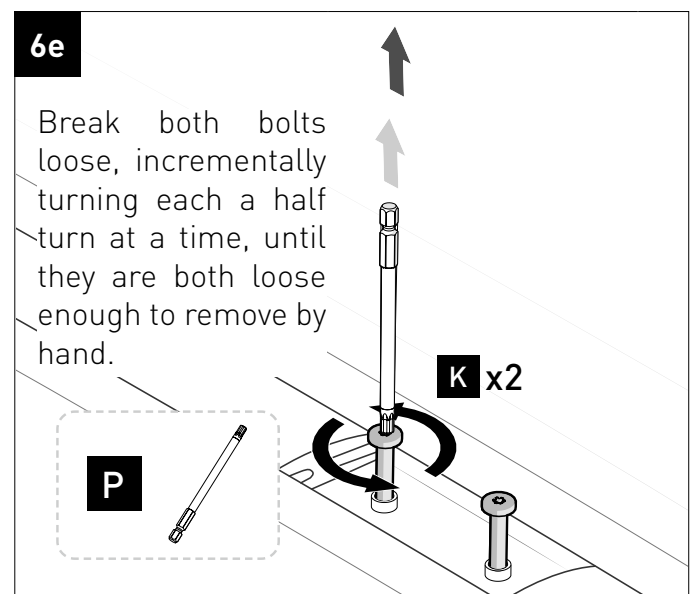
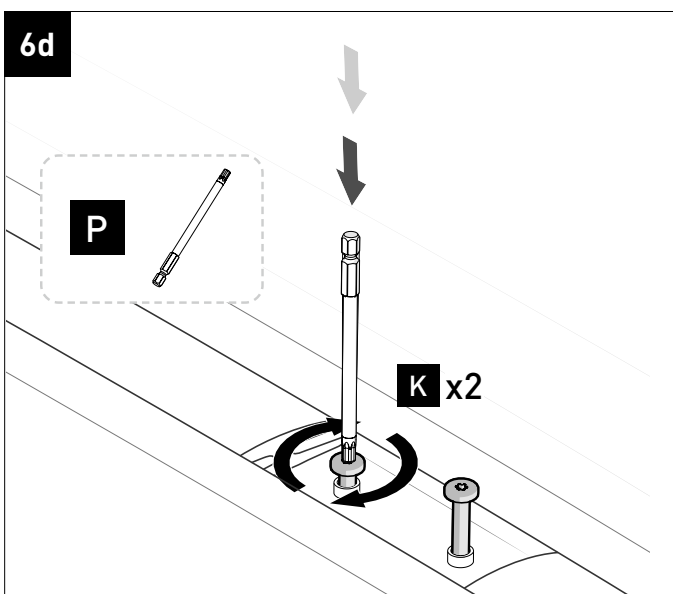
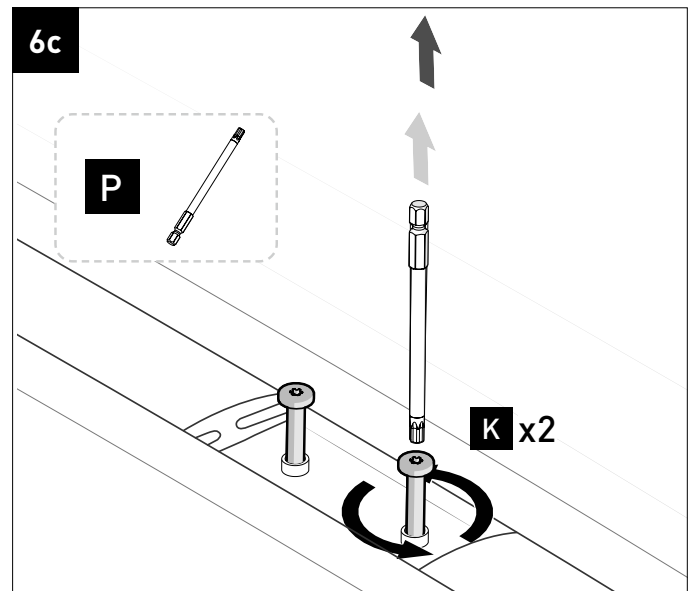
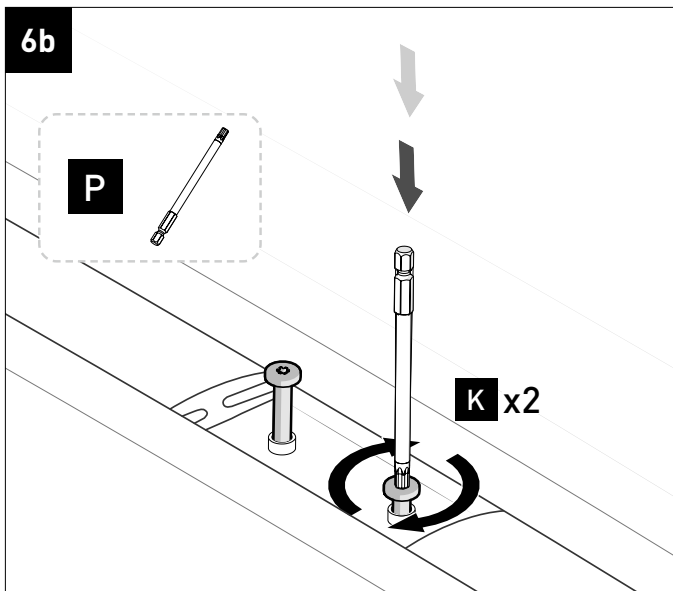

Repeat steps **6a** to **6e** for all 6 mounting points.

- 7** Assemble mounting blocks (3 per side) with supplied flanged bolts. Insert both bolts simultaneously and gently into the internal roof plate and finger tighten.



Ensure both bolts are inserted by hand before using **T6** to tighten.

Failure to do so may lead to the internal threaded roof plate being dislodged.

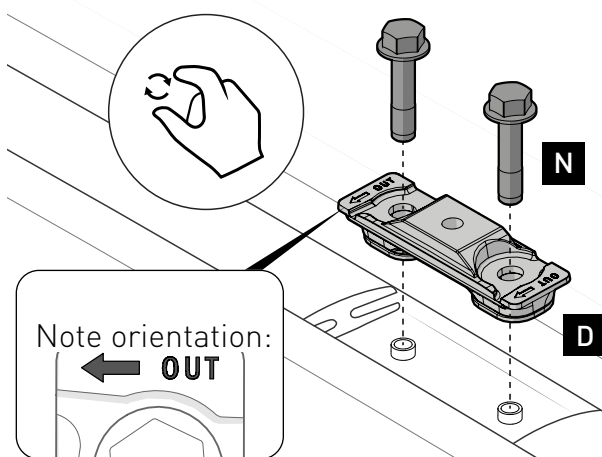

8

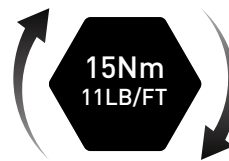
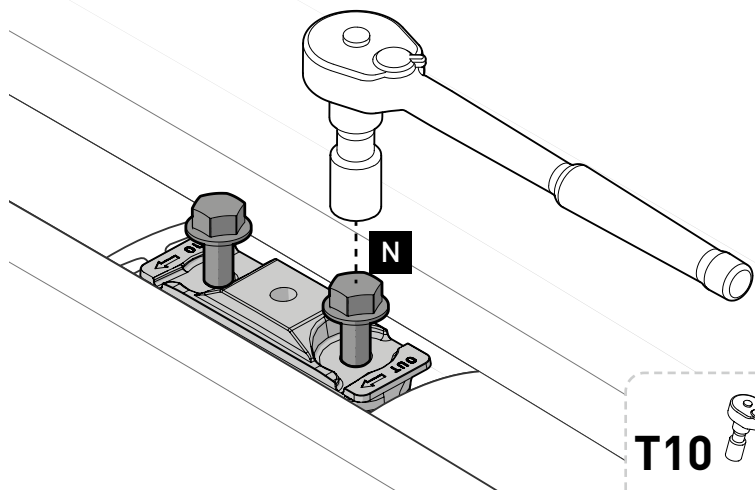

Once both bolts are threaded into the internal roof plate, use **T10** to tighten.

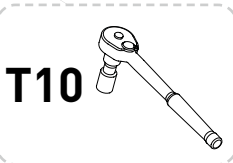

**9a** Mark righthand side ditch trim. Refer to step **9c** for **X** value.

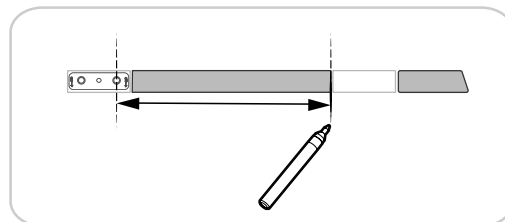
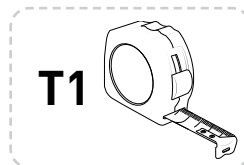
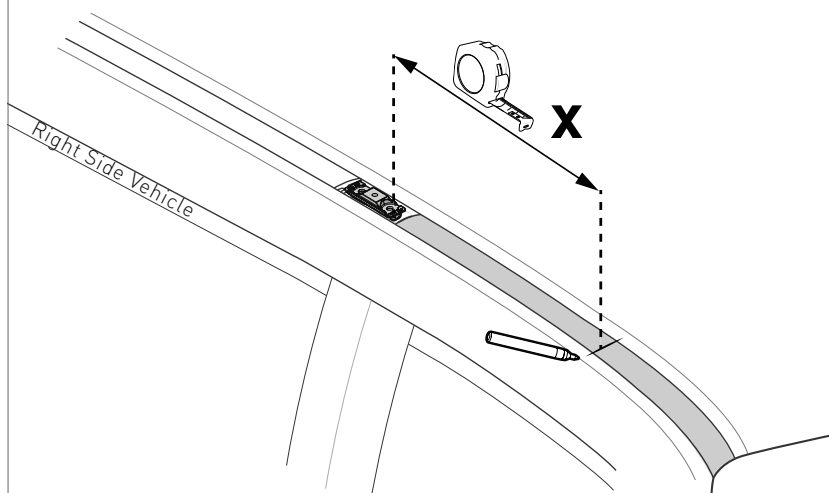

**9b** Refer to step **9c** for **y** value.

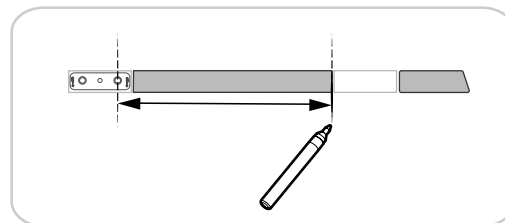
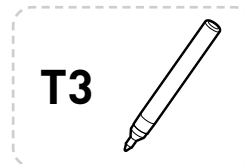
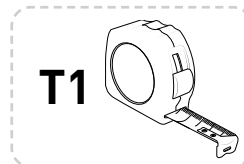
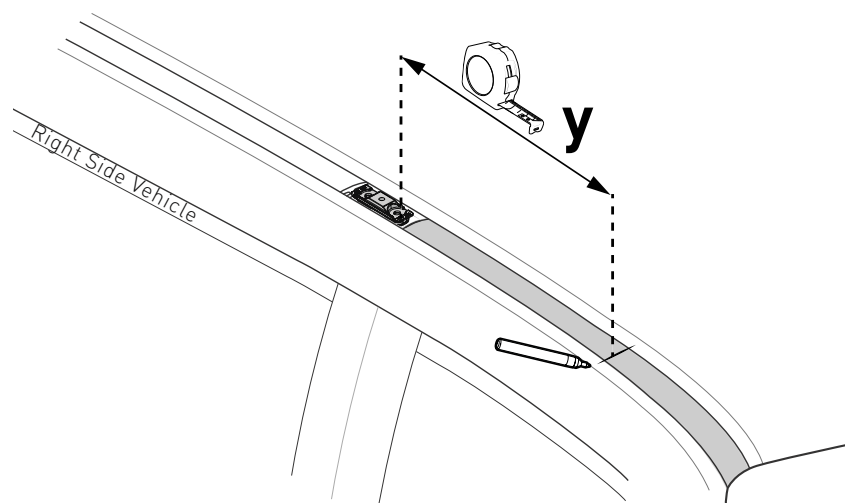

9c

**NOTE**

Measure from the centre of the front hole in the cast block.

**T1**

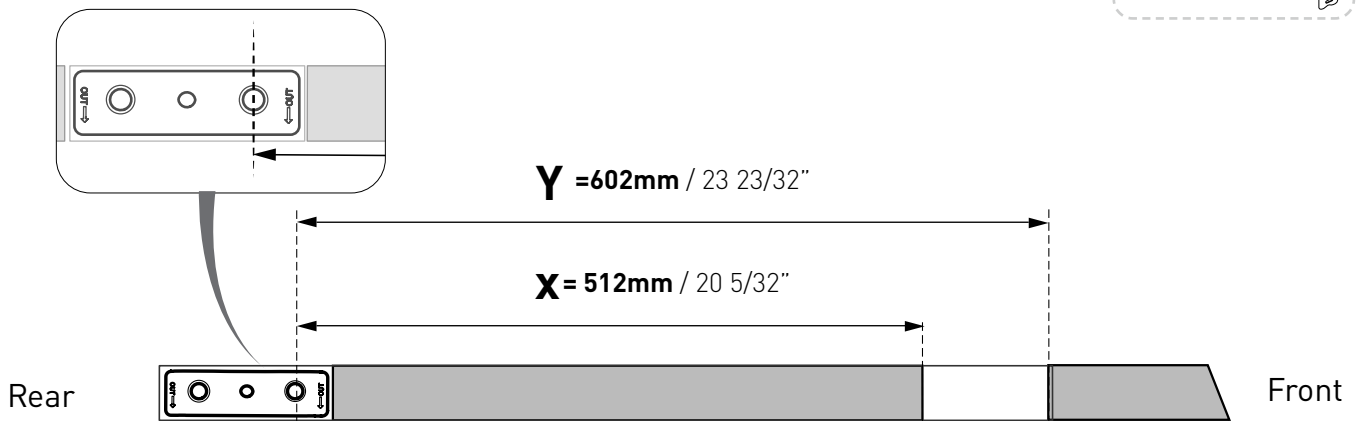
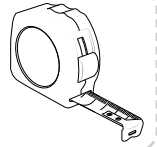

10a

Partially remove the RH side rubber ditch trim.

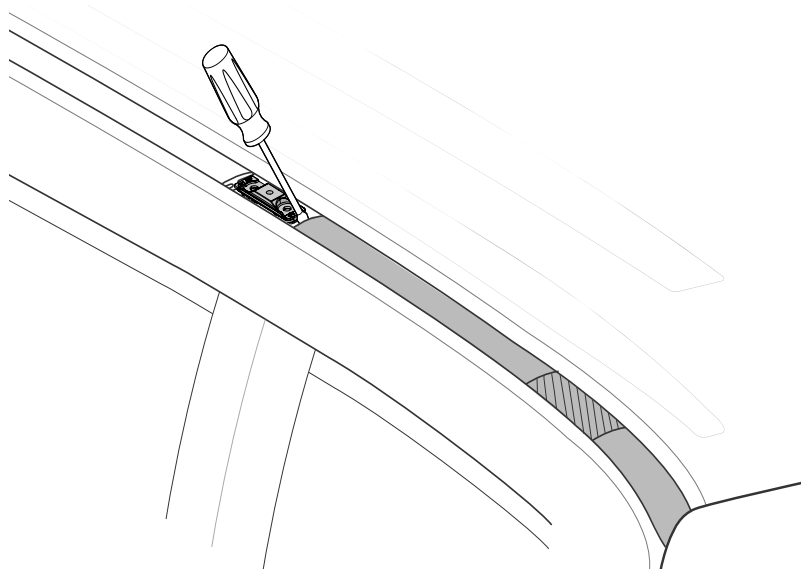

**T4**

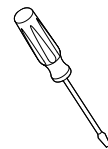

or

**T9**

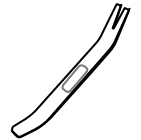

Do not lever against the painted roof.

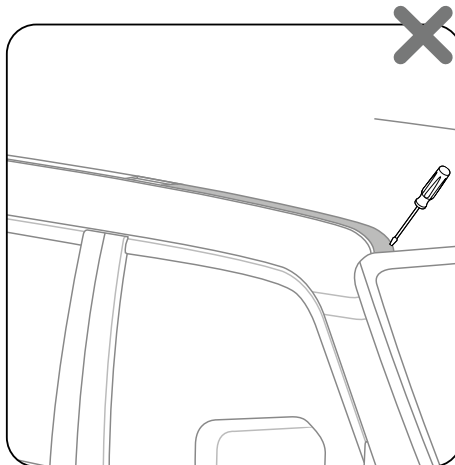
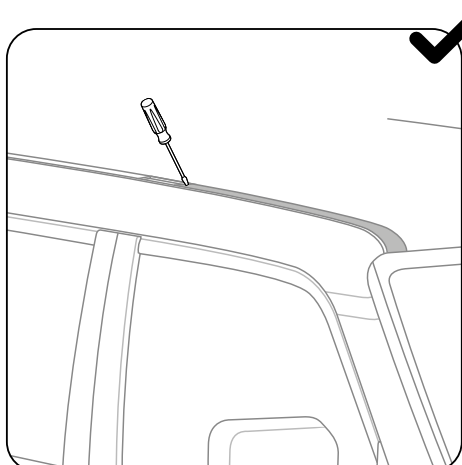

**NOTE**

Avoid completely removing the rubber trim to avoid damaging seal at the end of the front windscreen.

10b

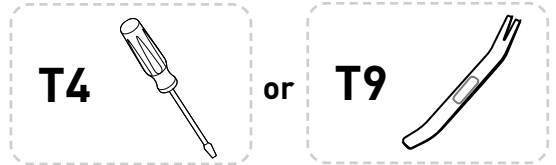
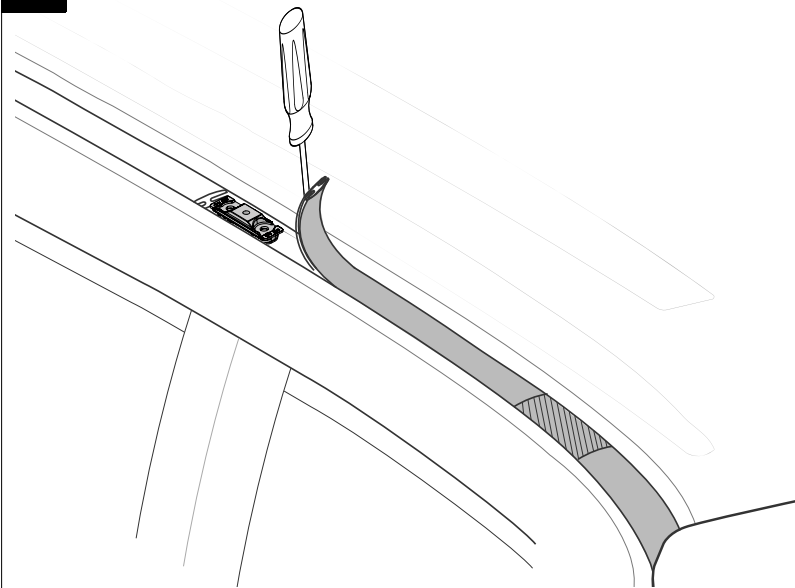

Do not lever against the painted roof.

11a

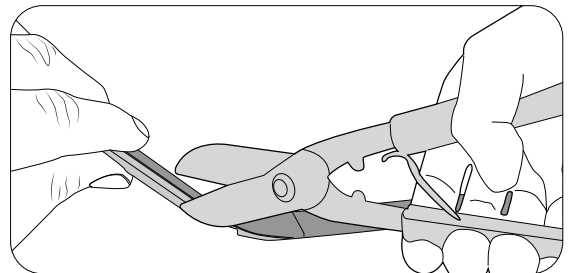
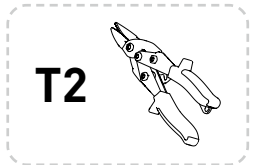
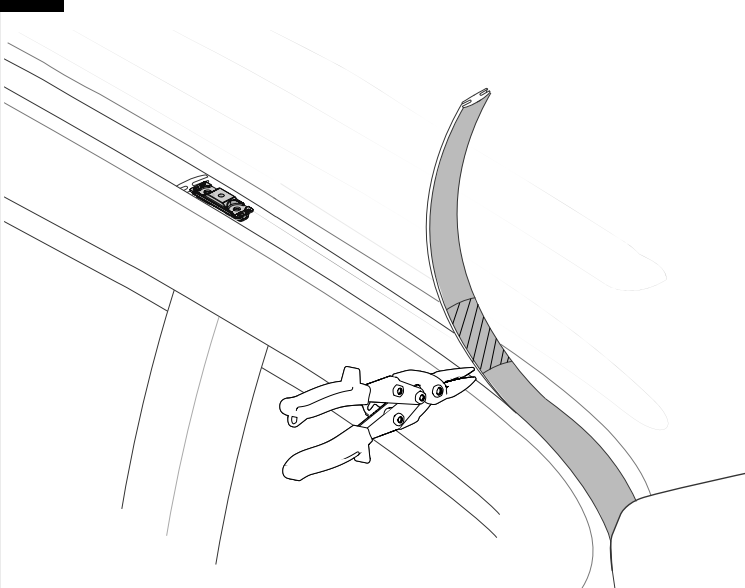

11b

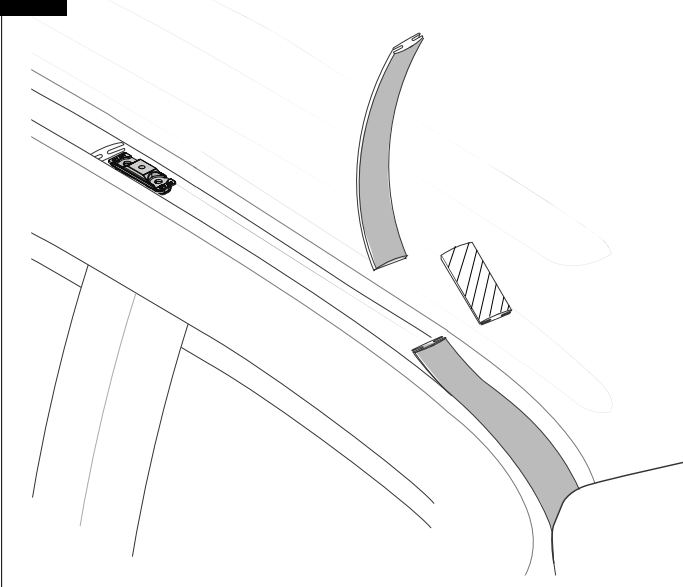

11c

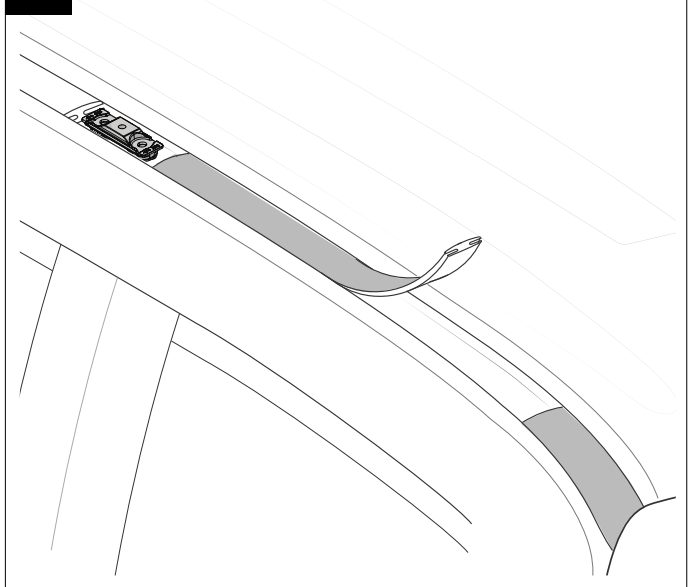

12

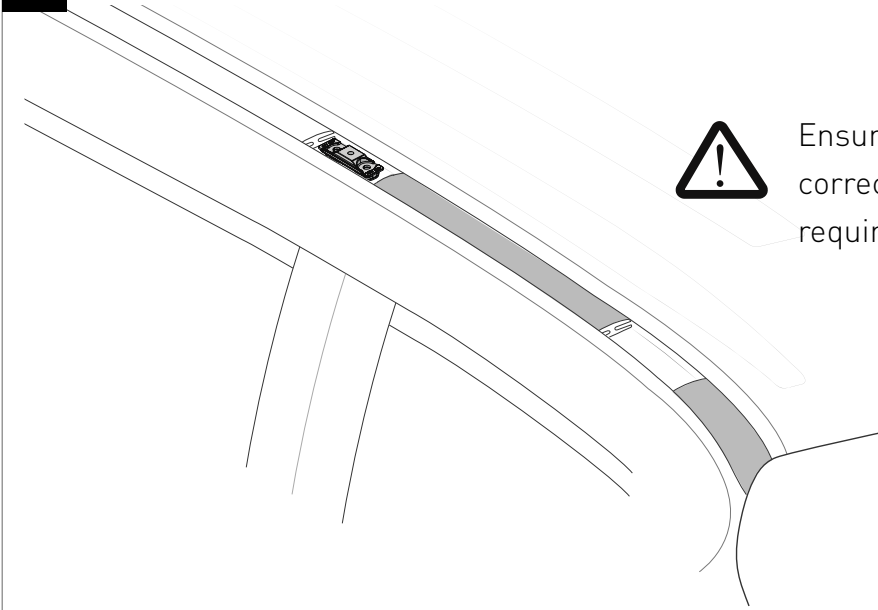

Ensure gutter trim is stuck back down correctly. Double sided tape may be required.

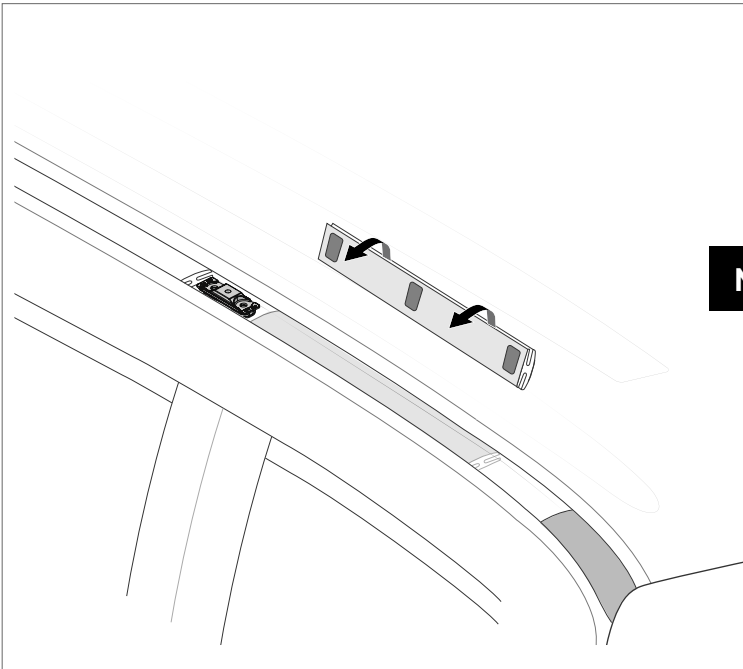
**NOTE**

If required to reattach the trim, use 3M tape or an equivalent adhesive.

**13** Repeat step **9** - **12** for **left** Ditch Rubbers.

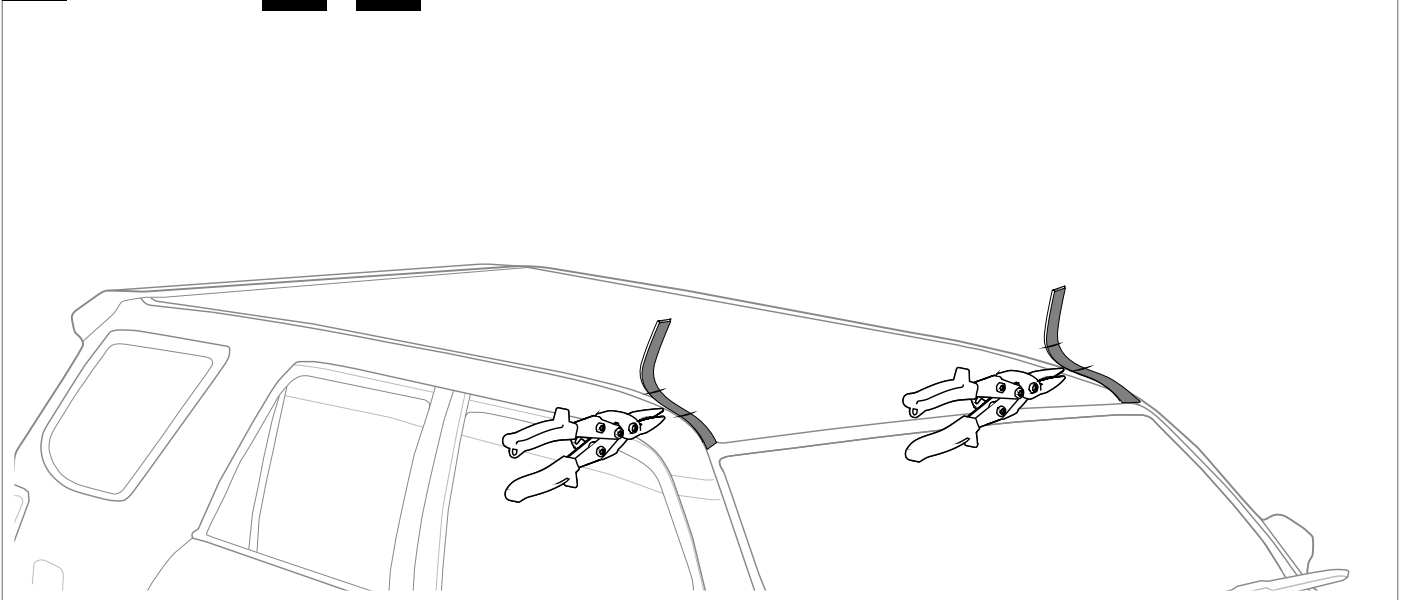

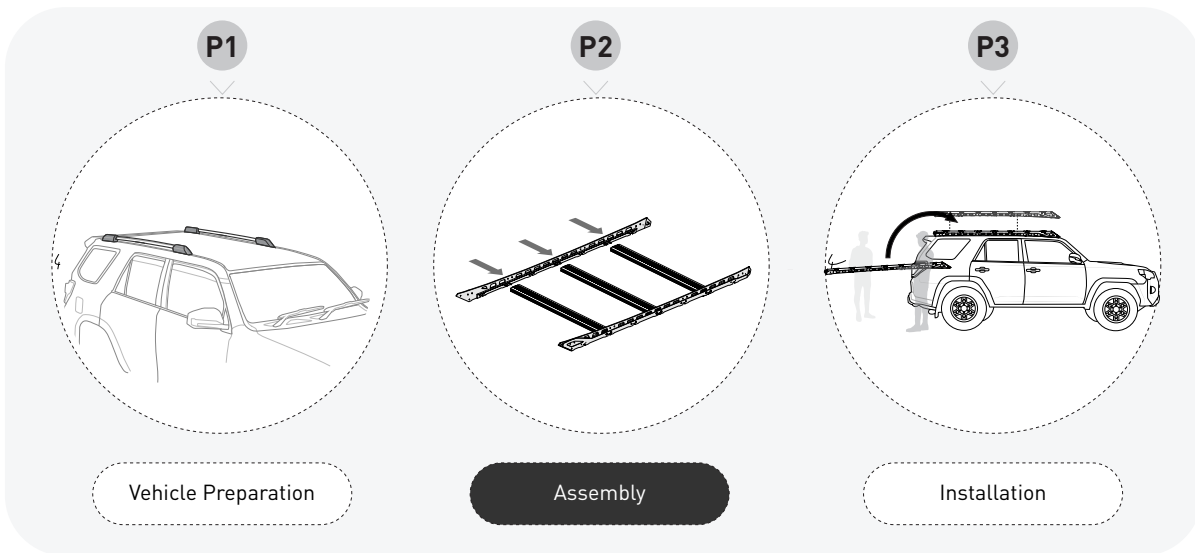

P2  
▼

14

**NOTE** The rear ends angle inward toward the center of the vehicle, indicating the left and right blades.

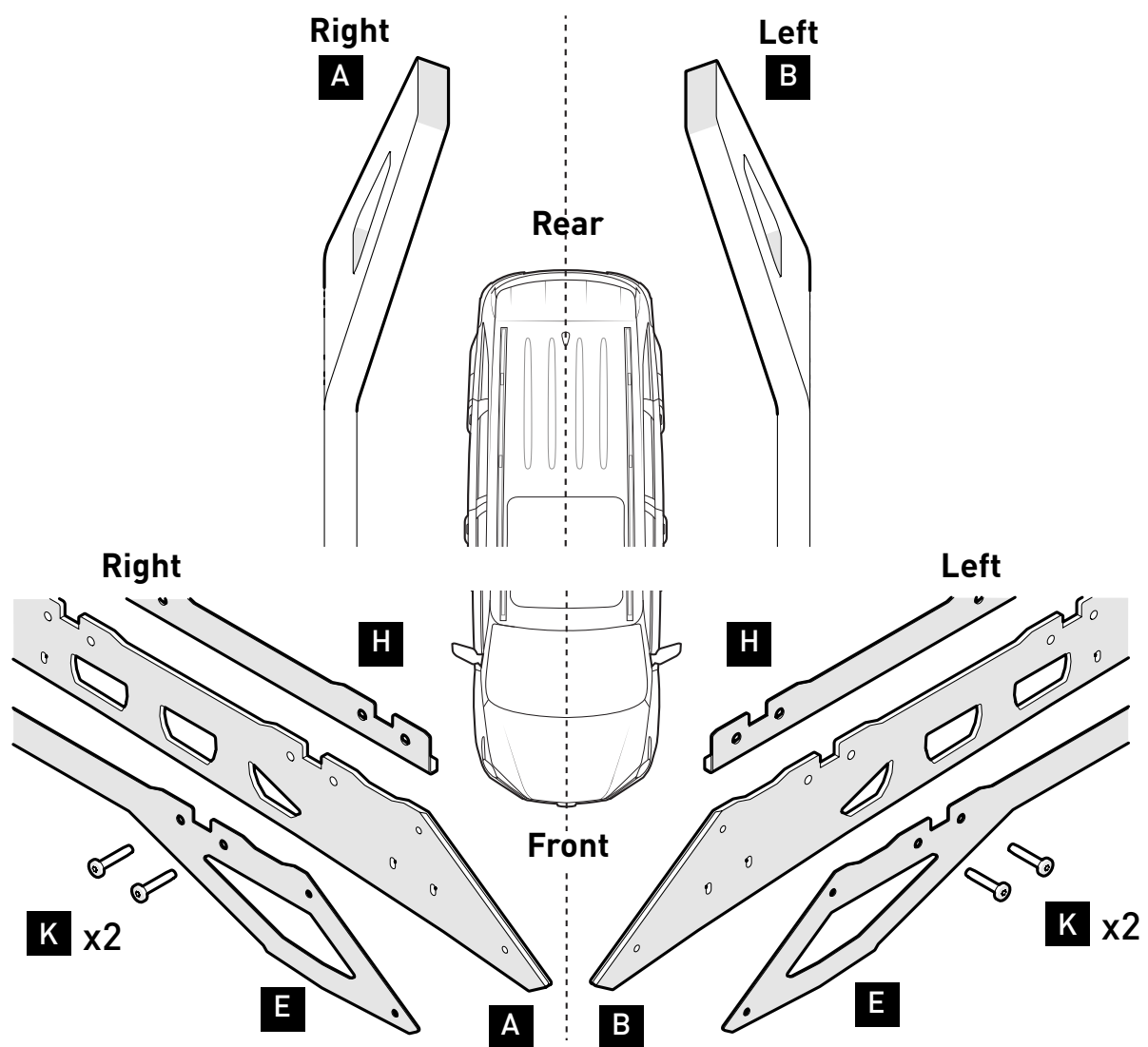

**15** Loosely assemble **2x bolts** at each of the **3 indicated locations** on **left side blade**.

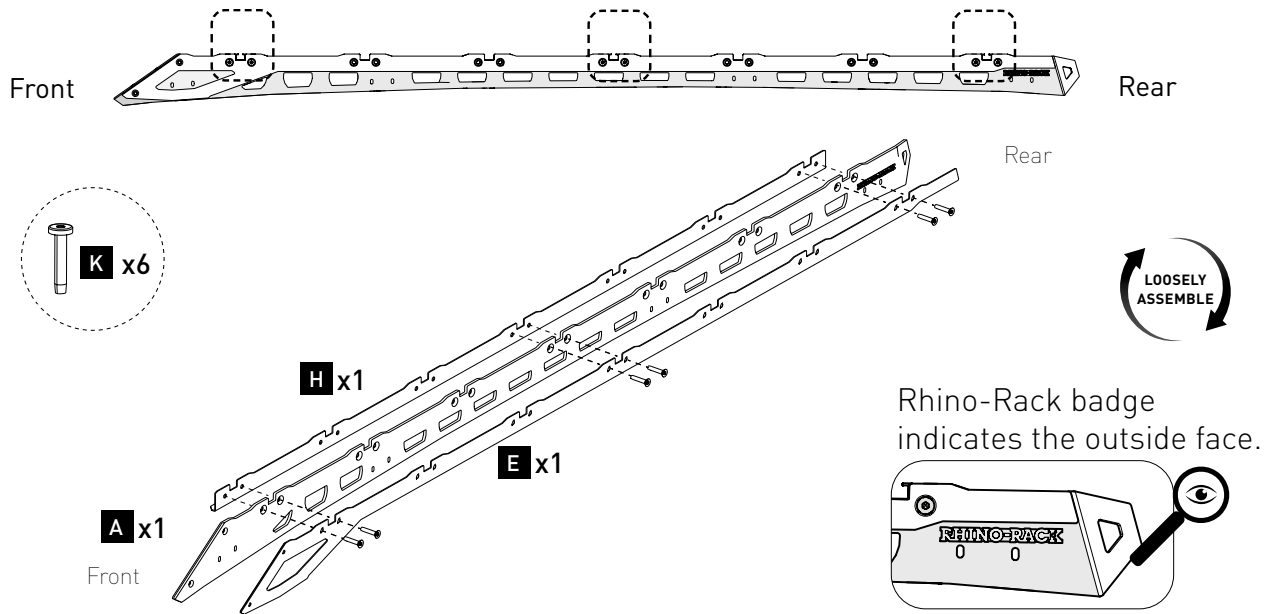

**16** Loosely assemble **2x bolts** at each of the **3 indicated locations** on **right side blade**.

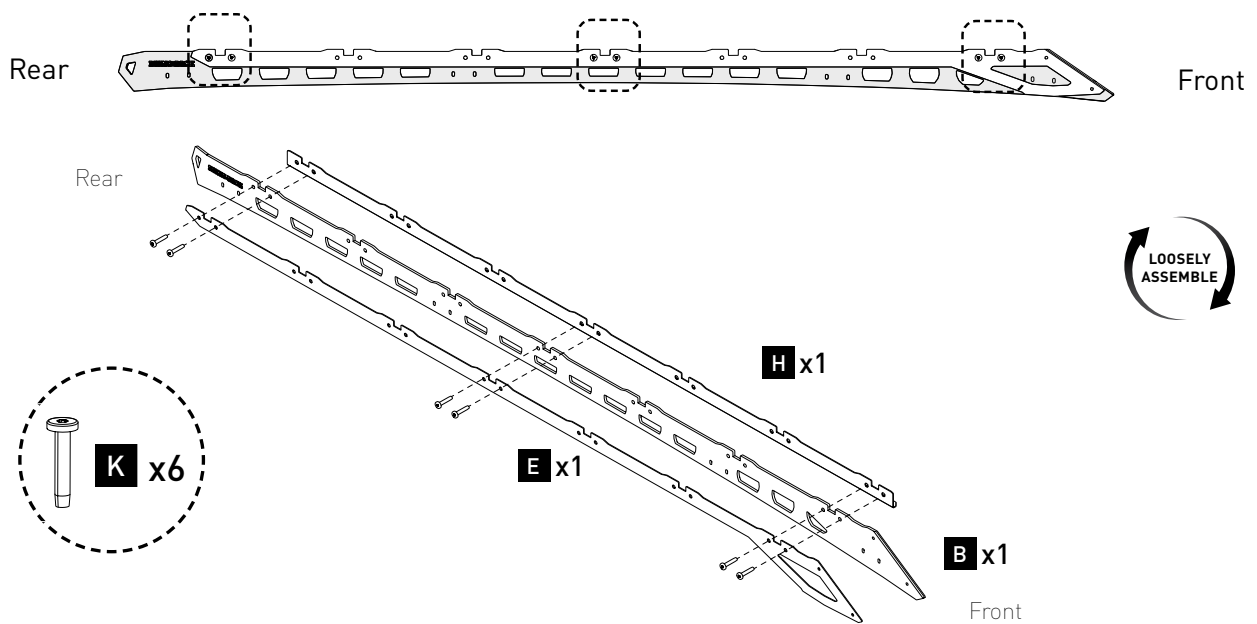

**17** Ensure that **H** is positioned correctly on both left & right blades.

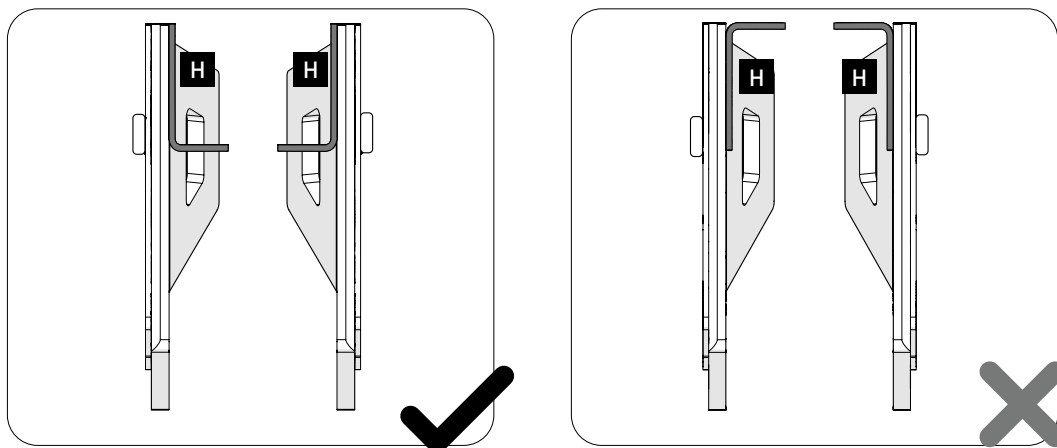



**18** Flip blade assemblies.

**NOTE**

Upside-down Rhino-Rack badge indicates correct orientation.

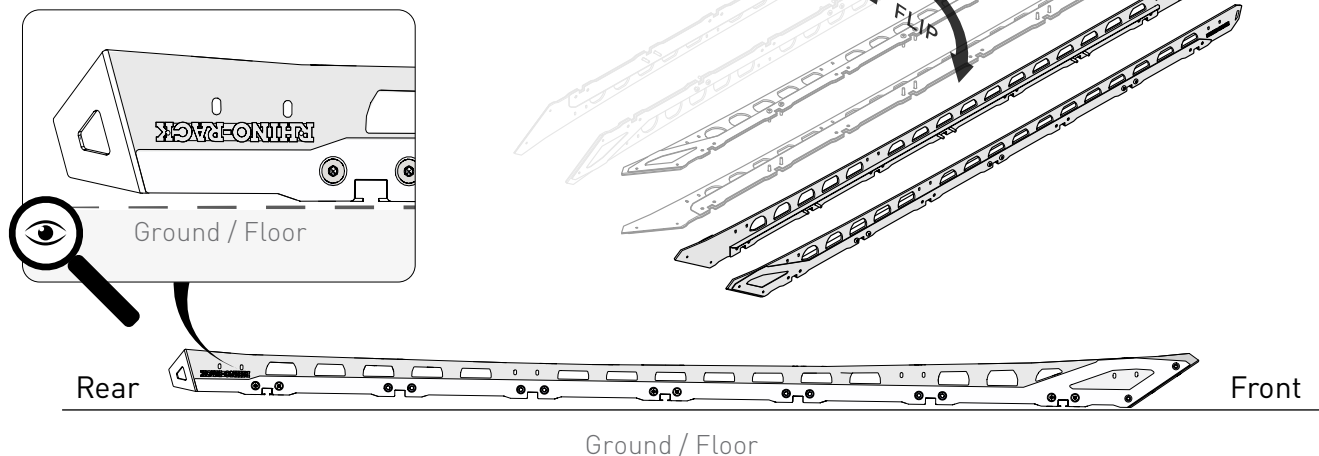

**19** Screw **3x** RDB120P bars to right hand blade assembly.

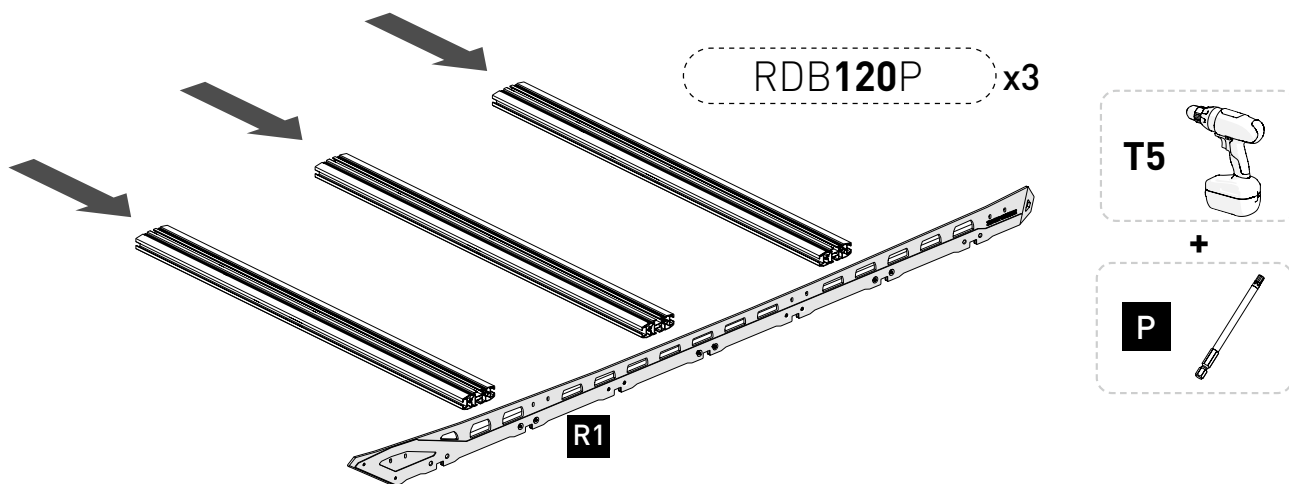

**NOTE** For easier handling, use **K** screws pre-tap **3x** RDB120P bars at both ends.

 Brace or clamp the bar during this step.

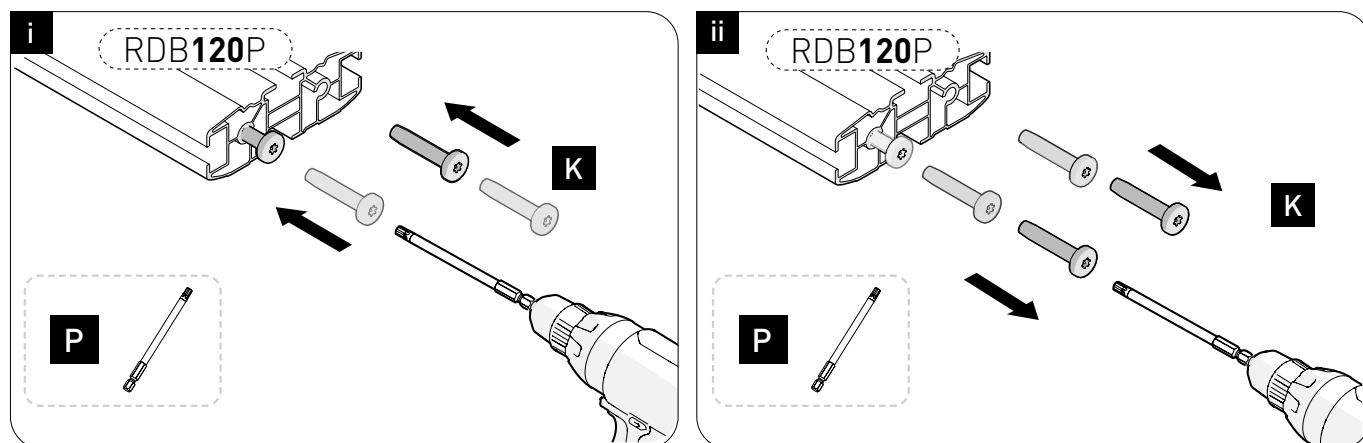

20

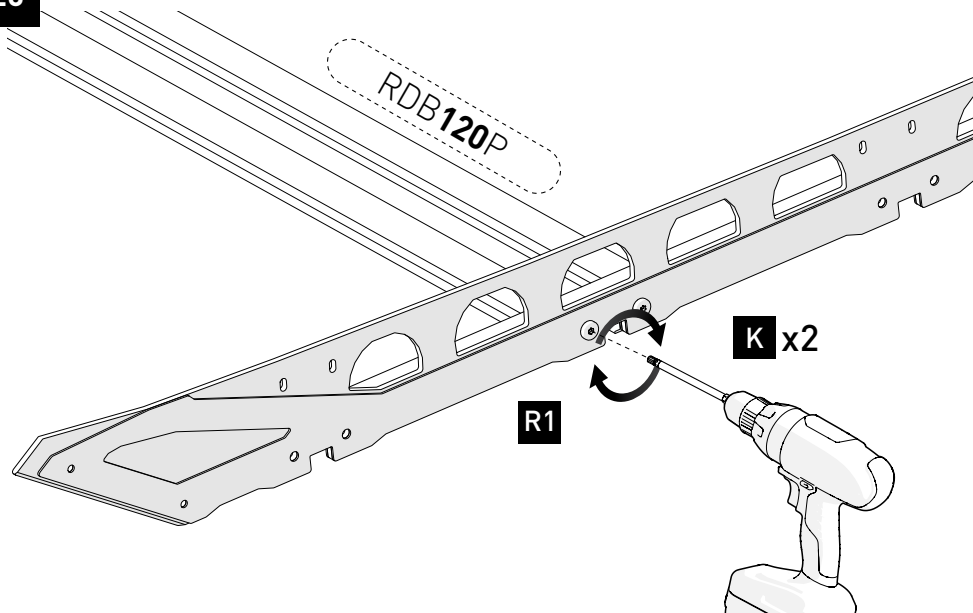

P

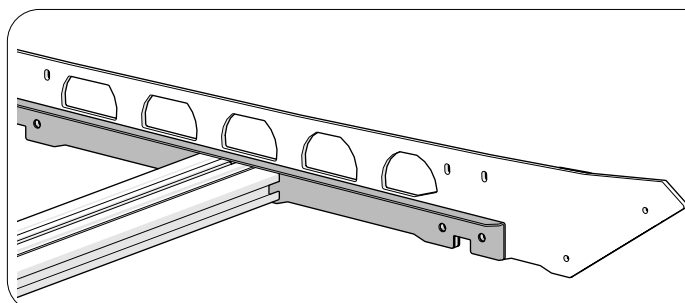
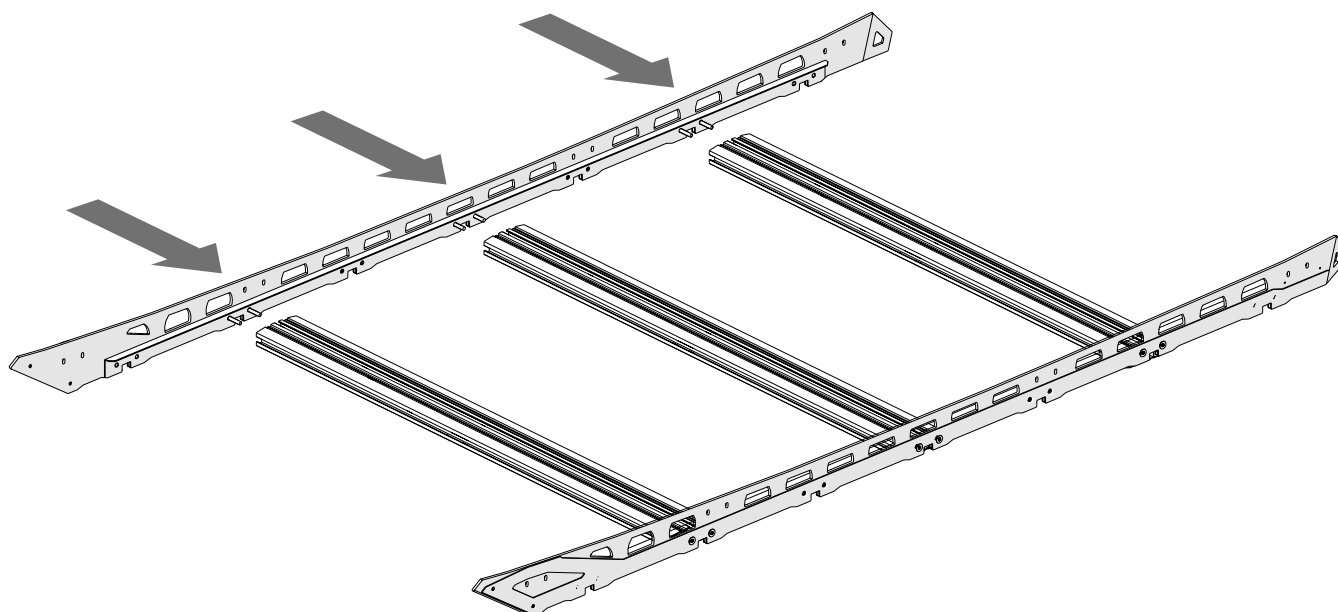
Tighten **K** to**NOTE**Ensure **RDB120P** Bars sit under **H x1**21 Repeat steps **19** & **20** with left hand blade assembly.

22

**NOTE**

Foot positions are indicated by notches located at the top edge of the foot.

The foot with **1 notch F** indicates **Front Placement**.

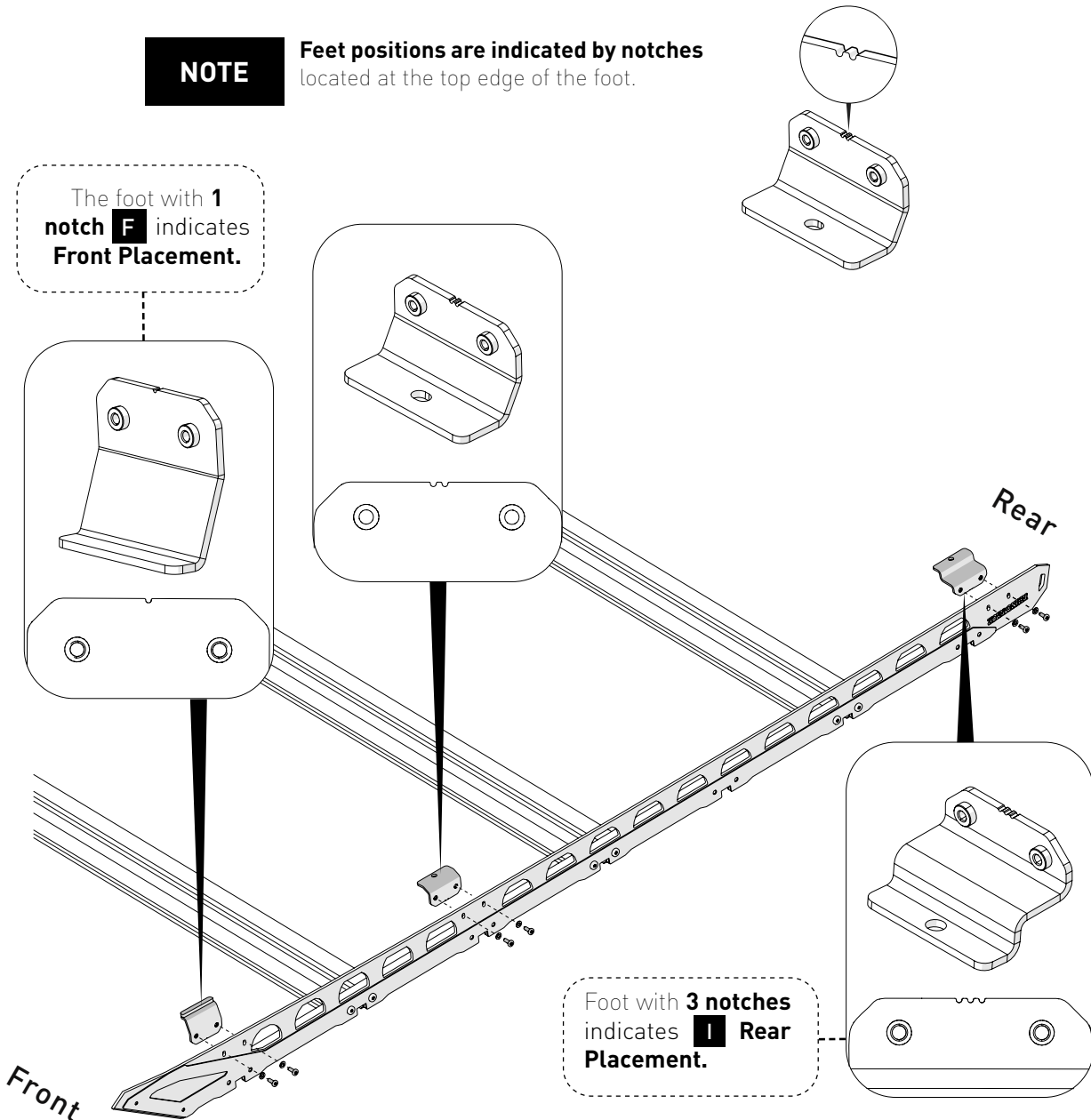

Foot with **3 notches** indicates **I Rear Placement**.

23

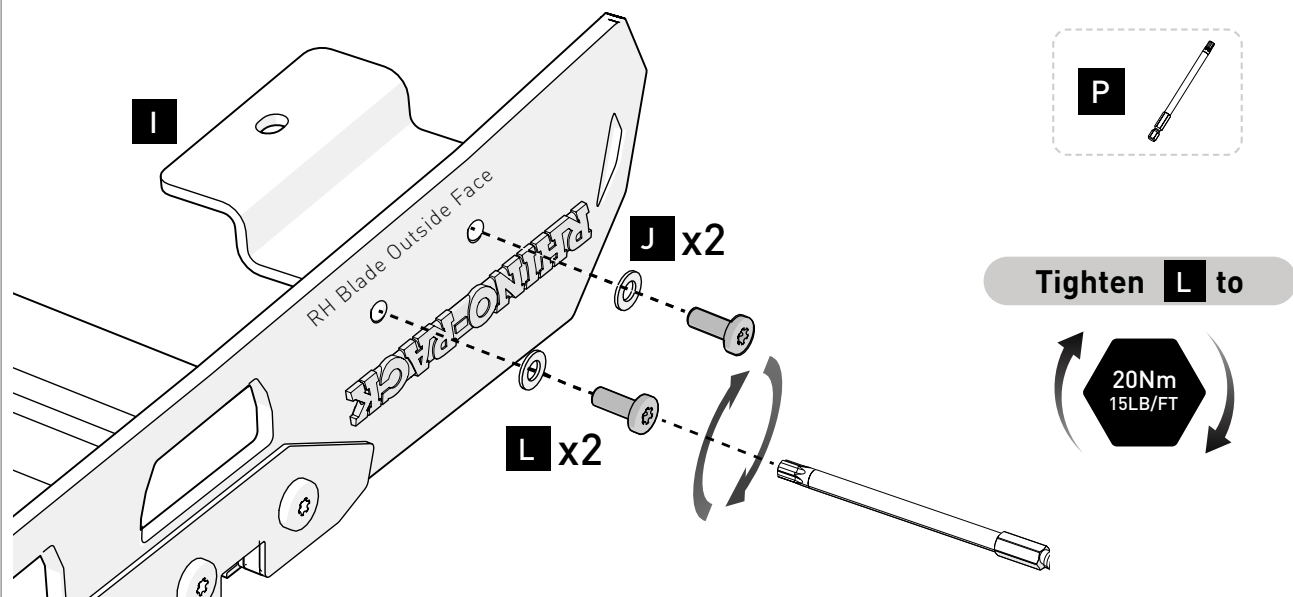

**24** Repeat step **23** for all remaining feet on both sides.

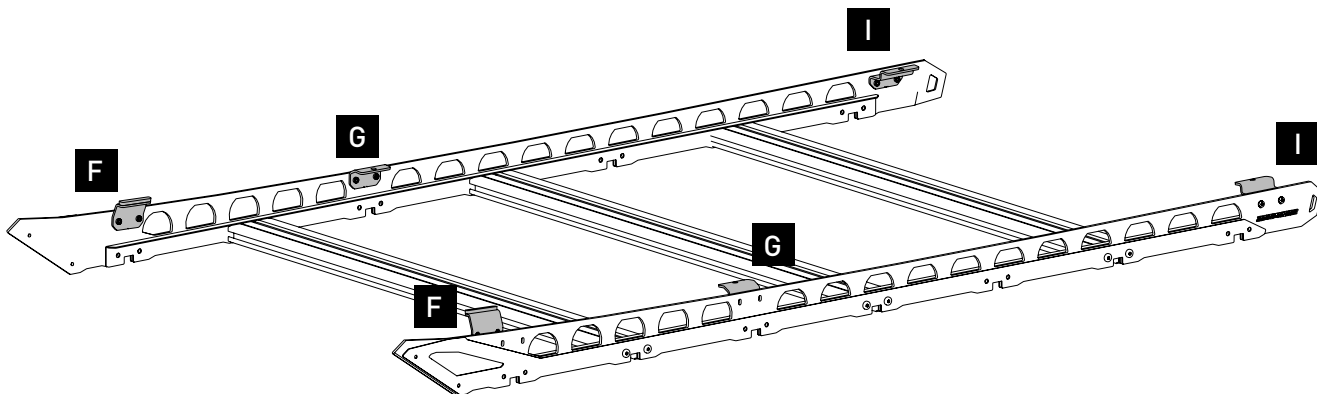

**24**

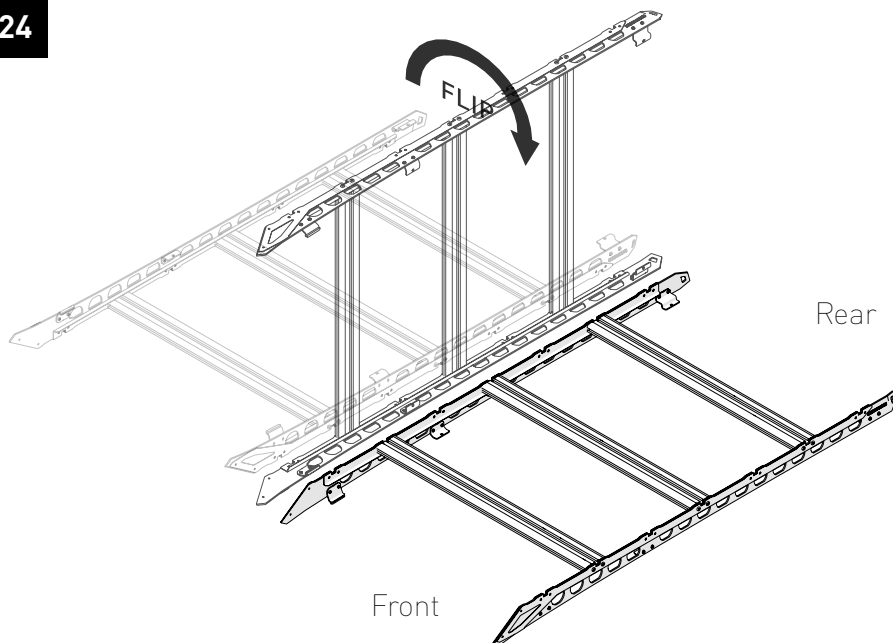

1 2  
TWO PEOPLE  
REQUIRED

**NOTE**

Upright Rhino-Rack badge indicates the correct orientation.

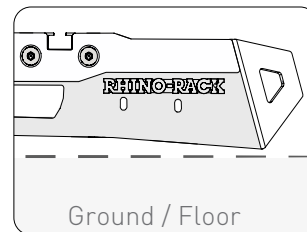

P1

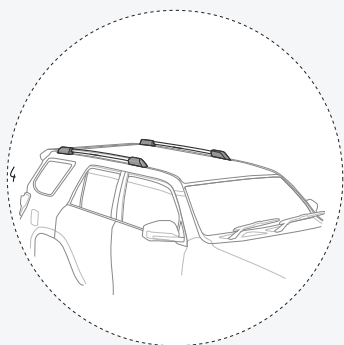

Vehicle Preparation

P2

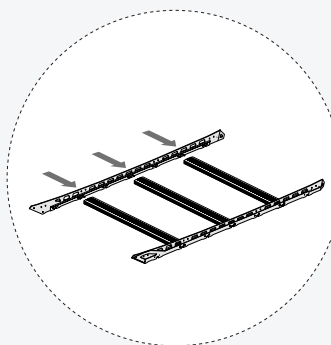

Assembly

P3

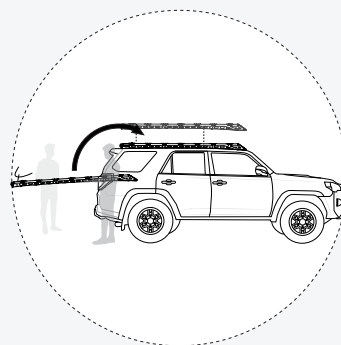

Installation

P3

**25** Lift Recon platform onto vehicle, Carefully placing feet on cast blocks installed in step **7** .

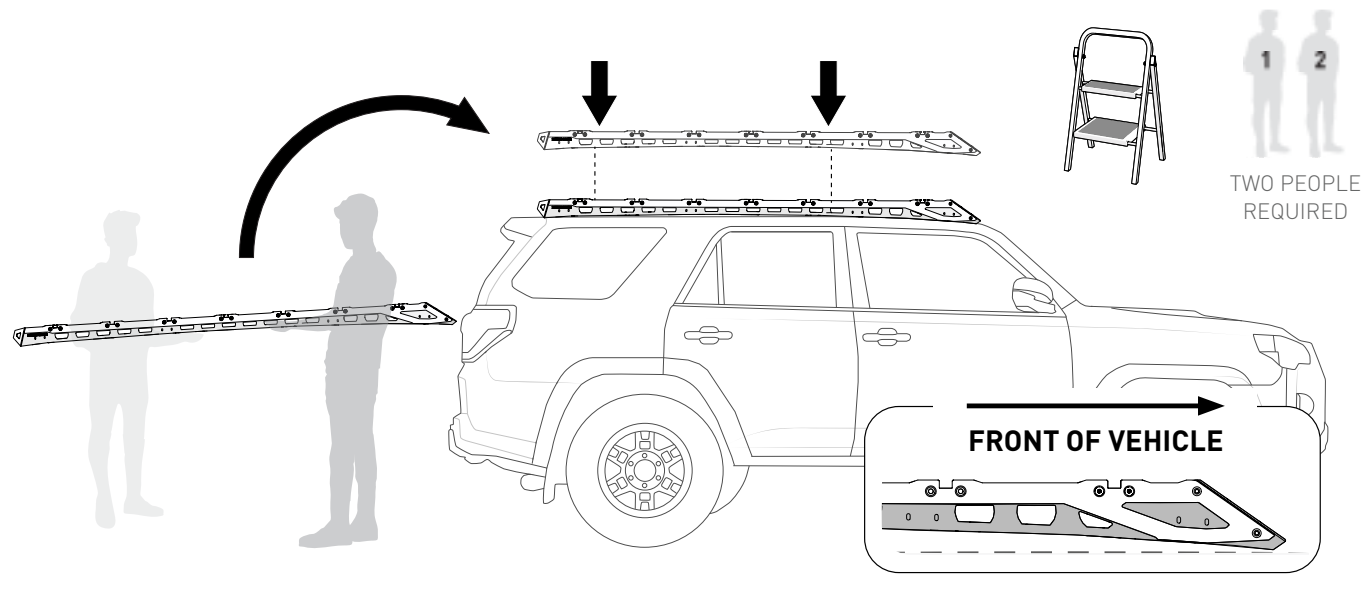

**26** Align holes in feet to holes in cast blocks.

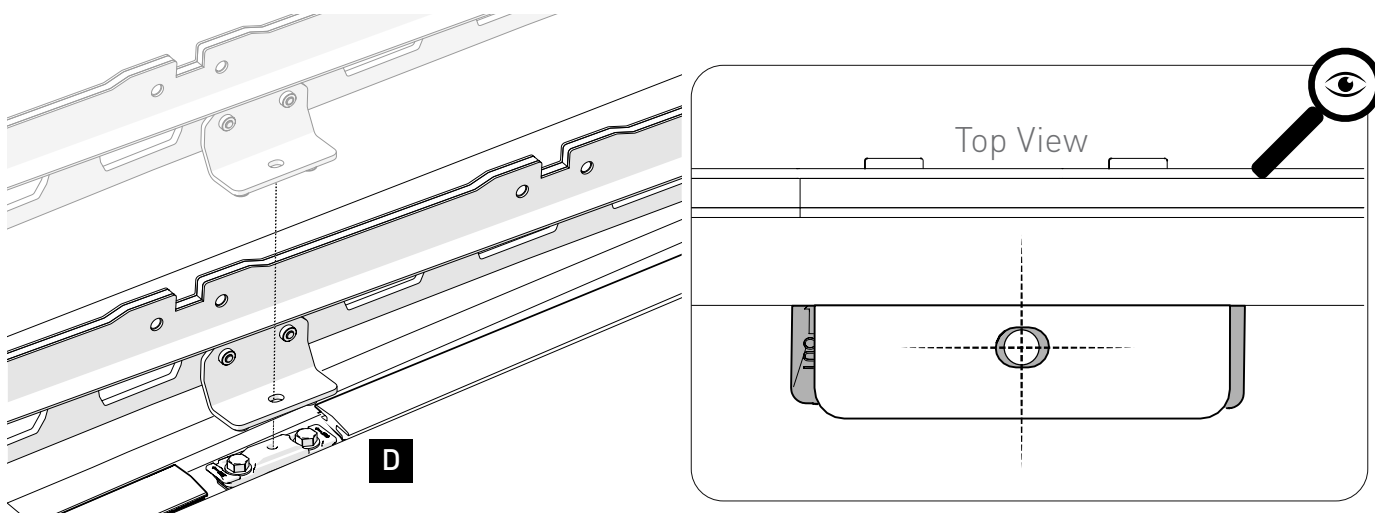

**27** Front foot sits in gutter as seen in steps **9** - **13** .

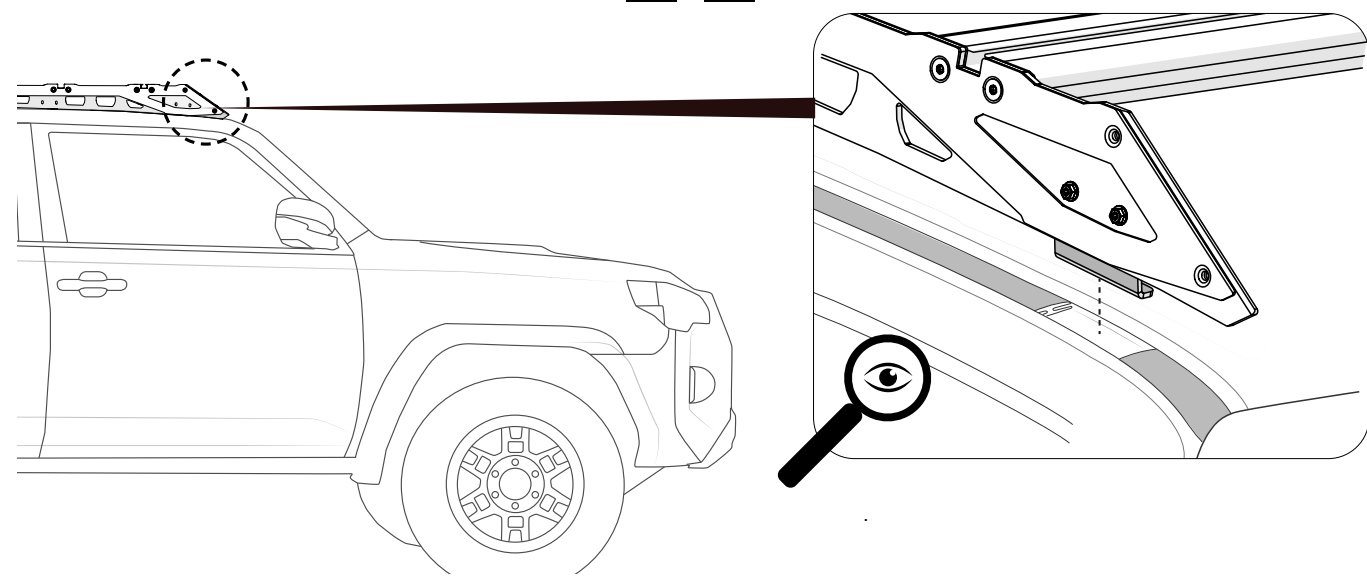

**28** Finger tighten foot to the cast block installed in step **7**.

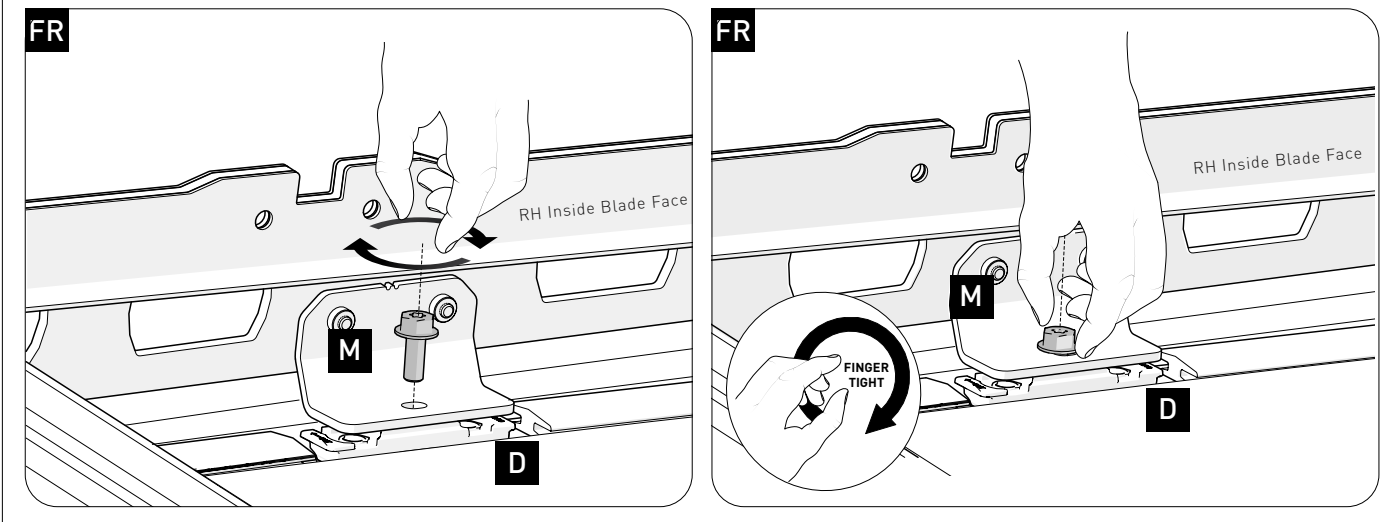

**29** Repeat step **28** for the remaining **3 feet**.

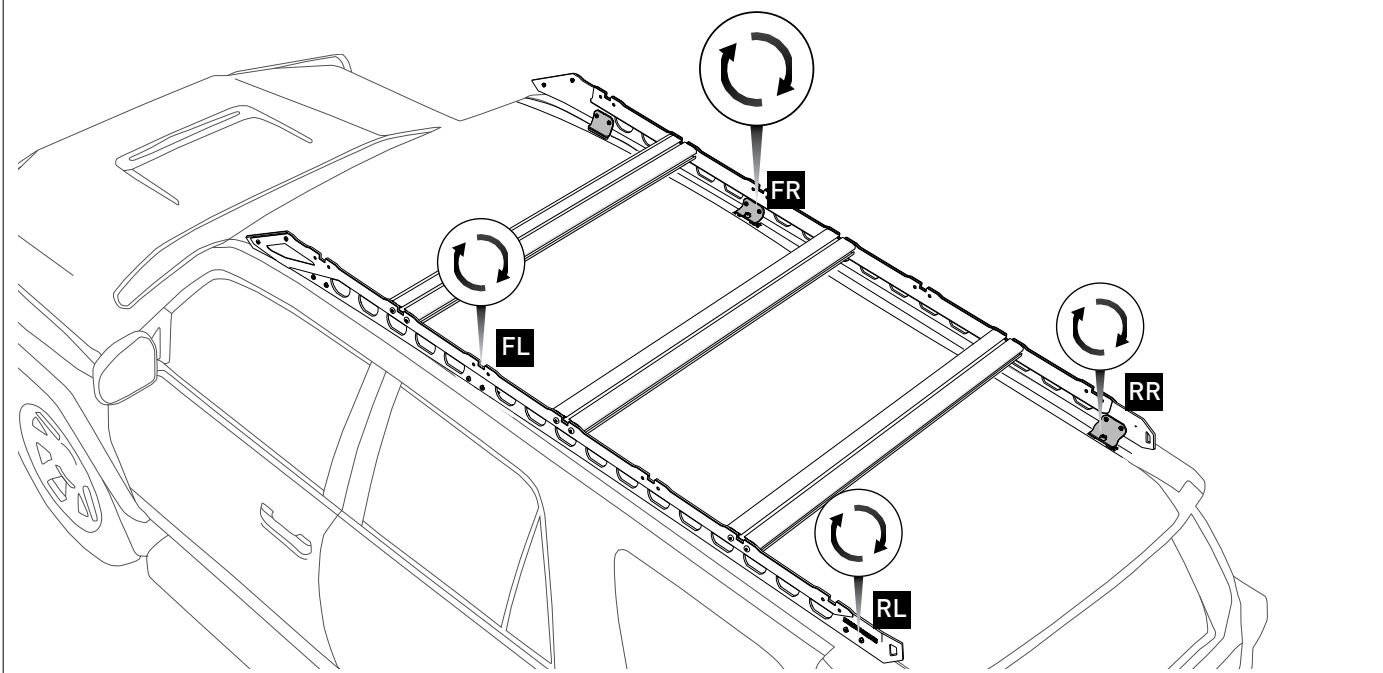

**30**

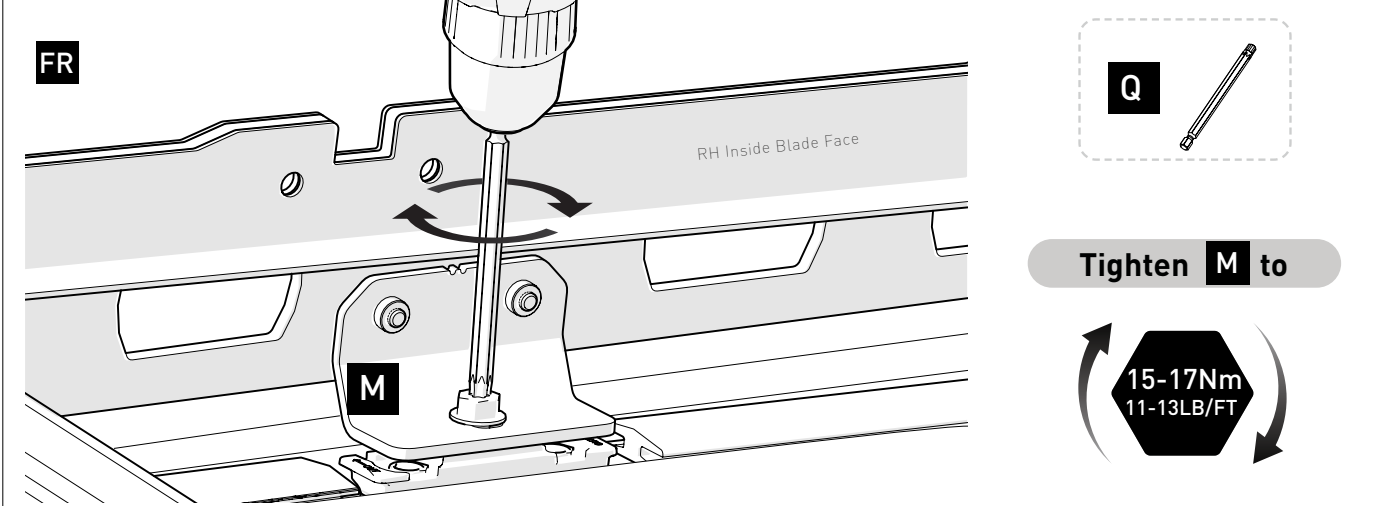

**31** Repeat Step **30** for all remaining feet: Incrementally tighten **M** at all four leg locations.

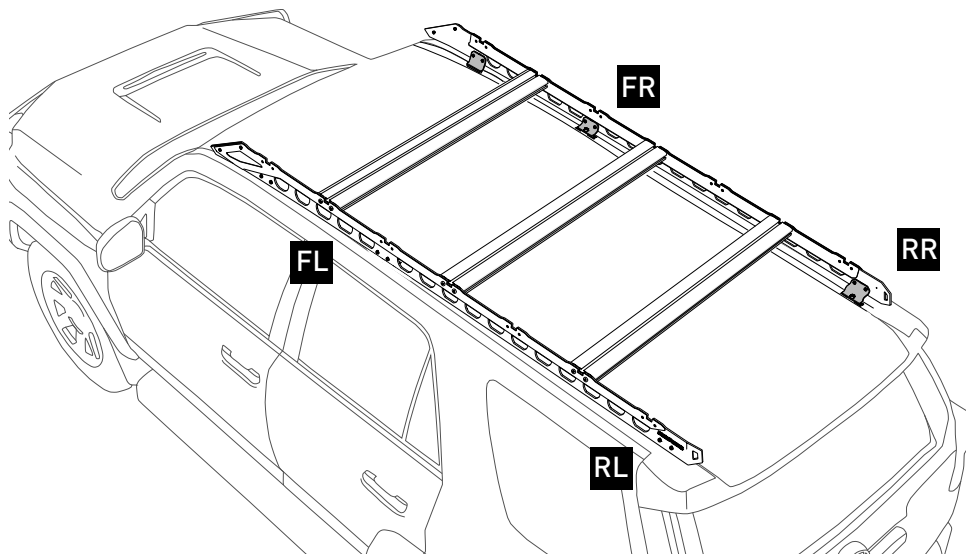

**32**

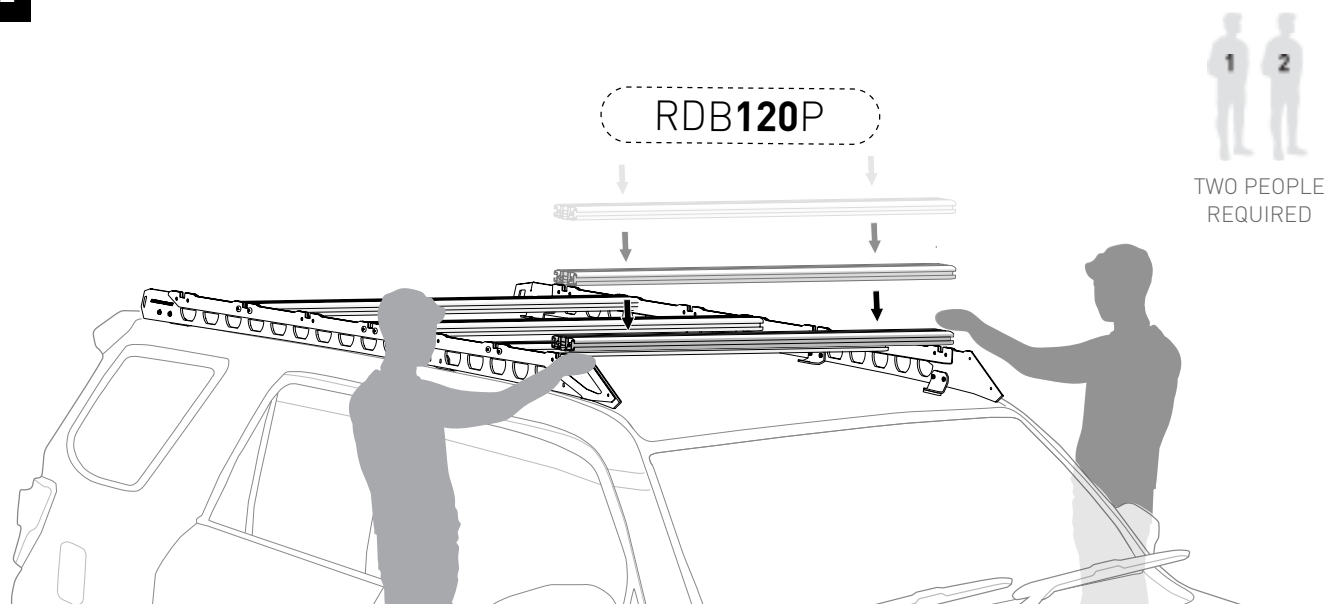

**33**

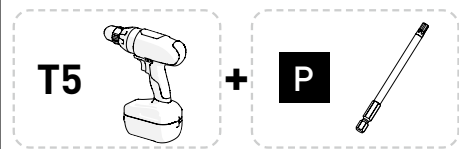

Tighten **K** to



**NOTE**

Other screws may need be loosened to fit **RDB120P** bars in position.

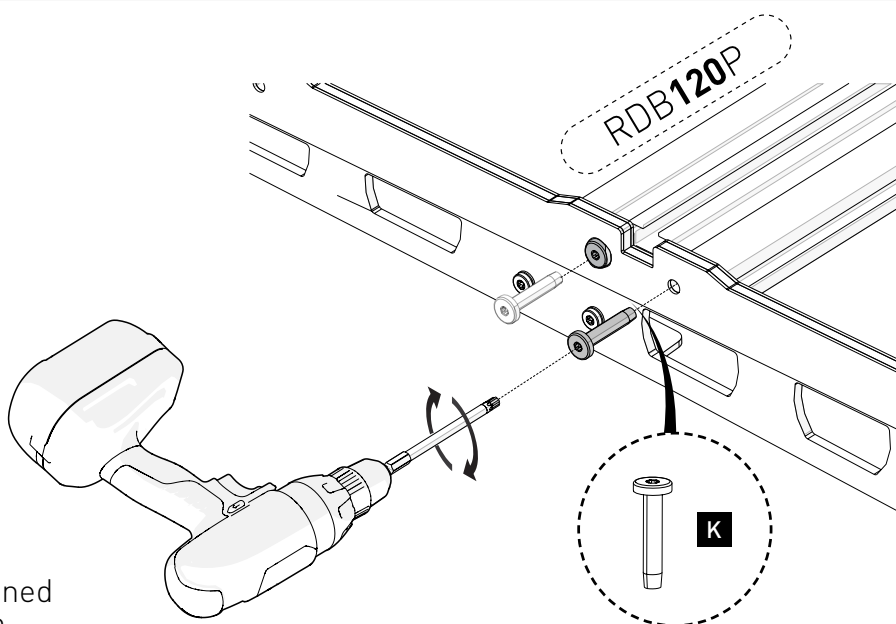

**34** Repeat steps **32** & **33** on both sides for all **3** remaining **RDB120P** Bars.

**RDB120P** x3

**1** **2**  
TWO PEOPLE  
REQUIRED

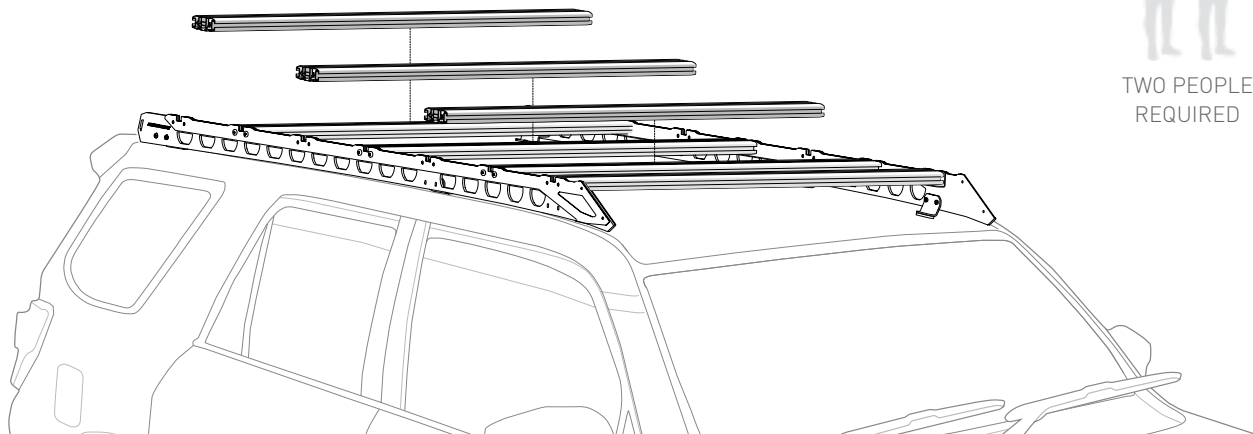

**35**

**1** **2**  
TWO PEOPLE  
REQUIRED

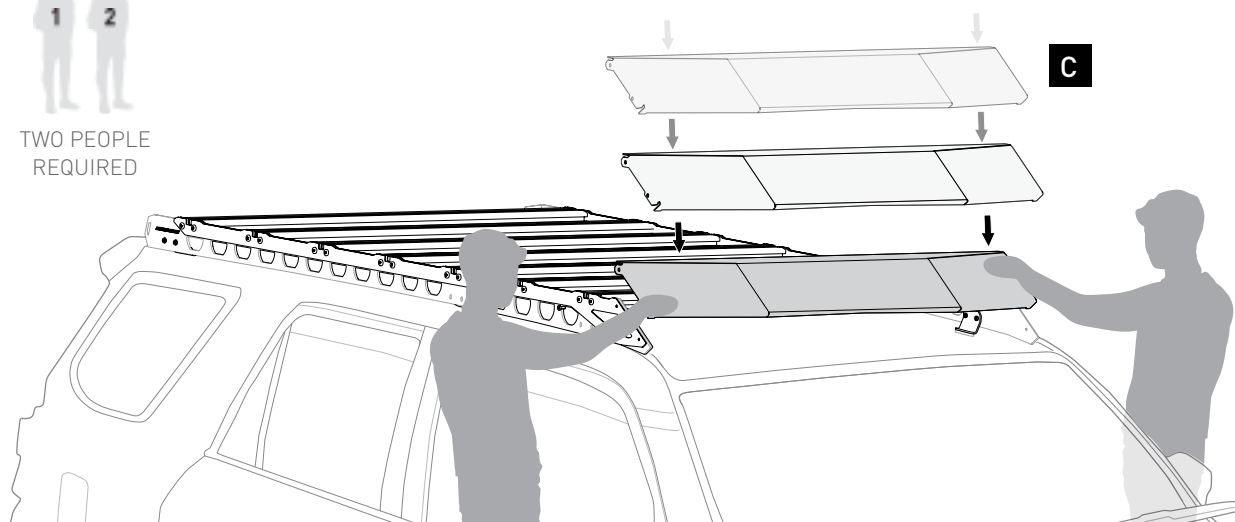

**36**

Tighten **O** x4 to

**6Nm**  
4.4LB/FT

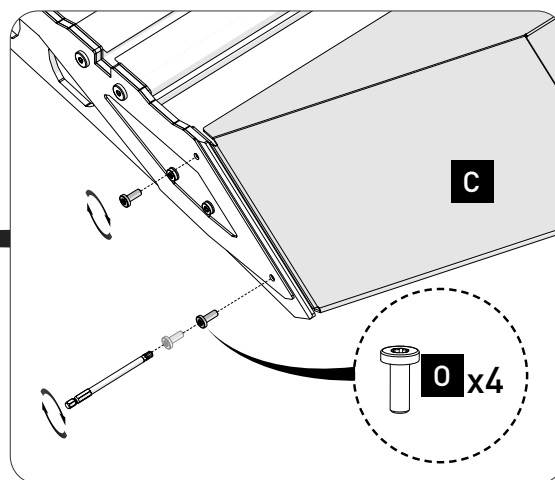

**P**



**Installation** Complete.





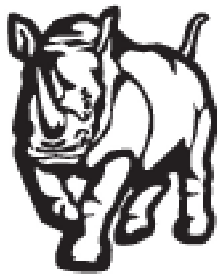

**RHINO-RACK®**

**MAKE SPACE FOR ADVENTURE**

**RHINORACK.COM**

**Rhino-Rack AUSTRALIA**

22A Hanson Pl,  
Eastern Creek, NSW, 2766

**Rhino-Rack USA**

Unit D, 2450 Airport Blvd,  
Aurora, CO, 80011