



# RHINO-RACK®

## Reconn Platform

Toyota 4-Runner Gen 6 SWB

63104

**Important:**

1. Check the Rhino-Rack website to ensure you have the latest issue of these instructions.
2. Please refer to your fitting instruction to ensure that the accessory is installed correctly.
3. Check the contents of kit before commencing fitment and report any discrepancies.
4. Place these instructions in the vehicle's glove box after installation is complete.
5. These instructions must be followed for warranty to be upheld.

**Fit Time:** 90 mins

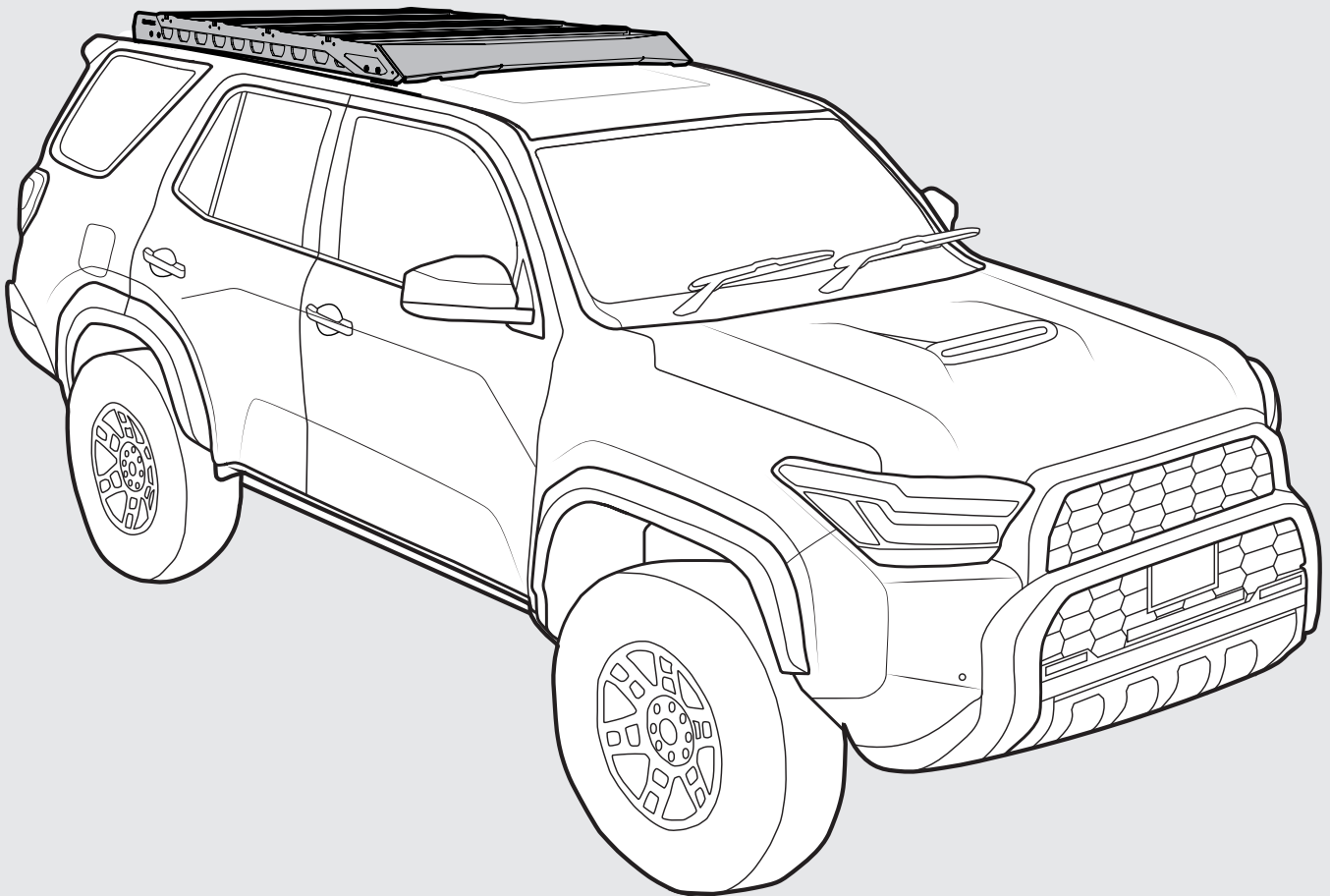

**Thank you for choosing Rhino-Rack!**



**WELCOME TO THE HERD.**

For peace of mind register your product by heading to [rhinorack.com/register](https://rhinorack.com/register)

**RHINORACK.COM**

Document No: 520-RFI-00273



Issue No: 01

Issue Date: 01/09/2025

# Toyota 4-Runner Gen 6 SWB

## DYNAMIC LOAD LIMIT :

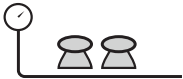
**\*USE THE VEHICLE MANUFACTURER'S MAXIMUM ROOF ALLOWANCE IF IT IS LOWER THAN THE FIGURE LISTED**

 CARGO	 SYSTEM WEIGHT	 LOAD LIMIT	OR	 Max kg
UP TO <b>129KG</b> <b>284lbs</b>	+ <b>21KG</b> <b>47lbs</b>	=	UP TO <b>150 KG</b> <b>331 lbs</b>	*VEHICLE MANUFACTURER'S ROOF LOAD LIMIT

 STATIC LOAD LIMIT: UP TO 250KG / 551LBS\*



VISIT THE ONLINE CALCULATOR FOR CURRENT SYSTEM LOAD LIMIT DATA

### VEHICLE HEIGHT ADDED (mm/in)

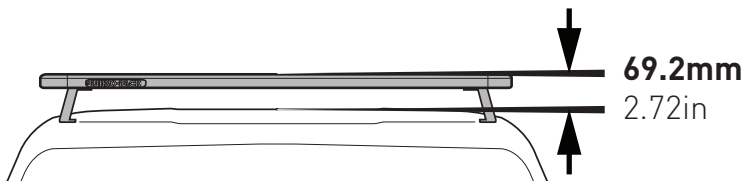





**Do not** exceed a maximum speed of **110 km/h** / **68 mp/h**

Use extreme caution transporting wind-resistant loads when cornering or braking.





Off-road conditions can be more rigorous. Use extreme caution on paths without a sealed surface like tar or bitumen.



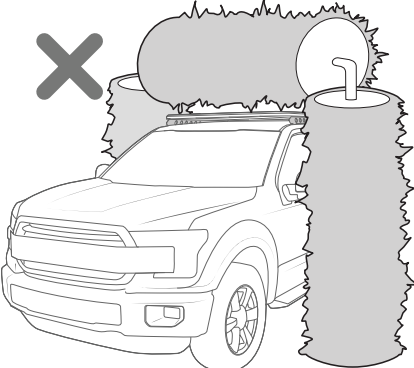

**X**

Racks must be removed when vehicle is put through an automatic car wash.



**!**

Ensure Ladder is well supported on the ground to support tent. Take extreme caution when climbing heights above 1.2m/4ft.

**X** Do NOT obstruct windscreen camera sensors

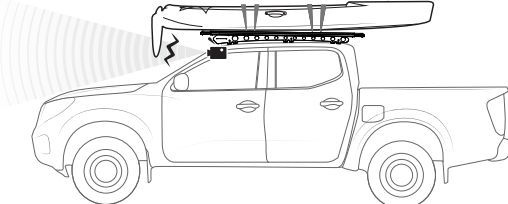

**✓** **!** Warranty for roof rack system will be void if the front of the kayak is not secured to the bonnet

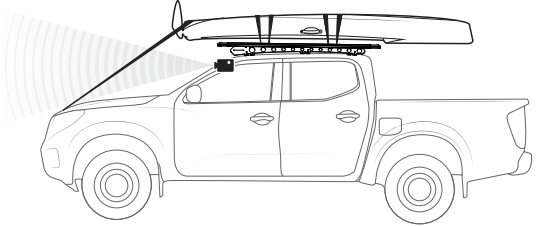

Distribute loads evenly and laterally/longitudinally as low as possible over the span.

Avoid point loads concentrated at the front or rear.

Long flexible loads must attach securely to rigid support and be tied down to the bonnet

Surfboard Overhang > 600mm must be tied to the bonnet

Loads must be tied down to Platform, **NOT** around Backbone

Use only non-stretch fastening ropes or straps to attach cargo to roof racks



Ensure sunroof will not collide with roof rack system.

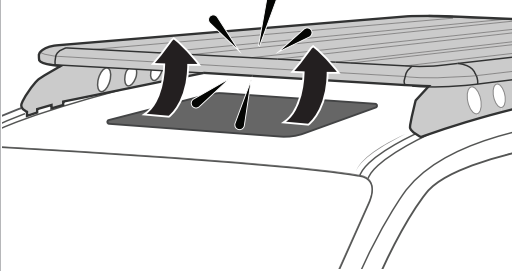

Find another copy of the instruction manual here



Youtube.com/Rhinorackaustralia



### In service maintenance checks

- All bolts should be checked after driving a short distance when you first install your roof racks to ensure none have loosened.
- All bolted connections should be checked again at regular intervals (weekly is recommended, depending on road conditions, usage, loads and distances travelled).
- All bolted connections should be checked each time they are re-fitted.
- Off-road conditions are more rigorous. Check all bolted connections and your load more regularly.
- Ensure that your total vehicle manufacturer’s GVM (gross vehicle mass) and gross axle weights are not exceeded (refer to vehicle owner’s manual).

### Note for Dealers and Fitters

It is your responsibility to ensure these fitting instructions are given to the end user or client. These instructions remain the property of Rhino-Rack Australia Pty. Ltd. and may not be changed or used for any other purpose than intended.

### Torque Settings

Throughout this instruction manual, an impact driver can be used to speed up installation. However, it is important to ensure that the final turns are completed with a torque wrench to achieve the required torque rating.

Take caution when using an impact driver, as excessive torque can result in stripped threads.



#### Torque Settings:

Unless stated otherwise in these instructions, all fasteners should be set to the following torque settings:

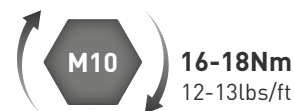

### What you should have

To complete this build/ fit you will need.

#### RECONN SYSTEM COMPONENTS

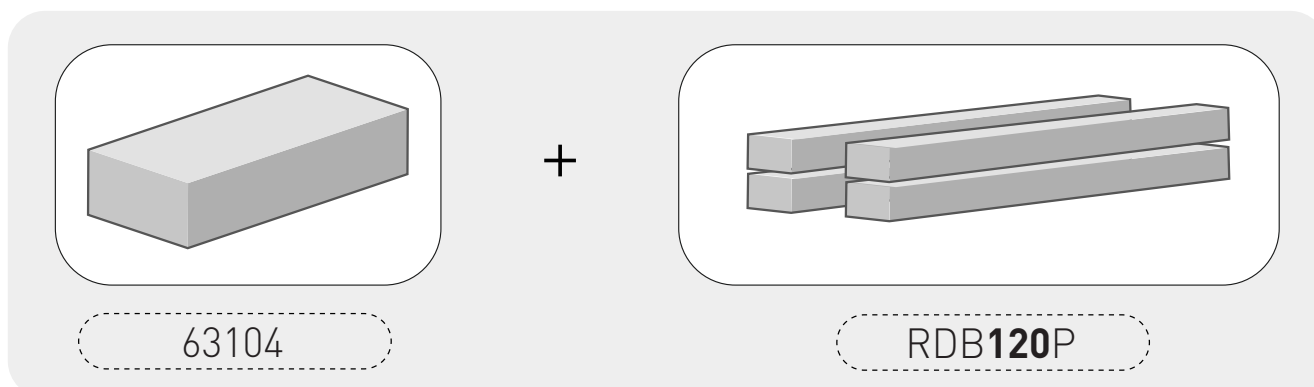

Parts List

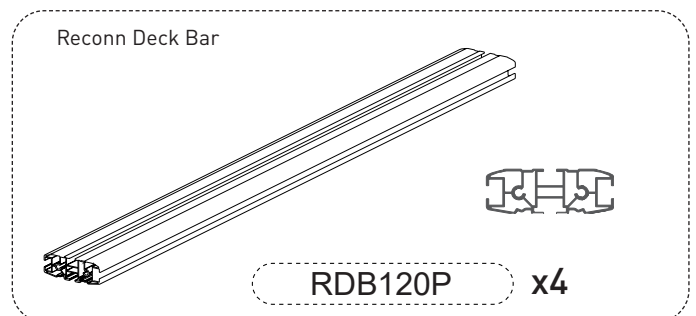
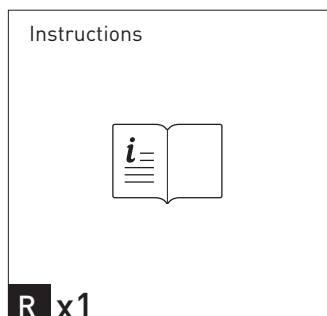
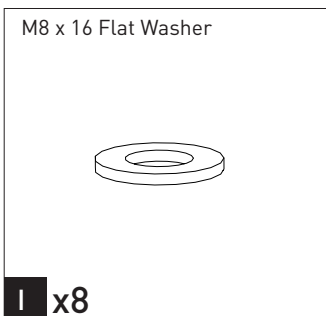
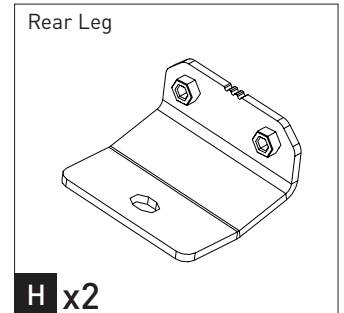
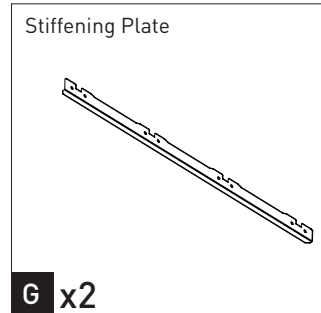
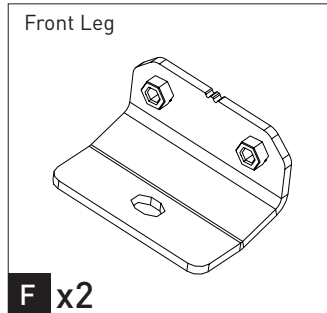
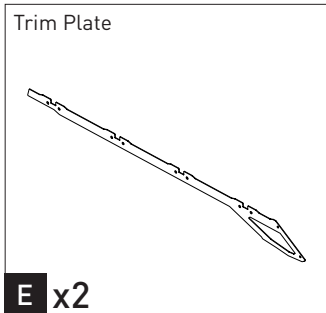
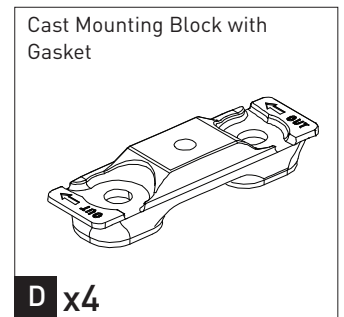
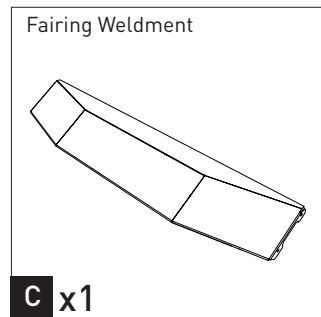
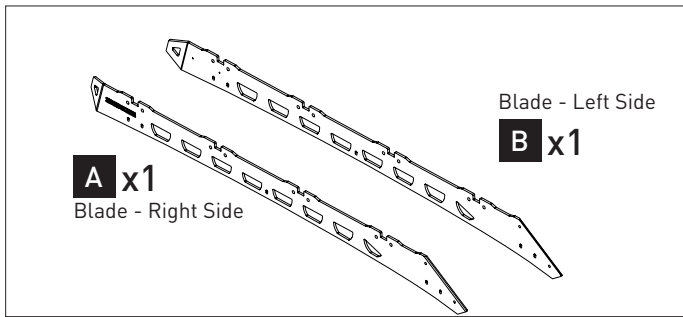

Tools Required:

- T1 - Tape Measure
- T2 - Cutting Tool
- T3 - Marker/Pen
- T4 - Impact Driver
- T5 - Cleaning Rag
- T6 - Torque Wrench (13mm Socket)
- T7 - Trim Tool - Fork Head
- T8 - Torque Wrench (12mm Socket)

P1

## RAISED RAIL

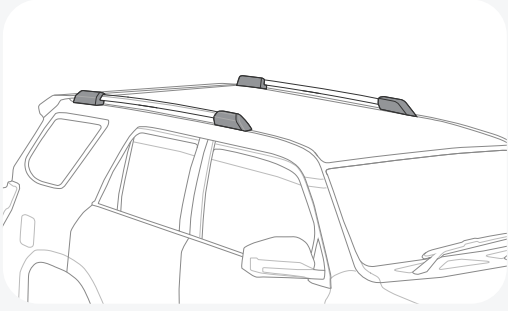
Proceed Here **Steps 1 - 4**

## BARE ROOF

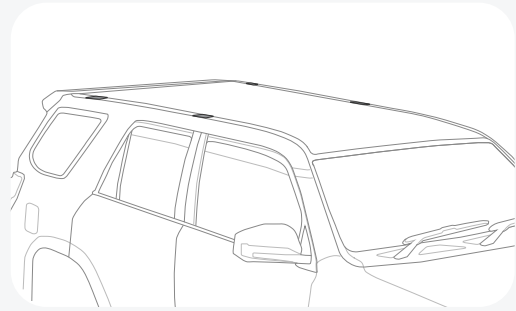
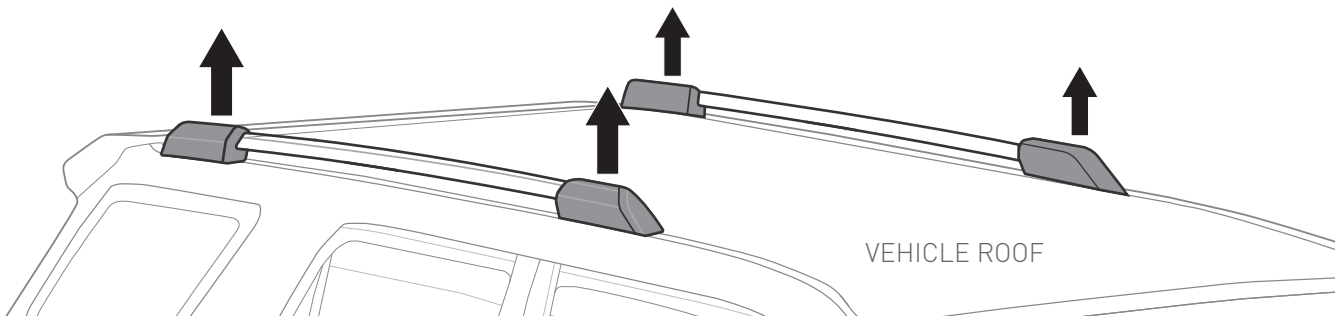
Skip to **Steps 5 - 7****1** Remove all end caps.**1a** Remove rear cover using **T7** by carefully pressing around all edges.

Do not lever against the painted roof.

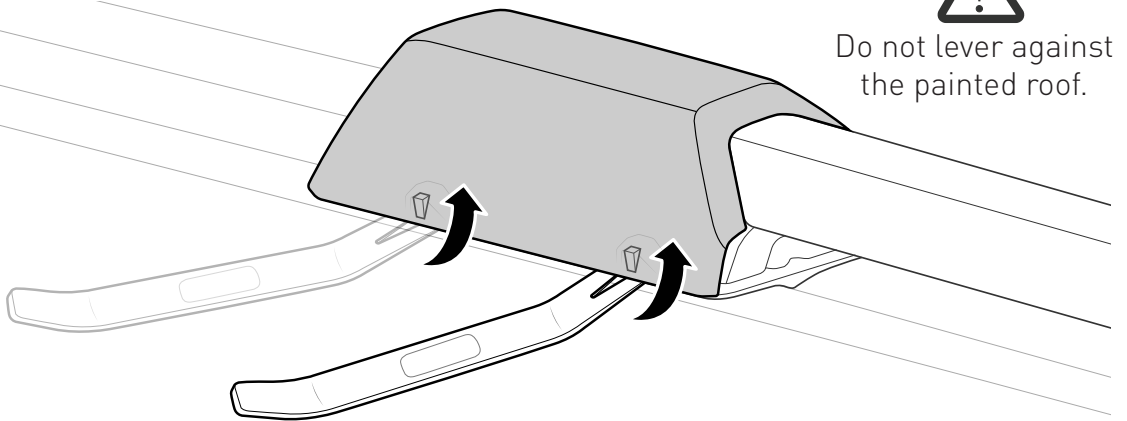
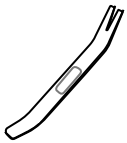
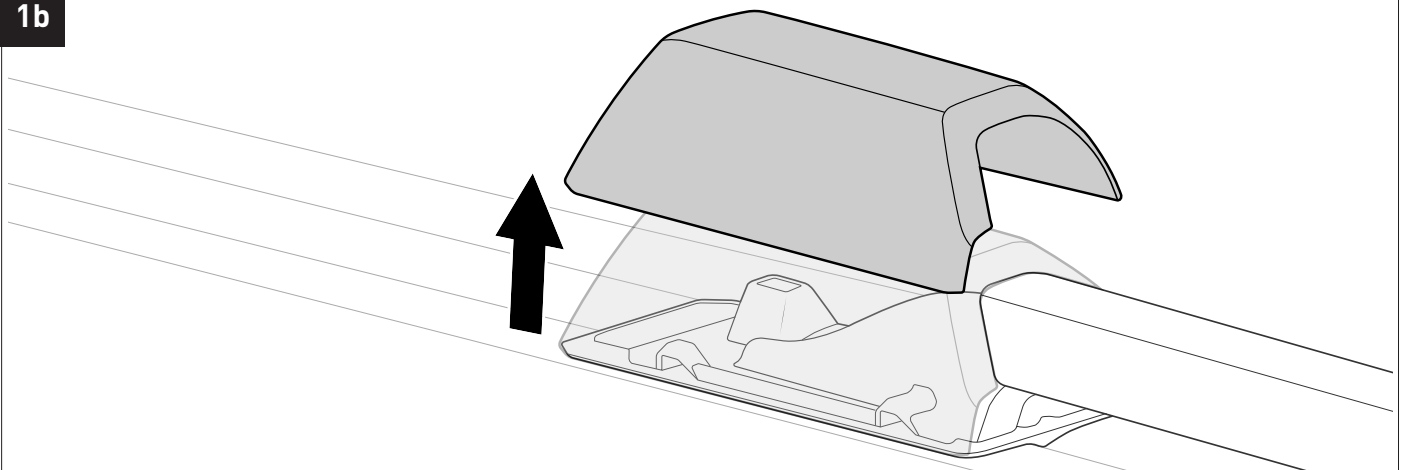
**T7****1b**

**1c** Remove front cover using **T7** by carefully pressing around all edges.

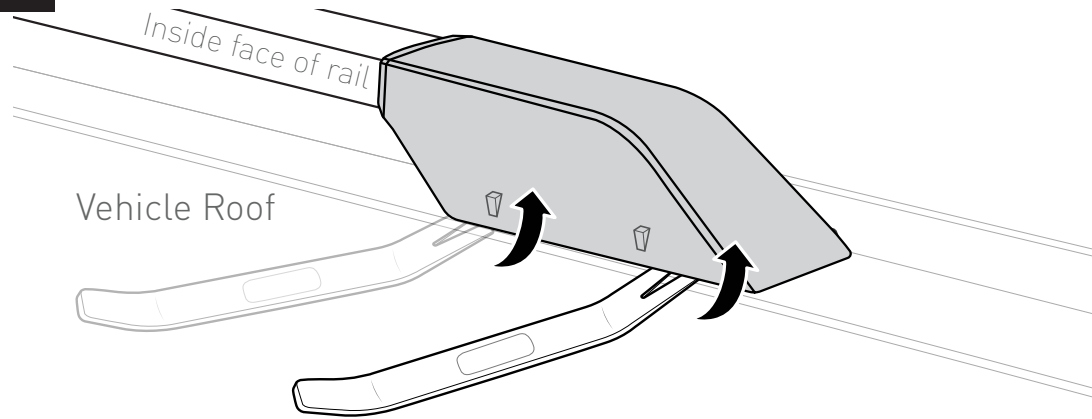

Do not lever against the painted roof.

**T7**

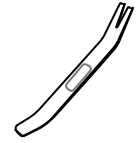

**1d**

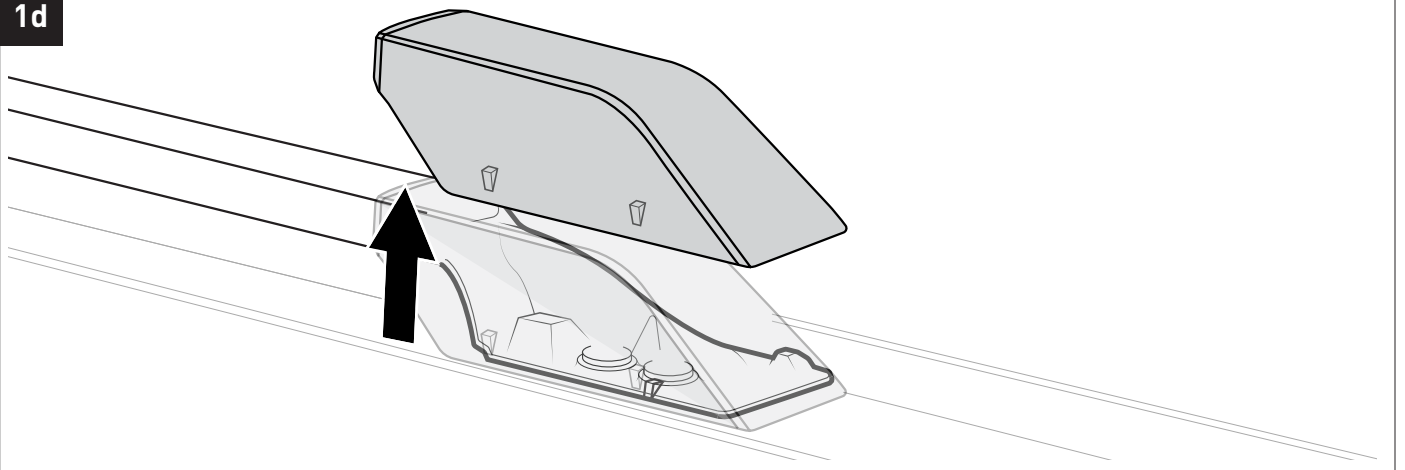

**2a**

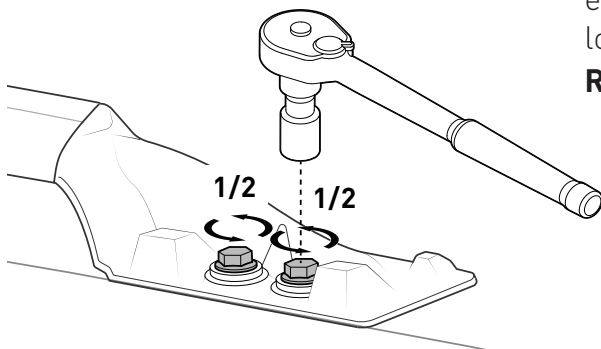

Break both bolts loose, incrementally turning each a half turn at a time, until they are both loose enough to remove by hand.

**Repeat removal for rear rail bolts.**

**T8**

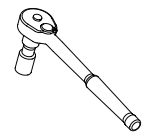

**2b**

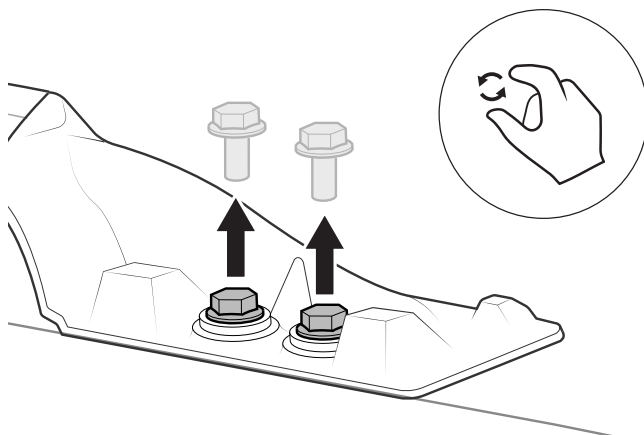

Ensure both bolts are loose before removing either bolt completely.

Failure to do so may lead to the internal threaded roof plate being dislodged.

**NOTE:** Store hardware in a safe place.

**3** Remove rails by lifting vertically.

**NOTE:** Store in a safe place.

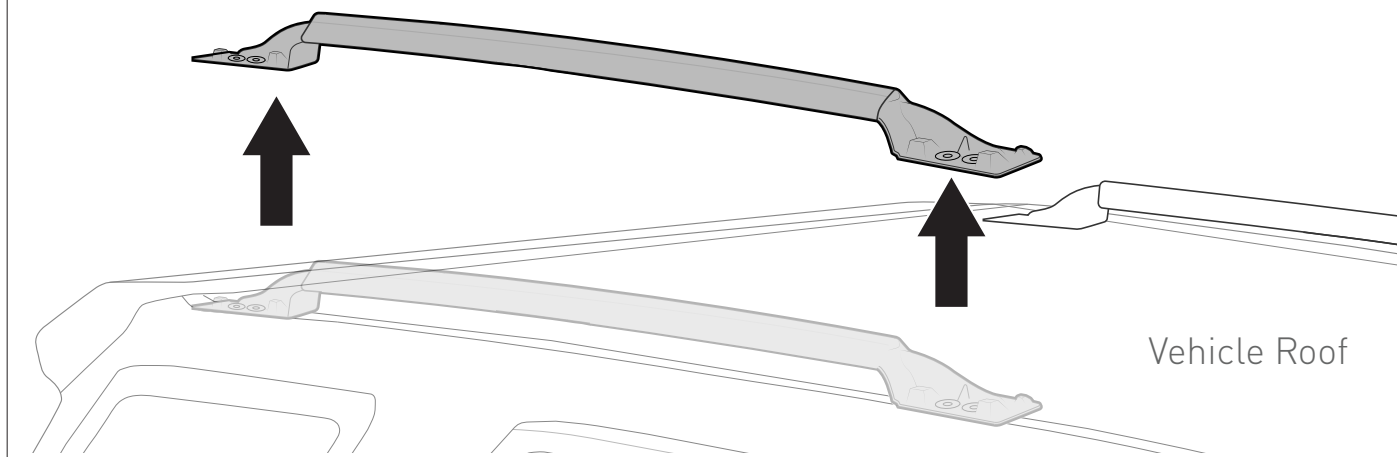

**Raised Rail** Removal Complete. **Skip to step 8**

**4** Remove mounting point covers (two per side).

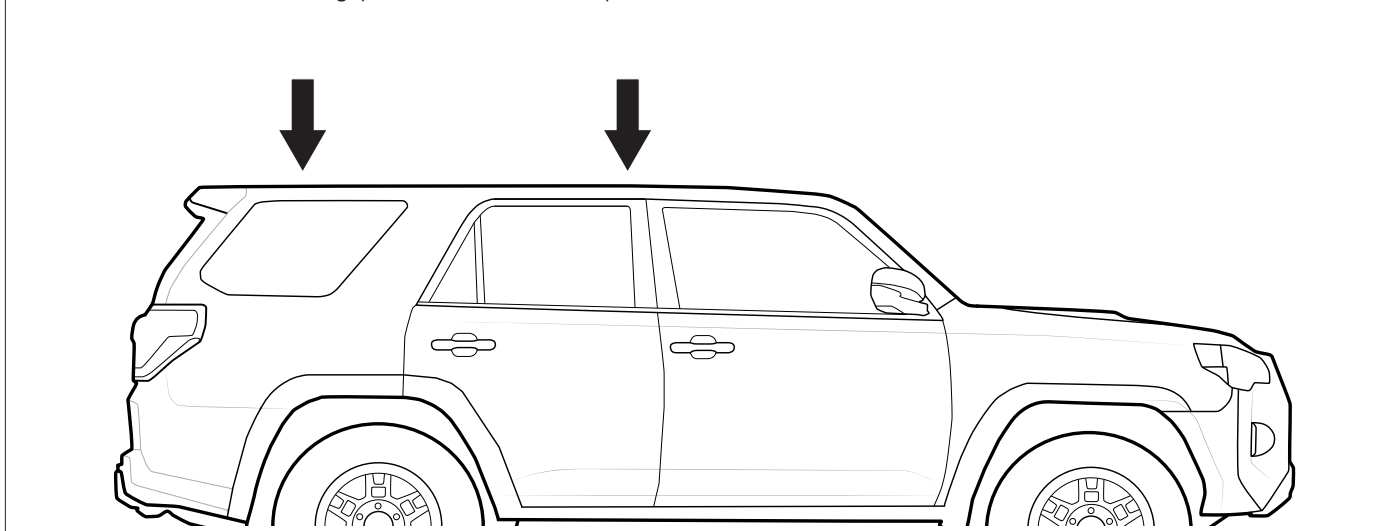

**4a** Lift end while pushing in the direction of the arrow.

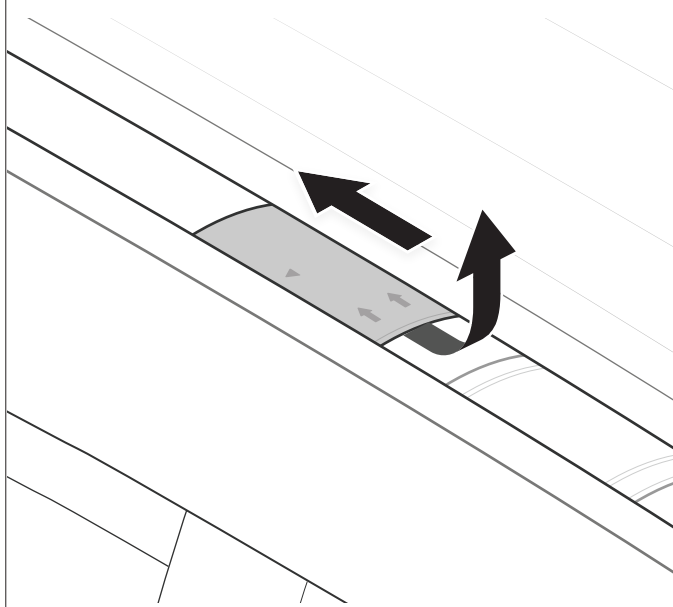

**4b** **NOTE:** Store covers in a safe place.

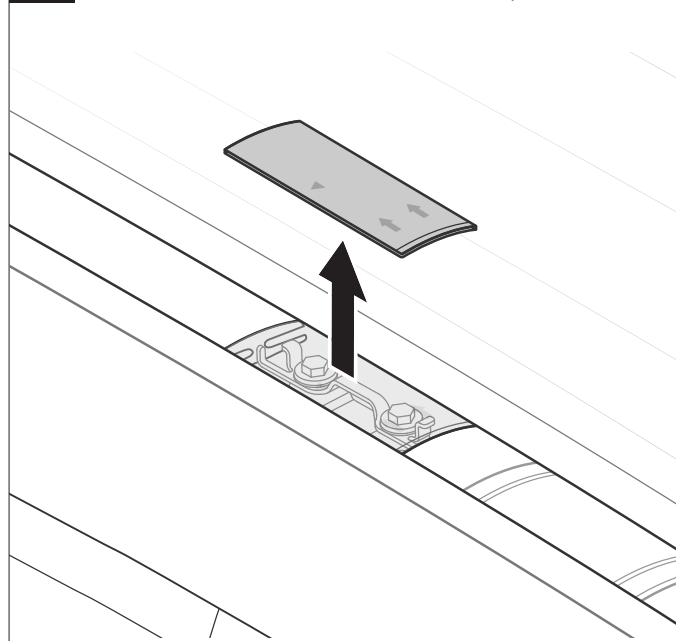

**5a** Break both bolts loose, incrementally turning each a half turn at a time, until they are both loose enough to remove by hand.

Remove factory bolts and hooks from selected mounting points.

**NOTE:** Store hooks and hardware in a safe place.

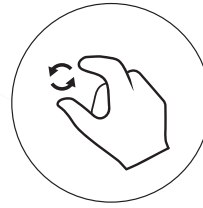
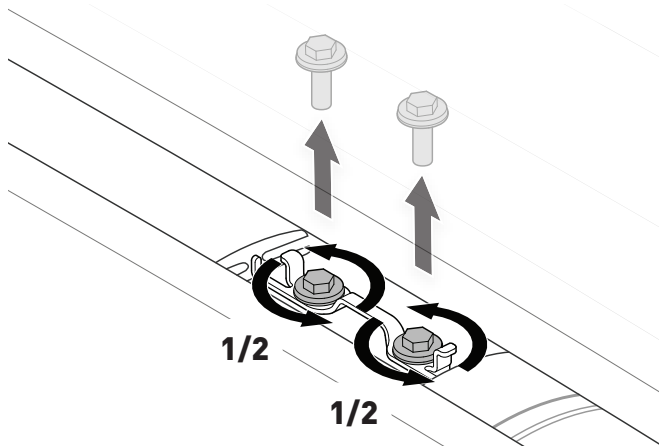

Ensure both bolts are loose before removing either bolt completely.

Failure to do so may lead to the internal threaded roof plate being dislodged.

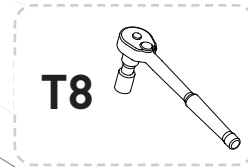

**5b**

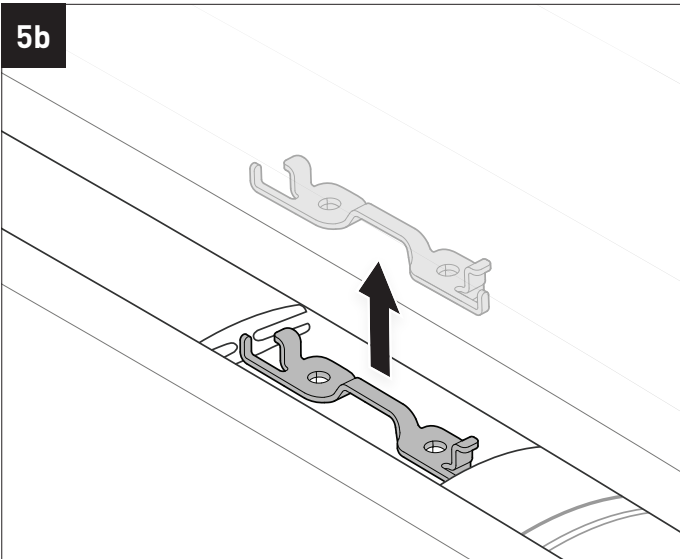

**5c**

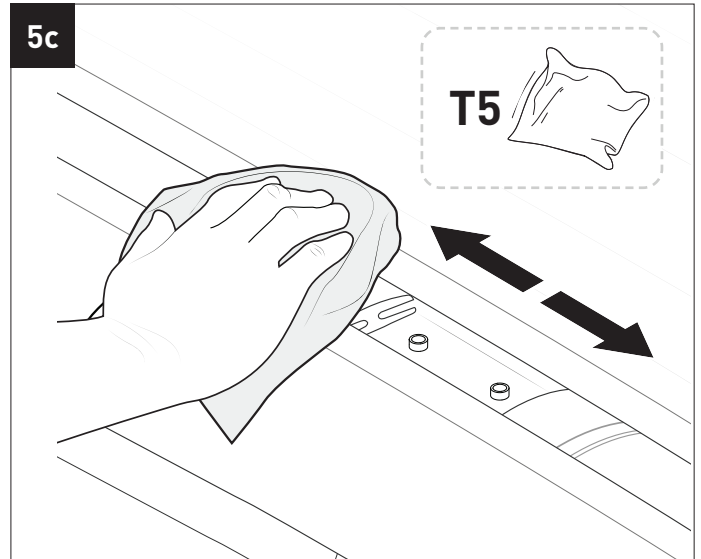

**Bare Roof Removal Complete.**

**P2**

**6a** Use tapping screws **P** to remove any threadlock buildup from the existing thread.

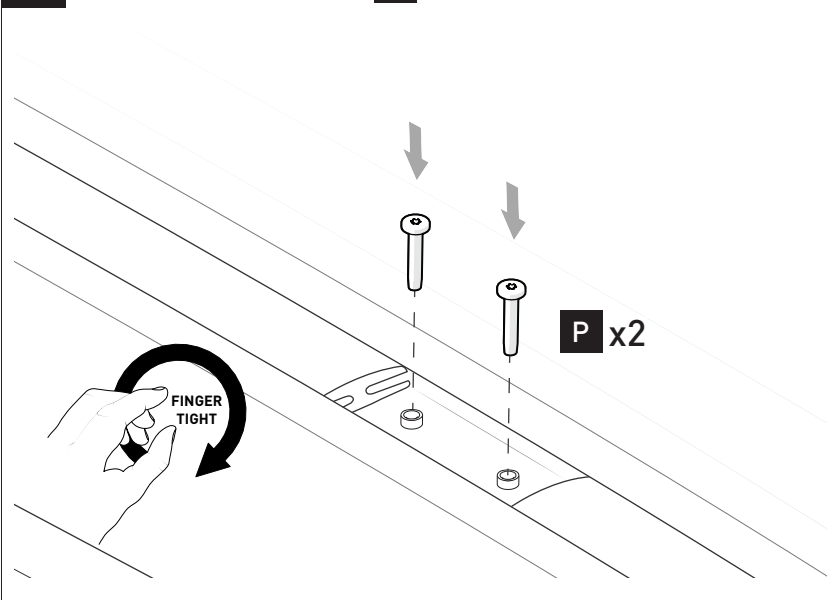

Operation should always be carried out with both screws engaged so that the internal roof plate is not dislodged.

Failure to do so may lead to the internal threaded roof plate being dislodged.

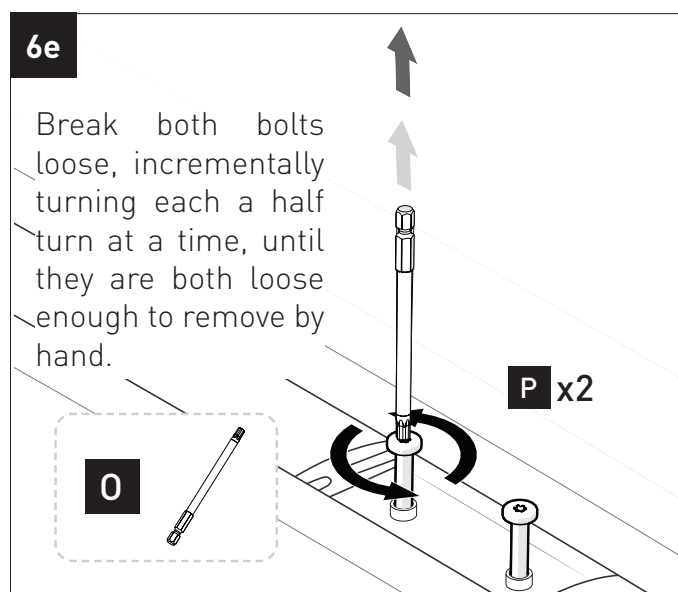
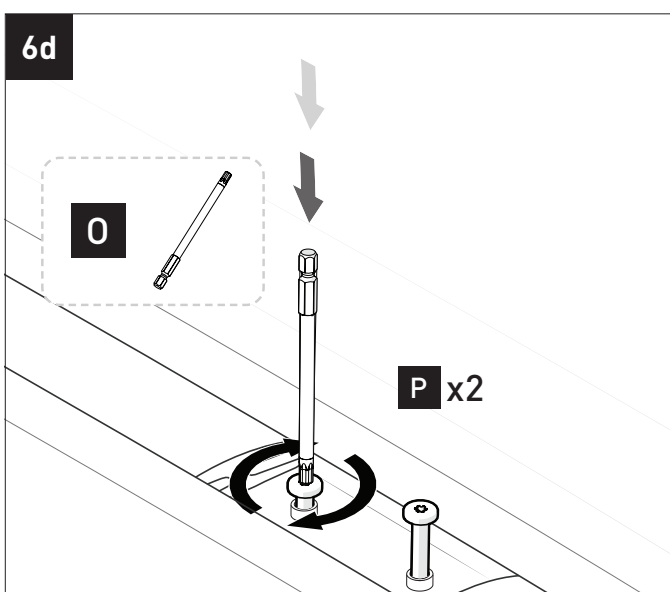
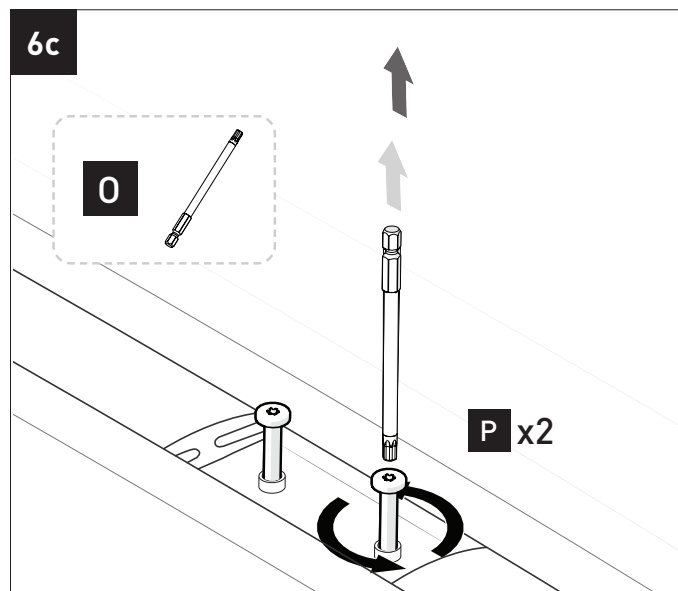
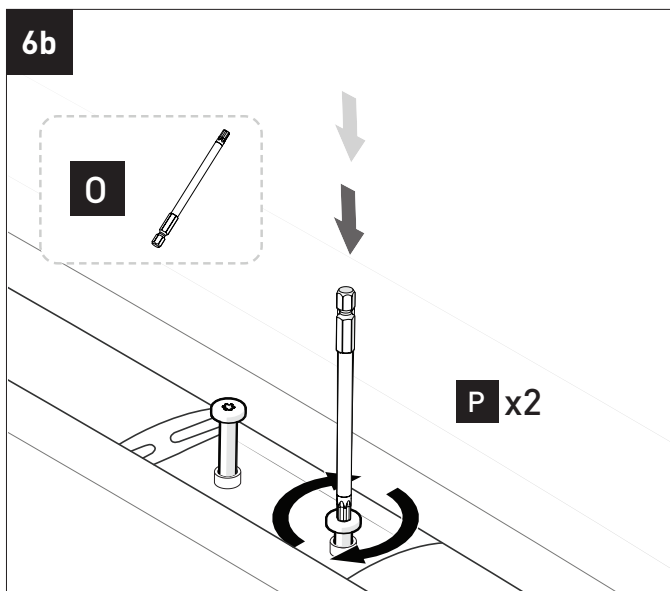

Repeat steps **6a** to **6e** for all 6 mounting points.

**7** Assemble mounting blocks (2 per side) with supplied flanged bolts. Insert both bolts simultaneously and gently into the internal roof plate and finger tighten.

Ensure both bolts are inserted by hand before using **T6** to tighten.

Failure to do so may lead to the internal threaded roof plate being dislodged.

8

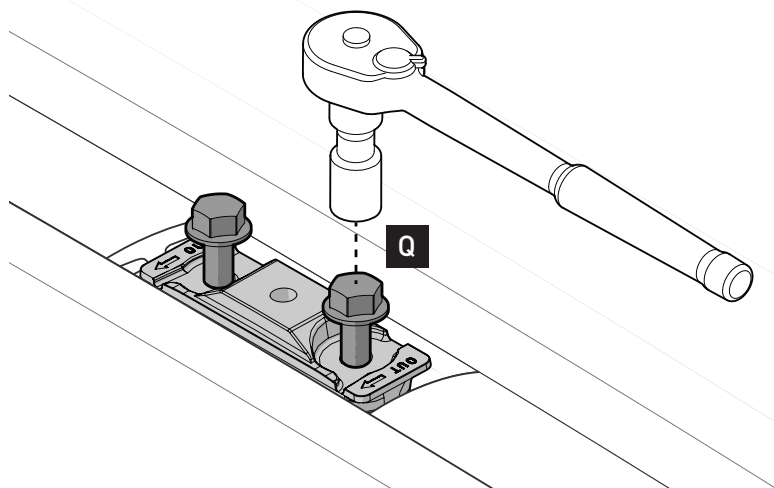

Once both bolts are threaded into the internal roof plate, use **T8** to tighten.



**NOTE**

The rear ends angle inward toward the center of the vehicle, indicating the left and right blades.

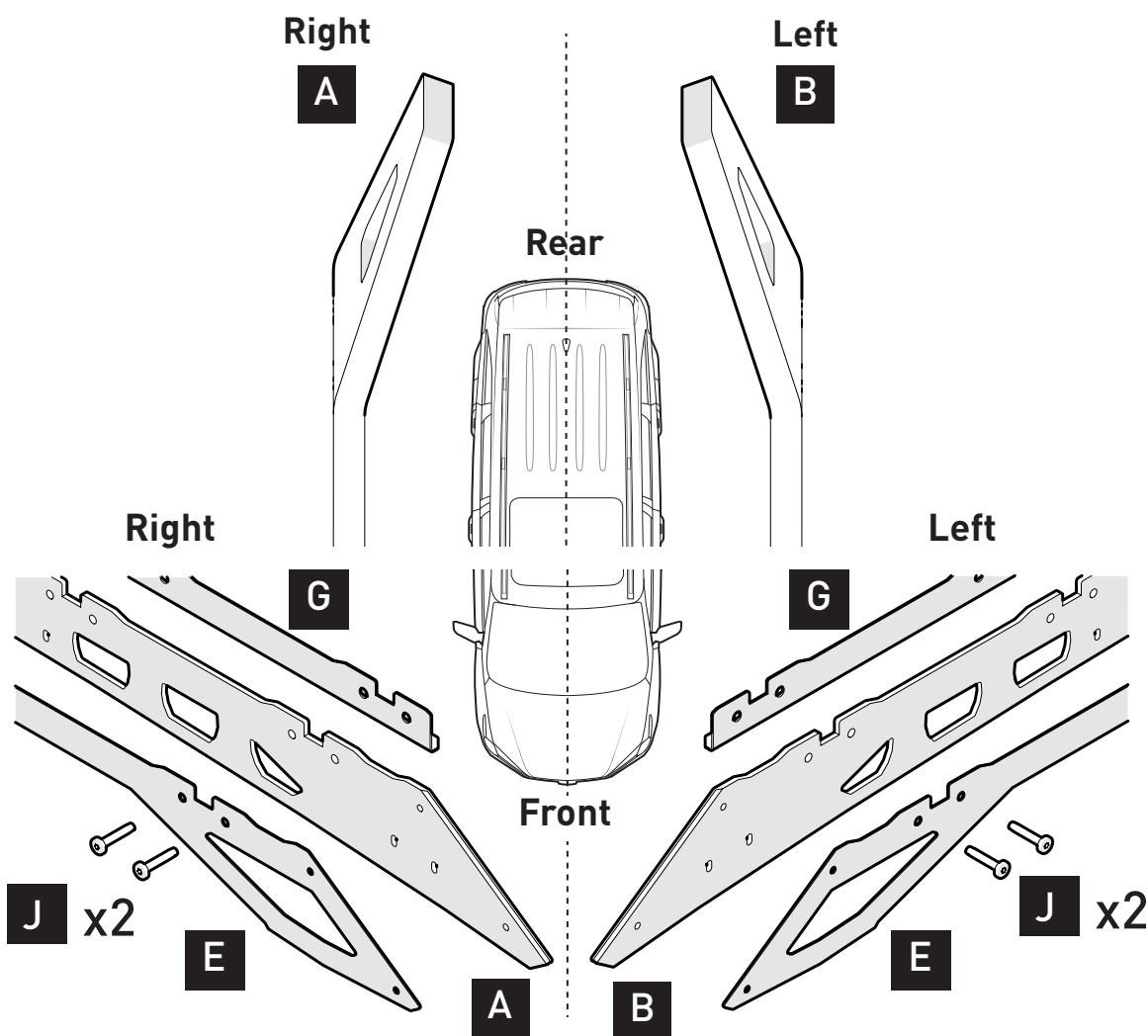

**9** Loosely assemble **2x bolts** at each of the **3 indicated locations** on **left side blade**.

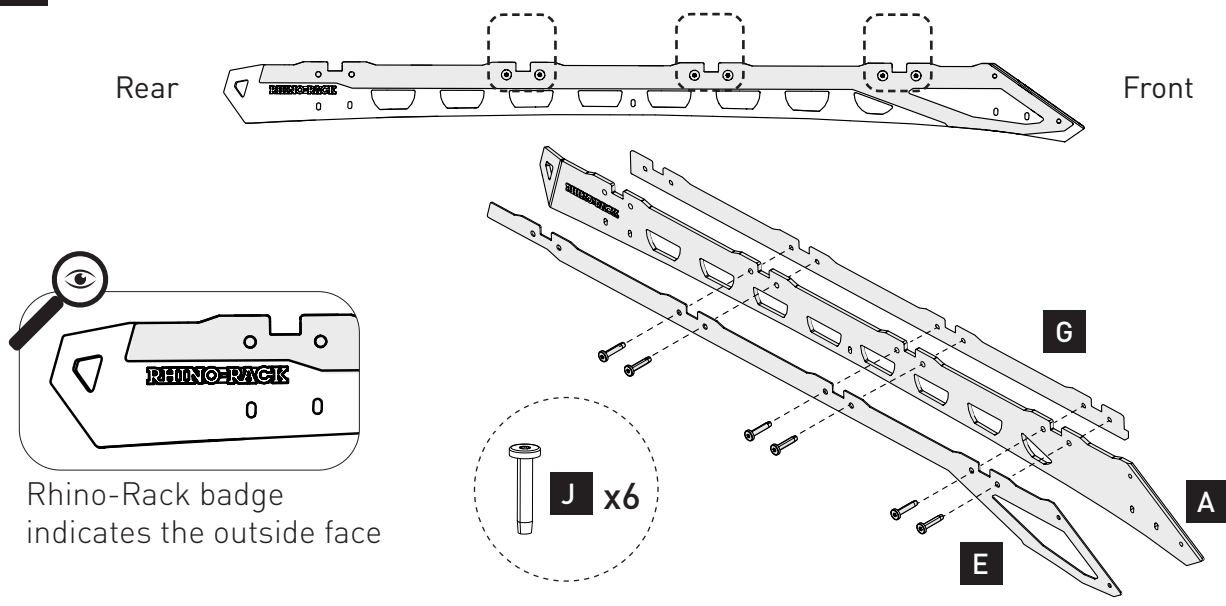

**10** Loosely assemble **2x bolts** at each of the **3 indicated locations** on **right side blade**.

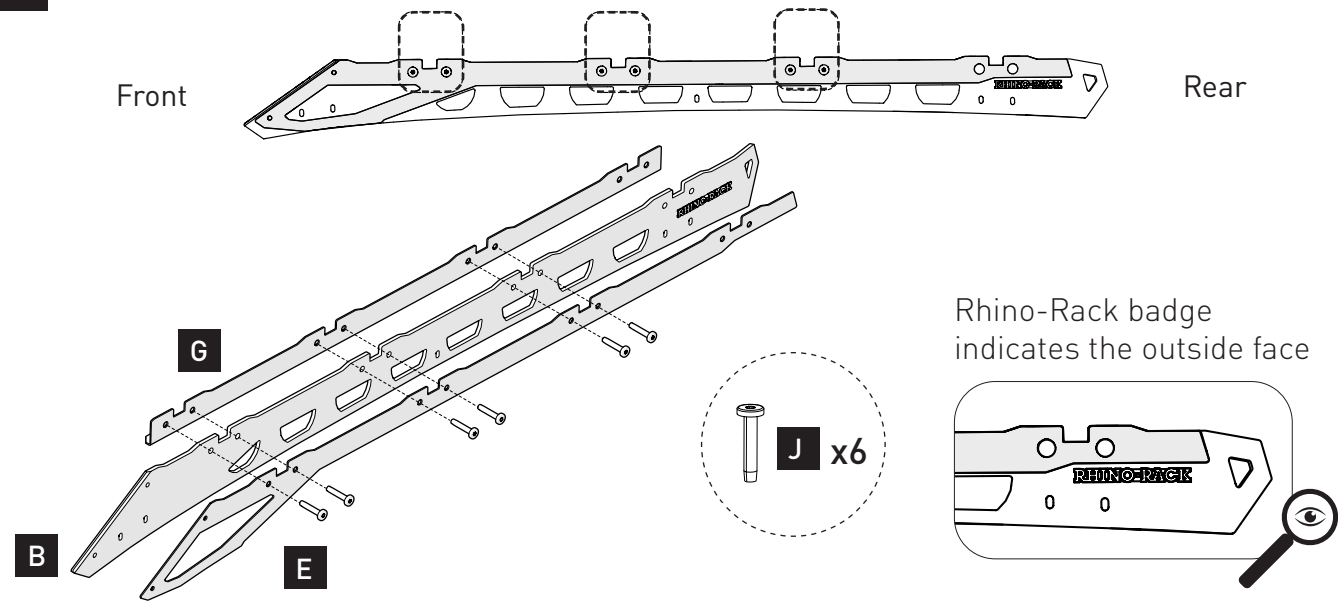

**11** Ensure that **H** is positioned correctly on both left & right blades.

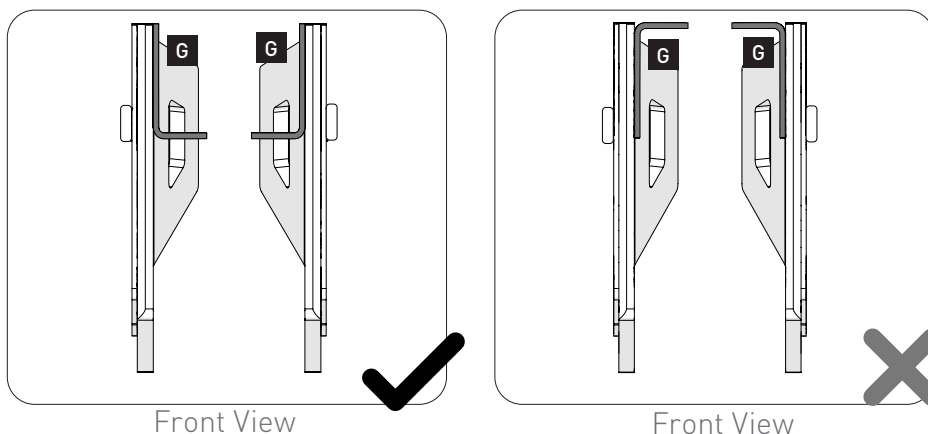

**12** Flip blade assemblies.

**NOTE**

Upside-down Rhino-Rack badge indicates the correct orientation

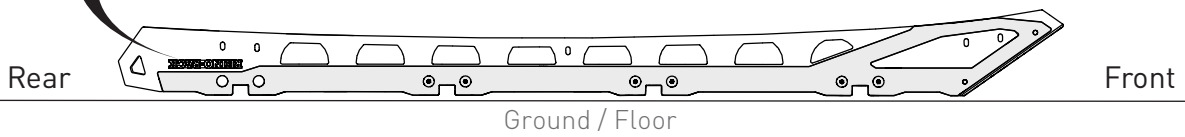
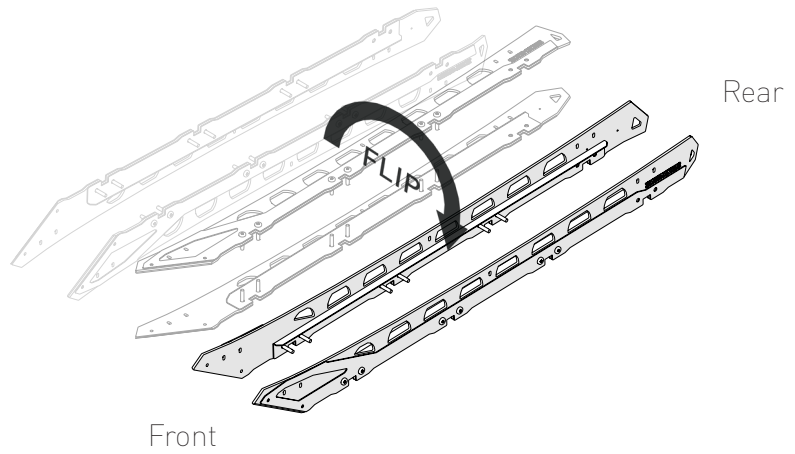
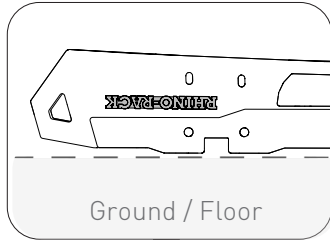

**13** For easier handling, use **P** silver screws pre-tap **3x** RDB120P bars at both ends.

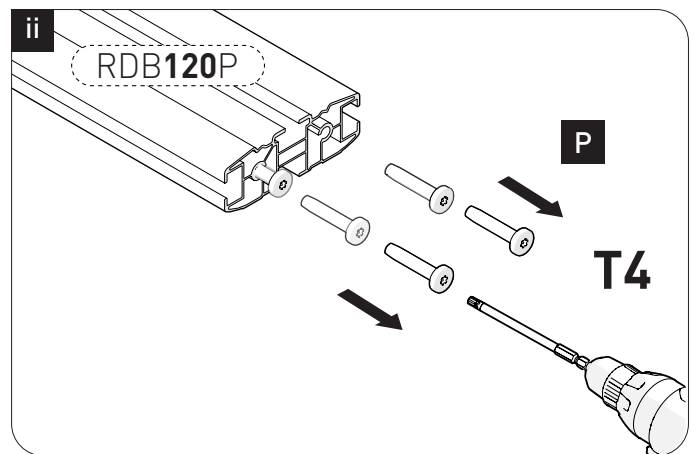
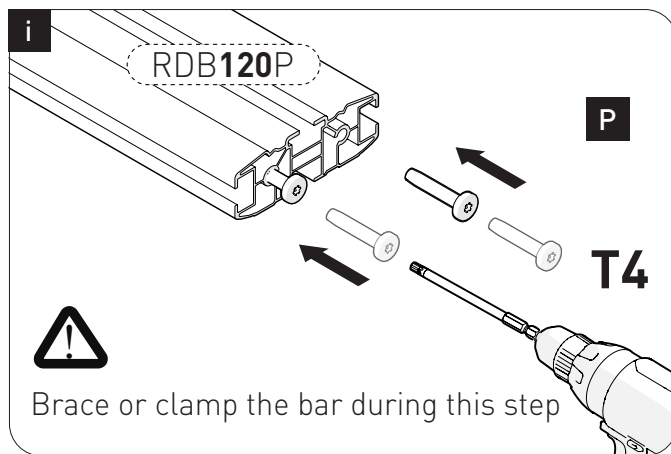

**14** Screw **3x** RDB120P bars to right hand blade assembly.

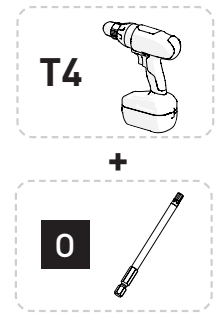
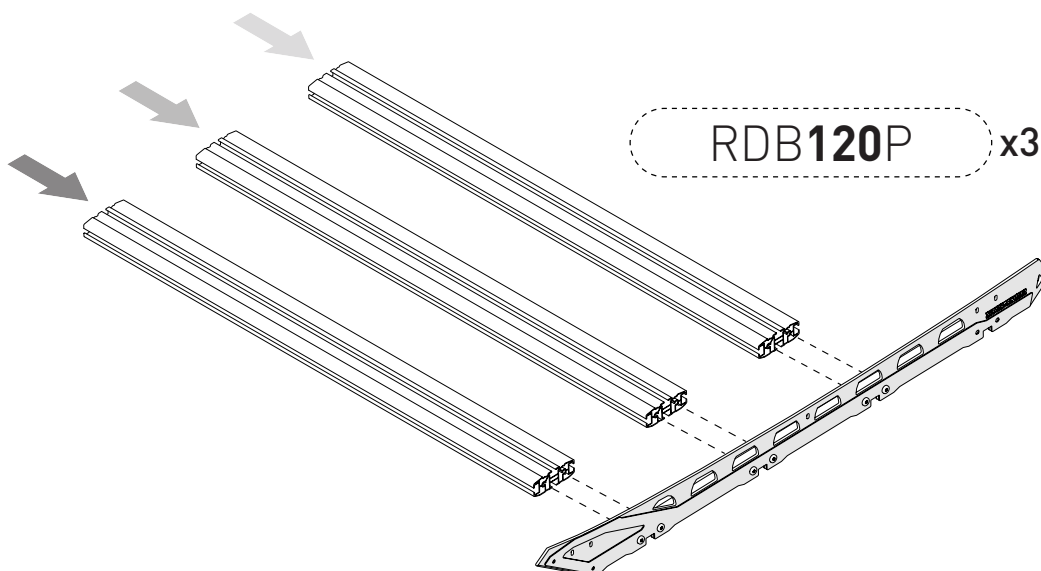

15

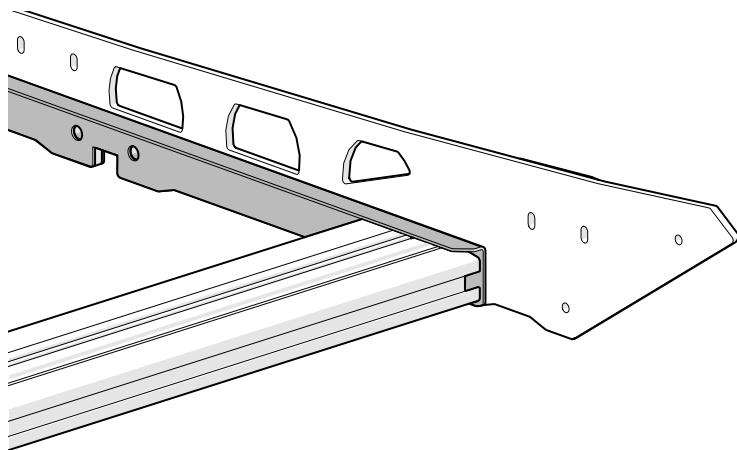
**NOTE**Ensure **RDB120P** Bars sit under **G**

16

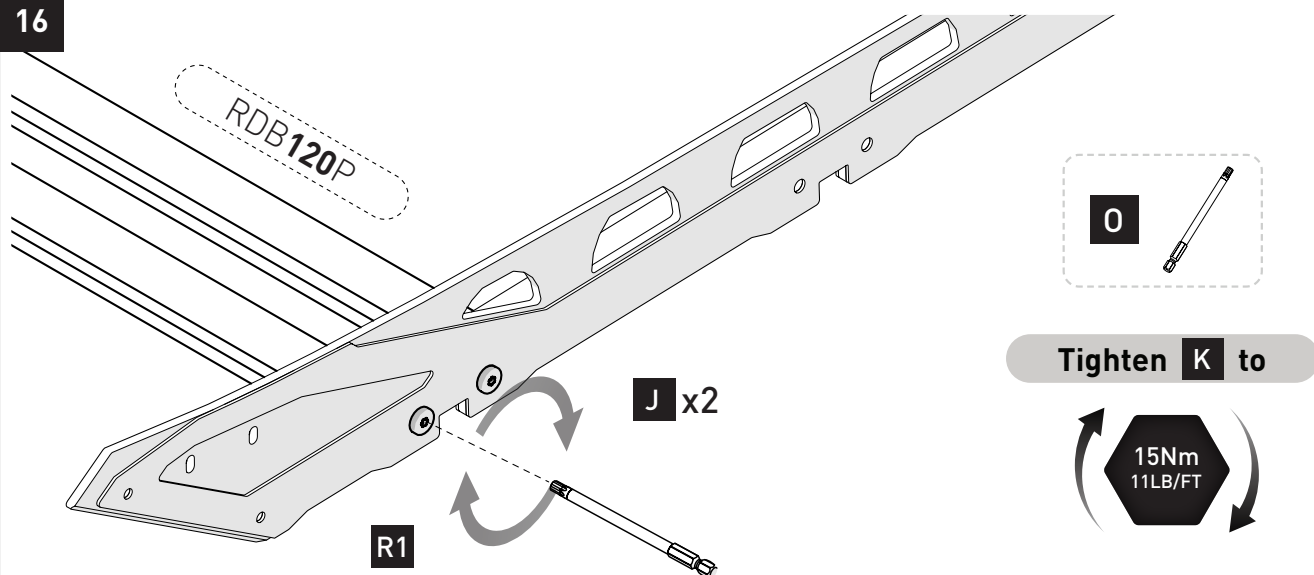

17

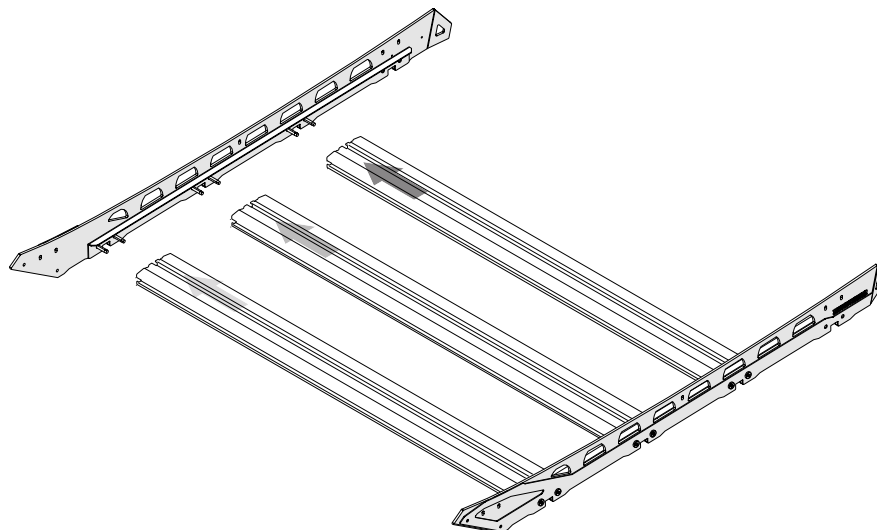
Repeat steps **14** to **15** on left hand blade assembly.

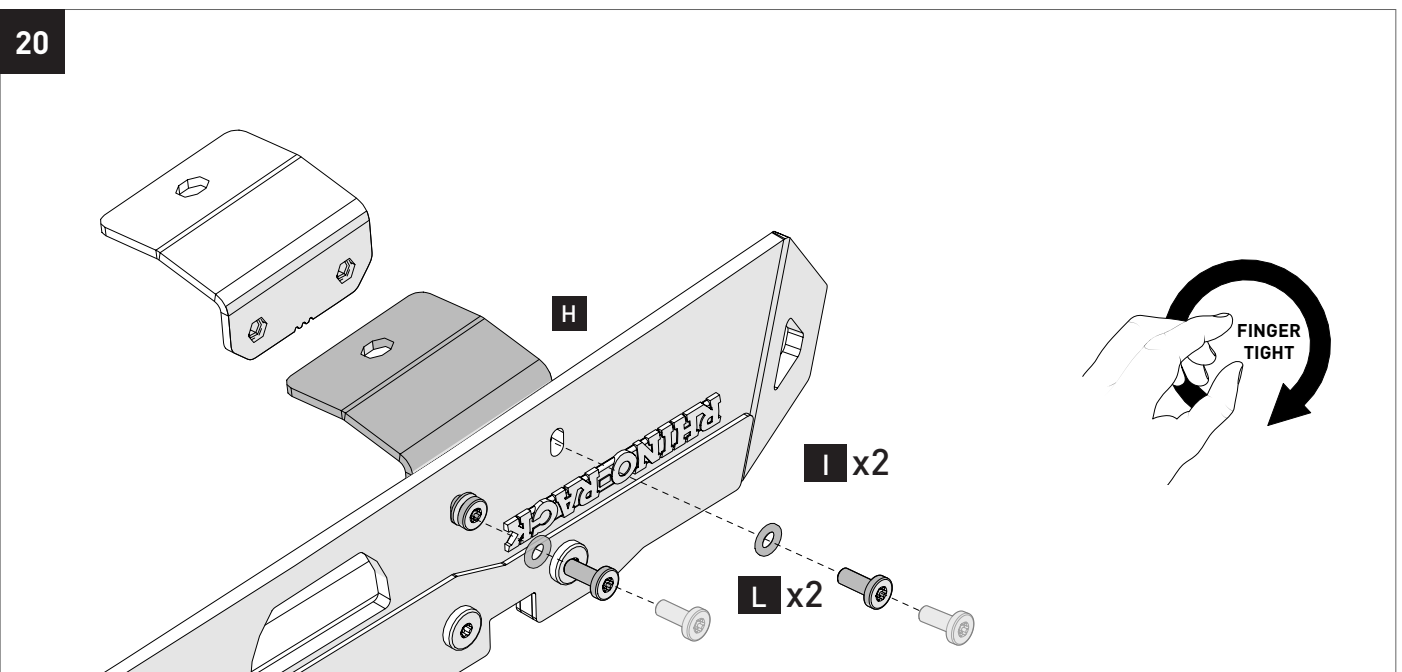
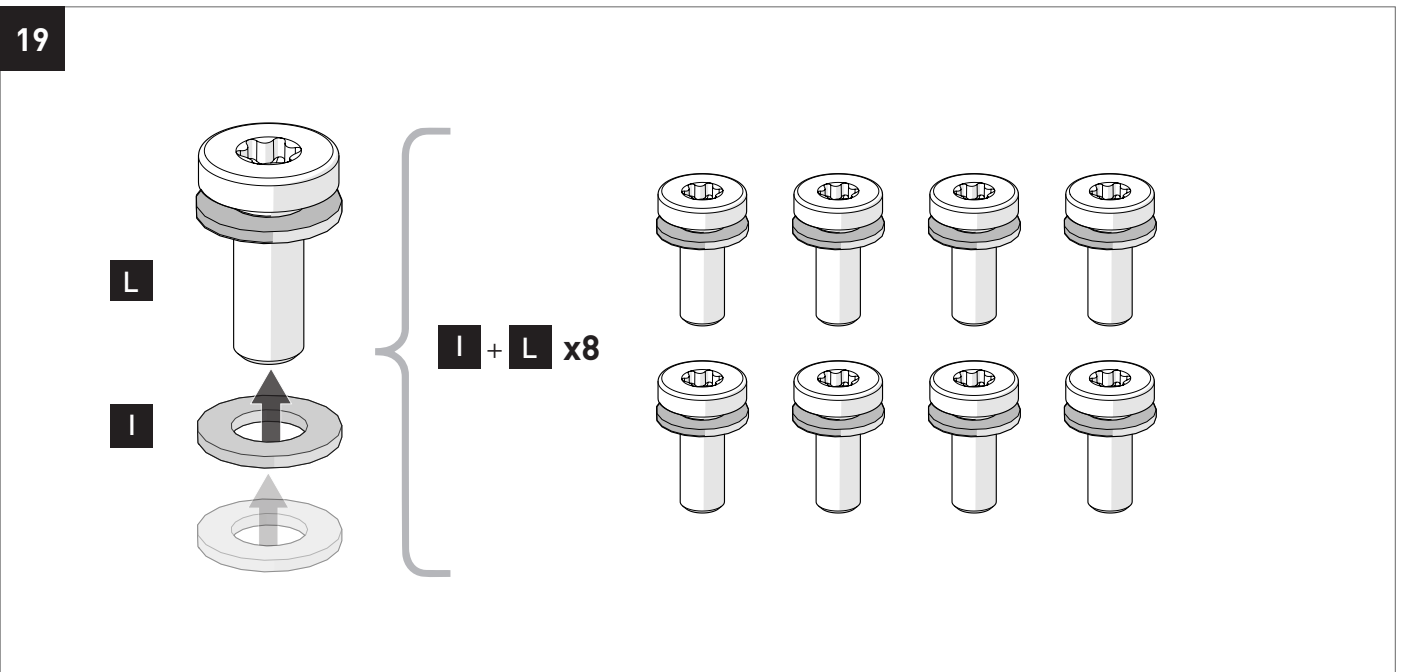
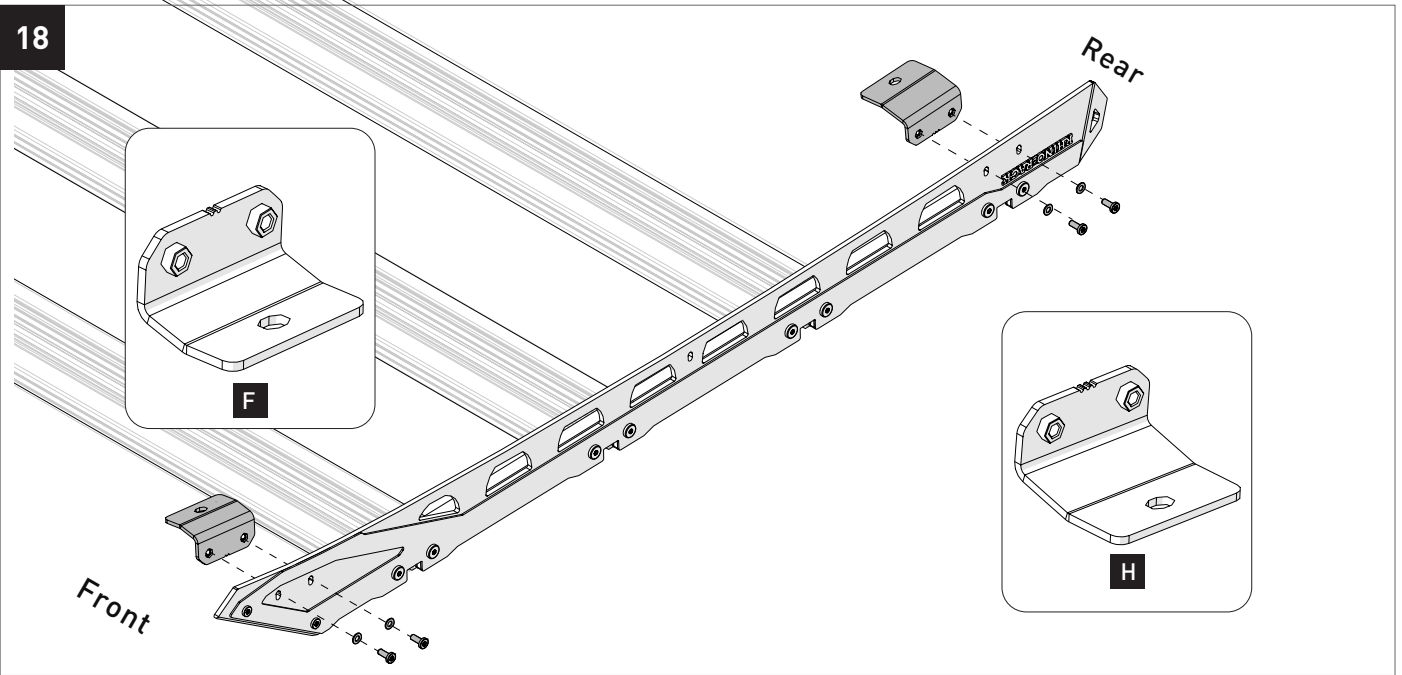

21

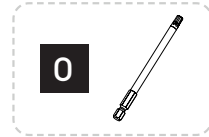
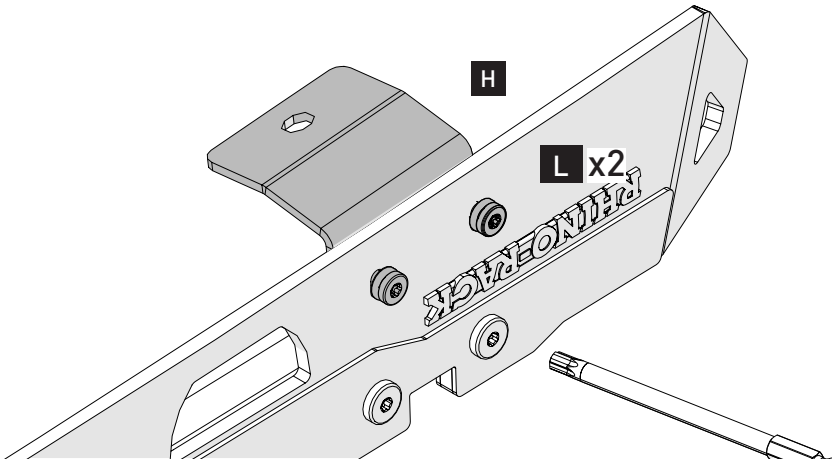

Tighten **L** to



22

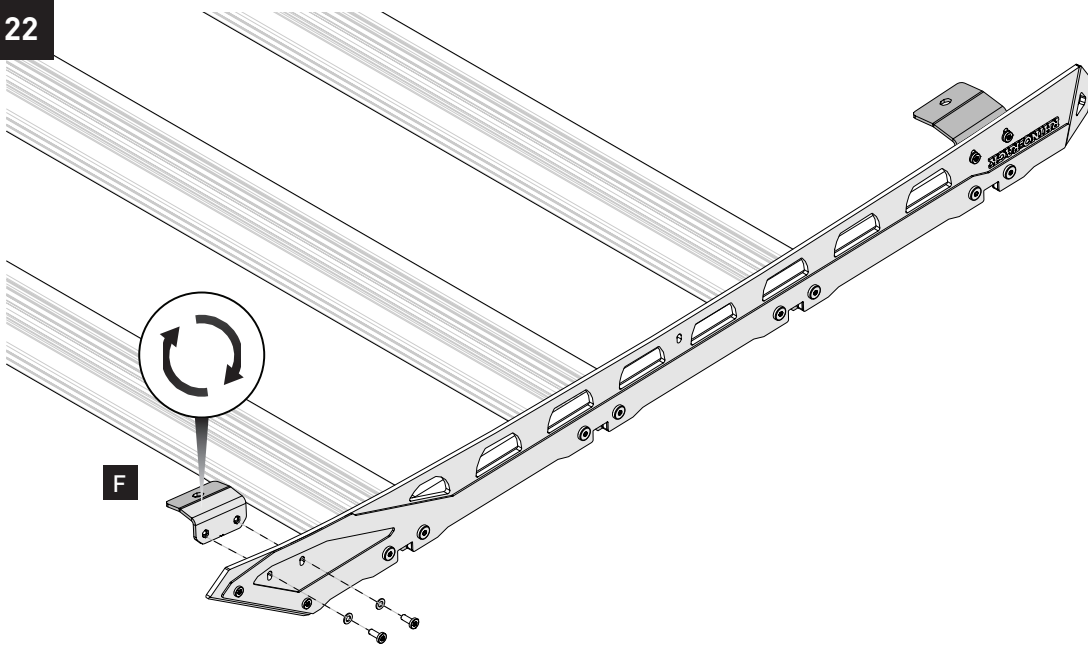

23

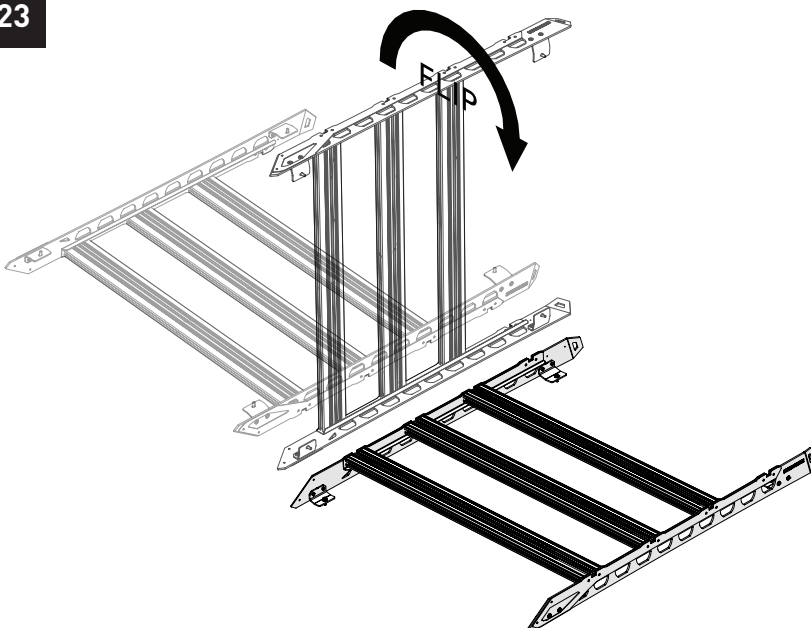

**NOTE**

Upright Rhino-Rack badge indicates the correct orientation.

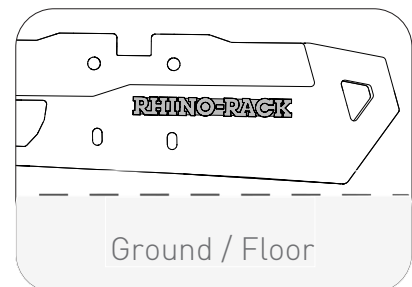

🚩 Assembly Complete. 🚩

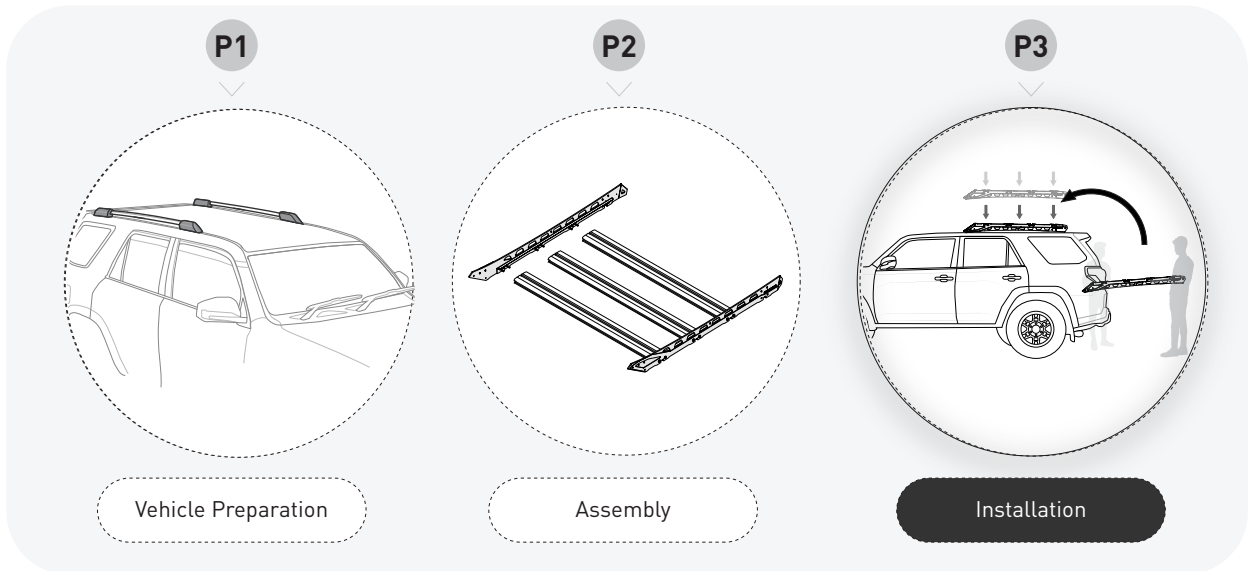

**P3** 24 Lift Reconn platform onto vehicle, carefully placing feet on **Cast Mounting Blocks (D)**.

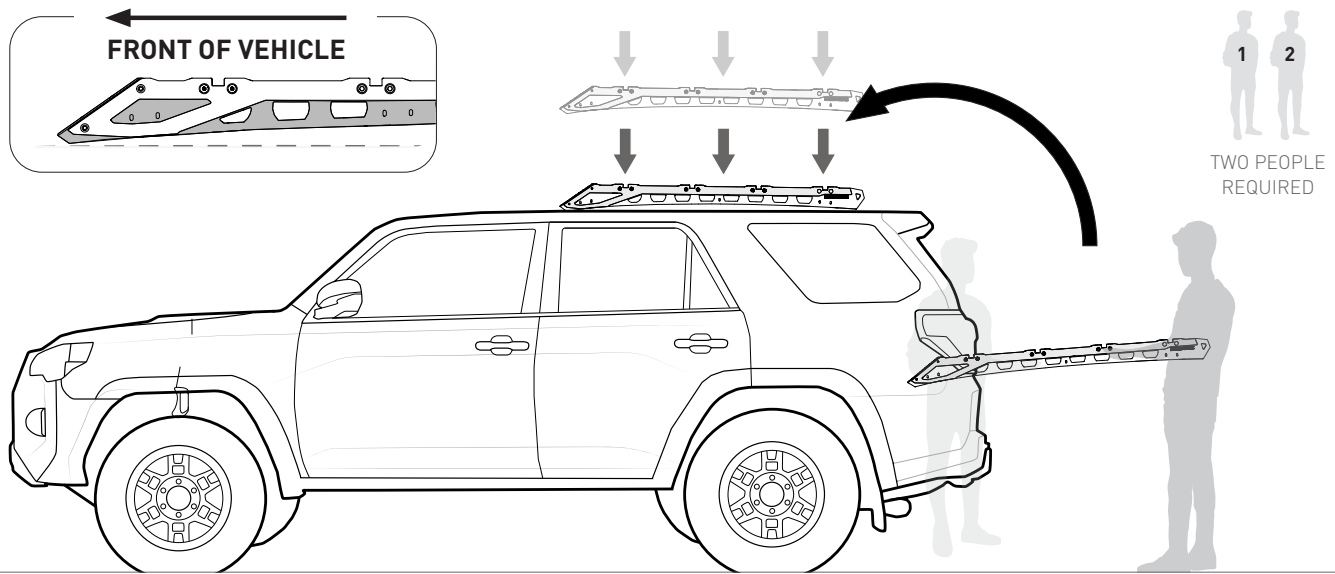

**25**

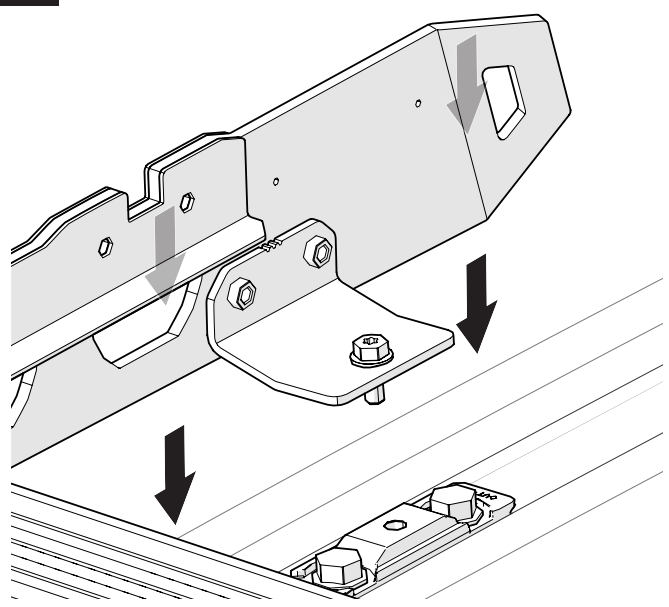

**NOTE**  
**Take Caution** when lowering onto cast mounting blocks to avoid dislodging or shifting out of position.

**26** Align holes in feet to holes in Cast Mounting Blocks.

**Front placement:**

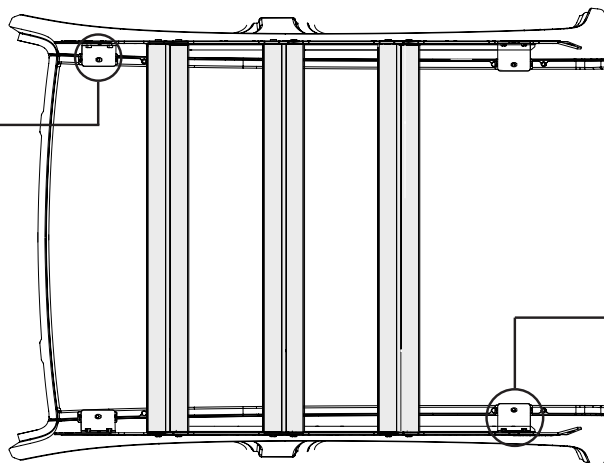

**Rear placement:**

**28** Incrementally tighten all bolts until **15-17Nm** is achieved.

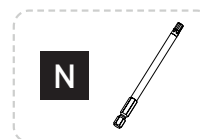
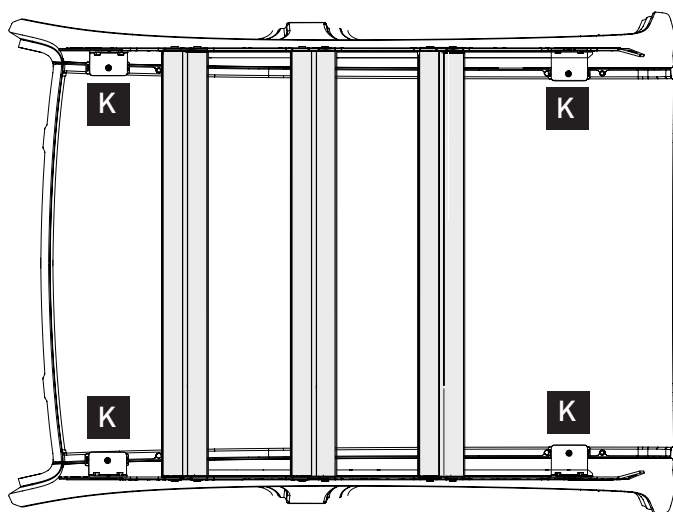

OR

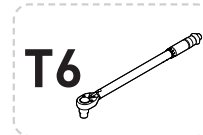

Tighten **K** to



**29**

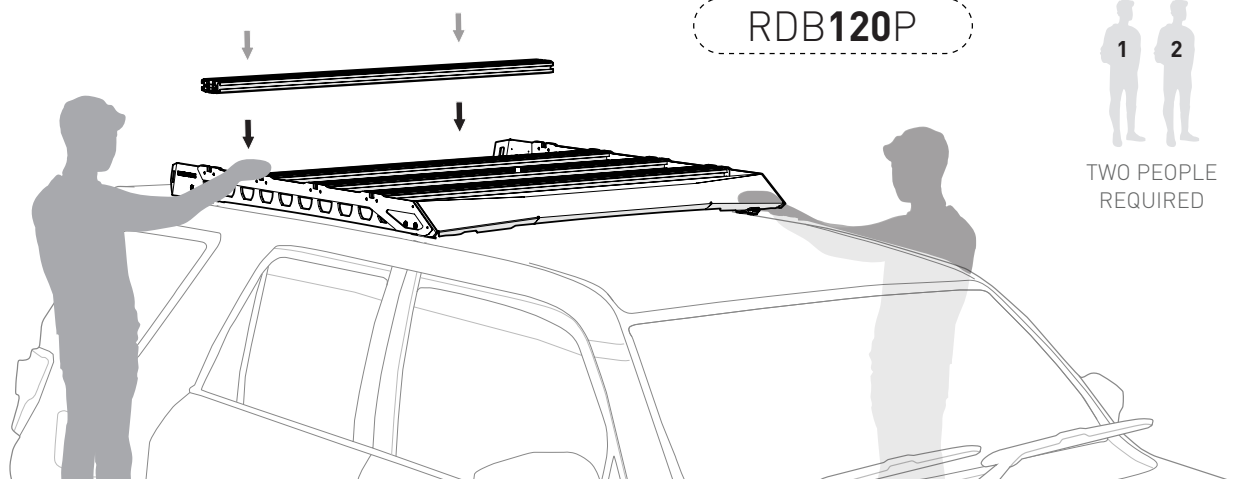

**RDB120P**

**1 2**  
TWO PEOPLE  
REQUIRED

**NOTE**

You may need to loosen **J** & **L** screws for easier alignment during installation.

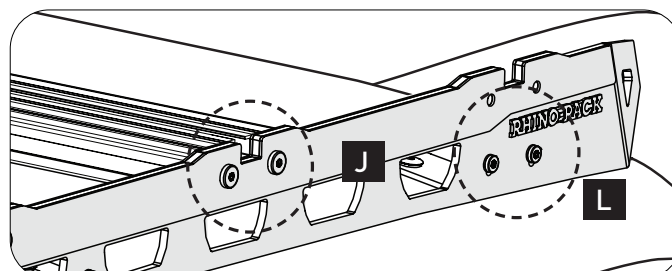

**30** Repeat step on right side.

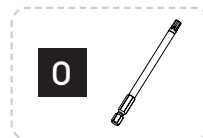
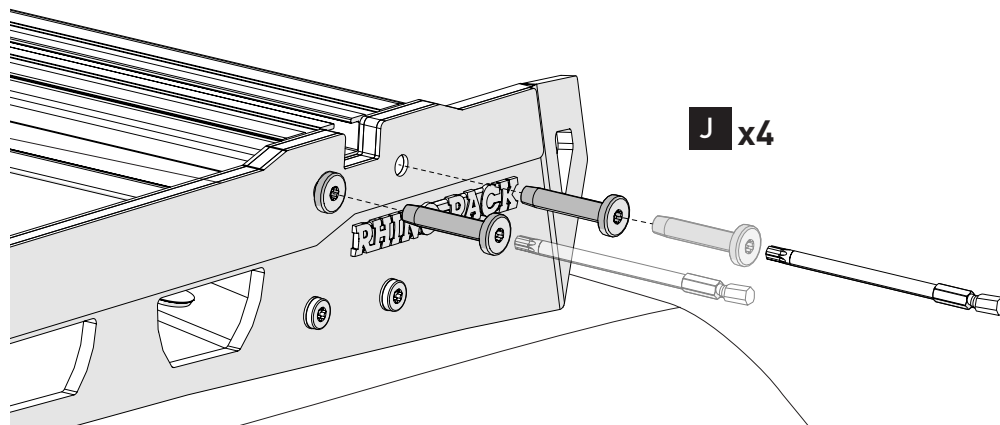

Tighten **J** to



**31**

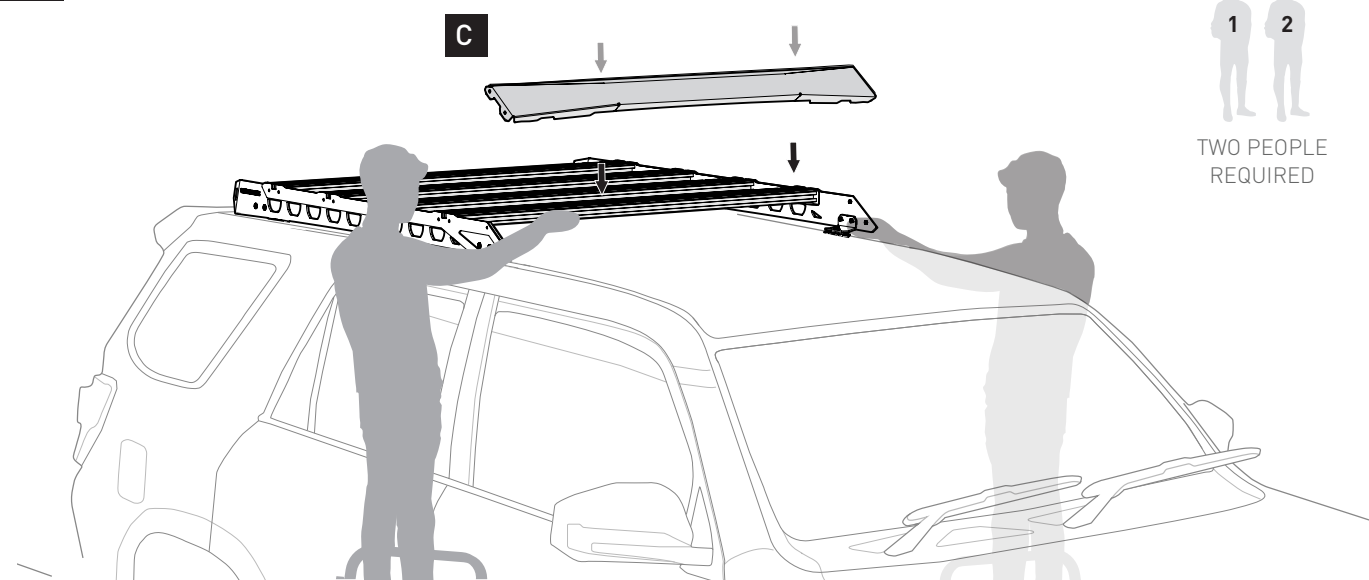

1 2  
TWO PEOPLE  
REQUIRED

**32** Repeat step on right side of Fairing Weldment (**C**) .

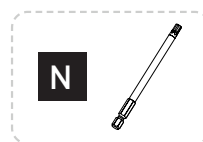
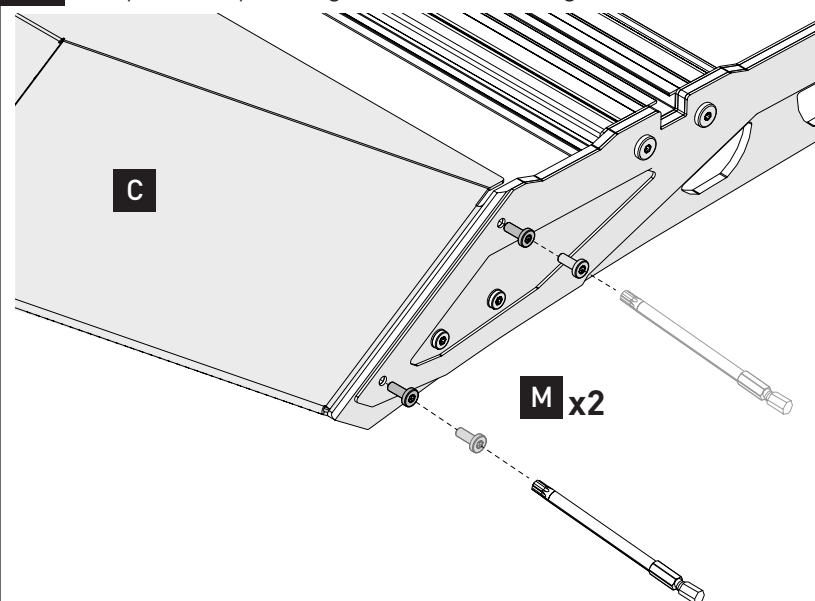

Tighten **M** to



Installation Complete.





**RHINO-RACK®**

MAKE SPACE FOR ADVENTURE

**RHINORACK.COM**

**Rhino-Rack AUSTRALIA**

22A Hanson Pl,  
Eastern Creek, NSW, 2766

**Rhino-Rack USA**

Unit D, 2450 Airport Blvd,  
Aurora, CO, 80011