

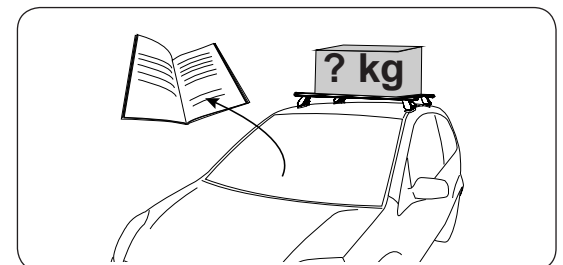

RHINO-RACK

Aerodynamic & Heavy Duty Roof Rack Systems

WARNING!

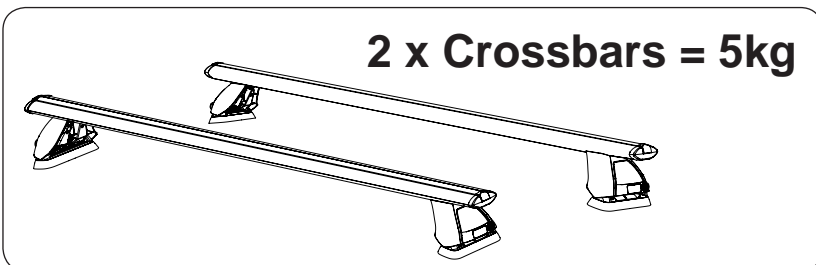
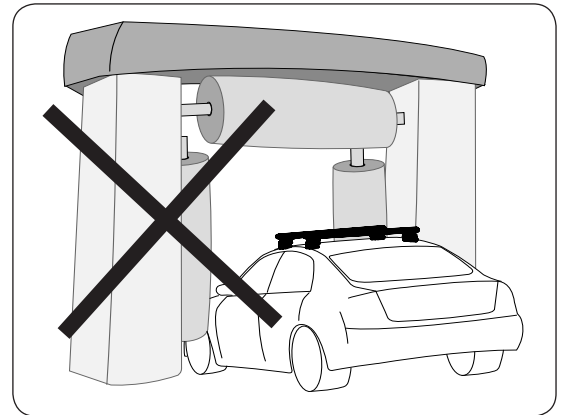
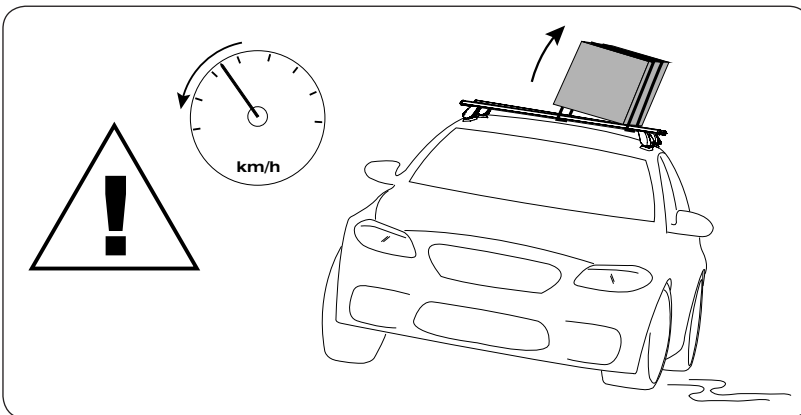
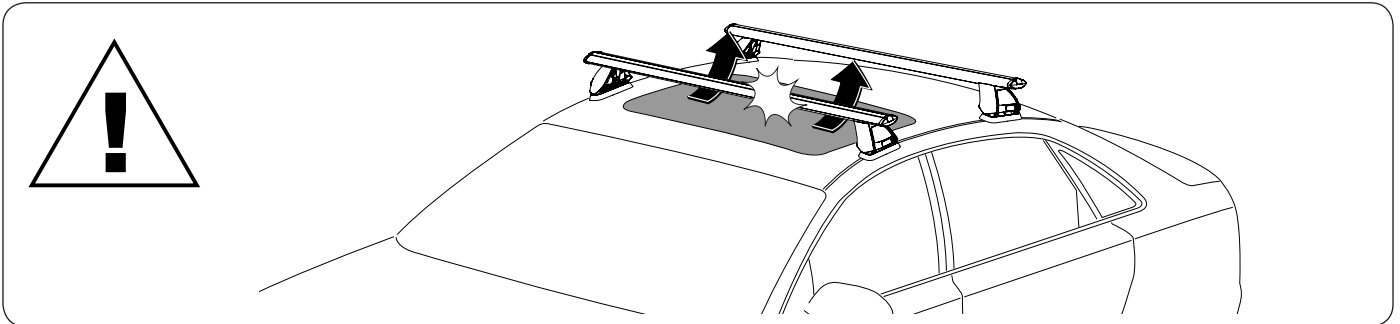
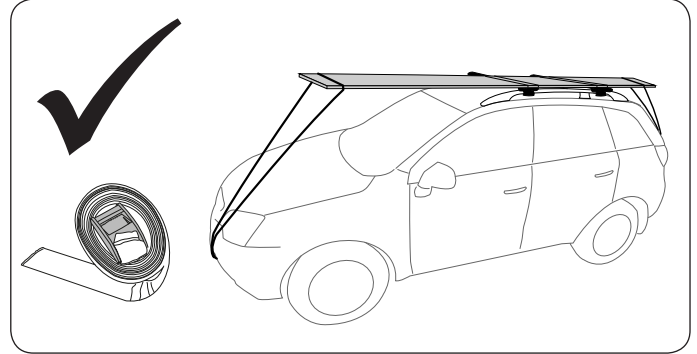
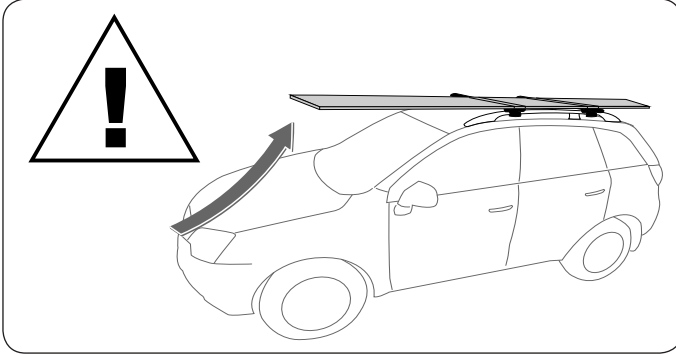

- Please refer to your vehicle manufacturers handbook for maximum roof load capacity.
- Any load transported on Roof Racks must be evenly distributed.
- Instructions are to remain with the vehicle.
- Do not attempt to fit the roof racks to your vehicle unless you fully read and understand the fitting instructions provided.
- Please direct any questions to the dealer from where the roof racks were purchased.



RHINO-RACK

Aerodynamic & Heavy Duty Roof Rack Systems

RL110S12 Leg Kit

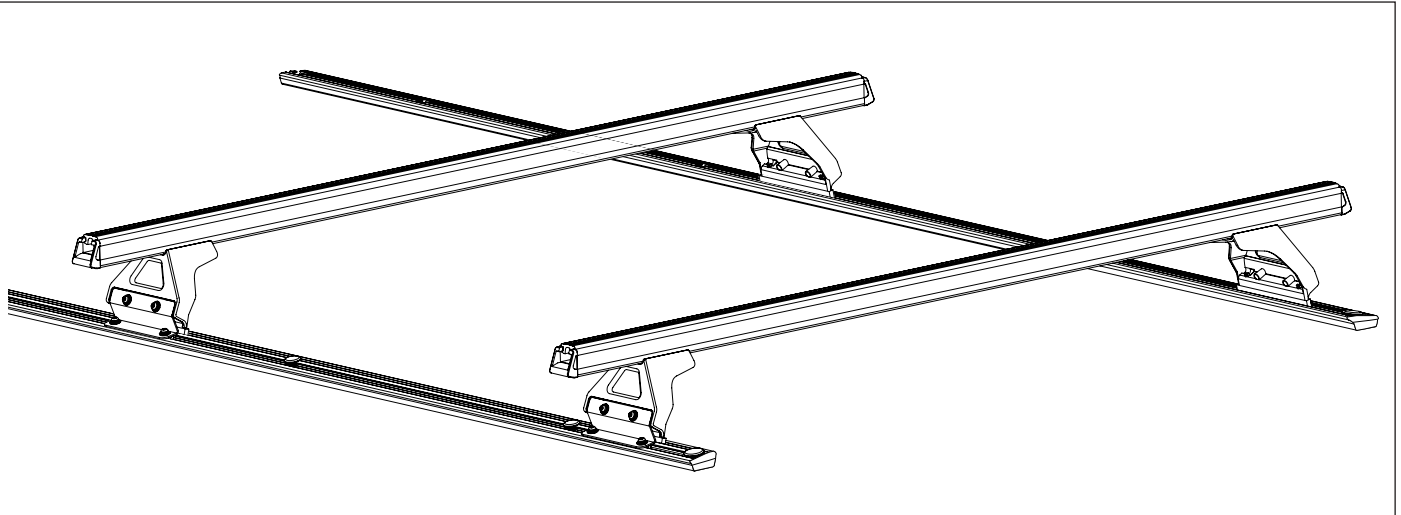

Care Instruction: Wash vehicle roof and track extrusion prior to installation of legs and cross bars.

Important Information

Maximum load capacity: 100kg evenly distributed over crossbars.

Recommendations:

It is essential that all bolt connections be checked after driving a short distance when you first install your crossbars. Bolt connections should be checked again at regular intervals (probably once a week is enough, depending on road conditions, usage, loads and distances travelled). Also check the crossbars each time they are re-fitted. Make sure to fasten your load securely using non-stretch fastening ropes or straps. Please ensure that all loads are evenly distributed and that the centre of gravity is kept as low as possible.

Caution: The handling characteristics of the vehicle changes when you transport a load on the roof. For safety reasons we recommend you exercise extreme care when transporting wind-resistant loads. Special consideration must be taken into account when cornering and braking.

Please remove crossbars when putting vehicle through an automatic car wash.

Load Ratings:

Maximum permissible load is 100kg per pair of crossbars (include the weight of the crossbars, 2 bars = 5kg, 3 bars = 7.5kg). When crossbars are to be used in off-road conditions, please build a safety factor of 1.5 into this load limit. Although the crossbars are tested and approved to AS1235-2000, off-road conditions can be much more rigorous. However, increasing the number of cross bars does not increase the vehicles maximum permissible roof loading.

Note for Dealers and Fitters:

It is your responsibility to ensure instructions are given to the end user or client.

Rhino-Rack
3 Pike Street, Rydalmere,
NSW 2116, Australia.
(Ph) (02) 9638 4744
(Fax) (02) 9638 4822

Document No: RR187
Prepared By: Craig Jones
Authorised By: Chris Murty

Issue No: 03
Issue Date: 15/11/2011

These instructions remain the property of Rhino-Rack Australia Pty. Ltd. and may not be used or changed for any other purpose than intended.



RL110S12 Leg Kit

Parts List

Item	Component Name	Qty	Part No.
1	HD rubber buffer	0	-
2	HD end cap	2	M002
3	HD Crossbar 1500mm	0	-
4	M10 channel nut	2	N024
5	110mm leg	2	M110
6	M6 x 12mm security screw	4	B148
7	M6 spring washer	8	W004
8	M6 x 16mm flat washer	8	W031
9	Track Bracket	2	C548
10	M6 x 27mm security screw	4	B063
11	M10 x 30mm washer	2	W023
12	Rubber boot	2	M053
13	Brass hex nut	4	N009
14	M10 shakeproof washer	2	W021
15	M10 x 25mm hex bolt	2	B071
16	5mm security allen key	1	SecKey-L
17	Fitting instruction	1	RR187

Tools Required:

5mm security allen key, provided in kit Tape measure
 Rubber mallet Side cutters
 16mm or 5/8 Spanner

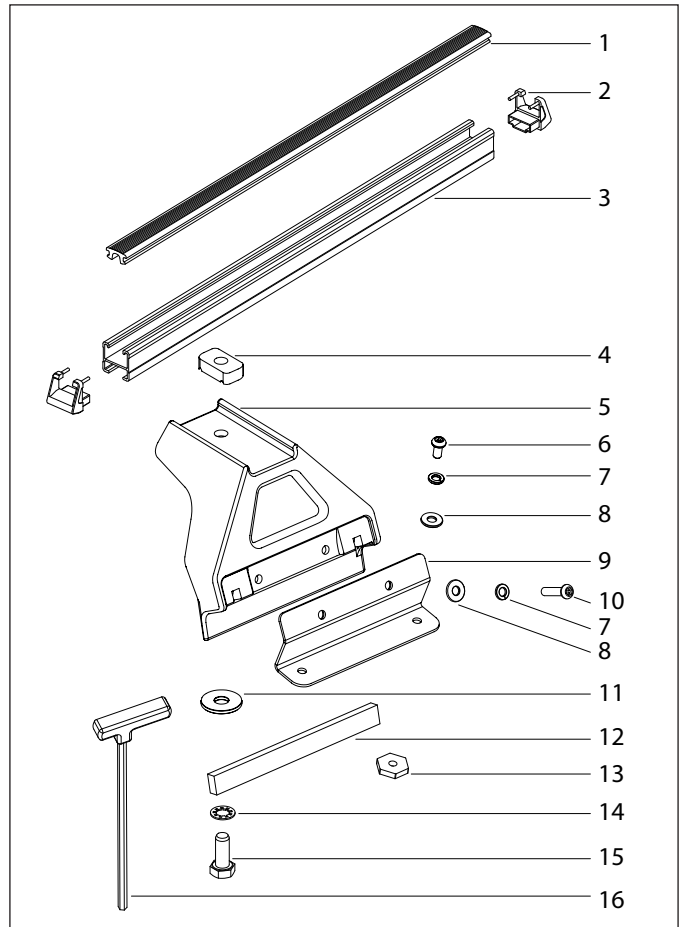

NOTE: Leg height spacers not included in this kit. LHSPAIR and LHS2PAIR available separately.

SWB 3 bar system shown.

To maintain a level height leg across 3 bars leg height spacers are used. Measurements taken from front end of track.

Front, 1 x LHS2PAIR

Middle, 1 x LHSPAIR

Rear, 1 x LHS2PAIR

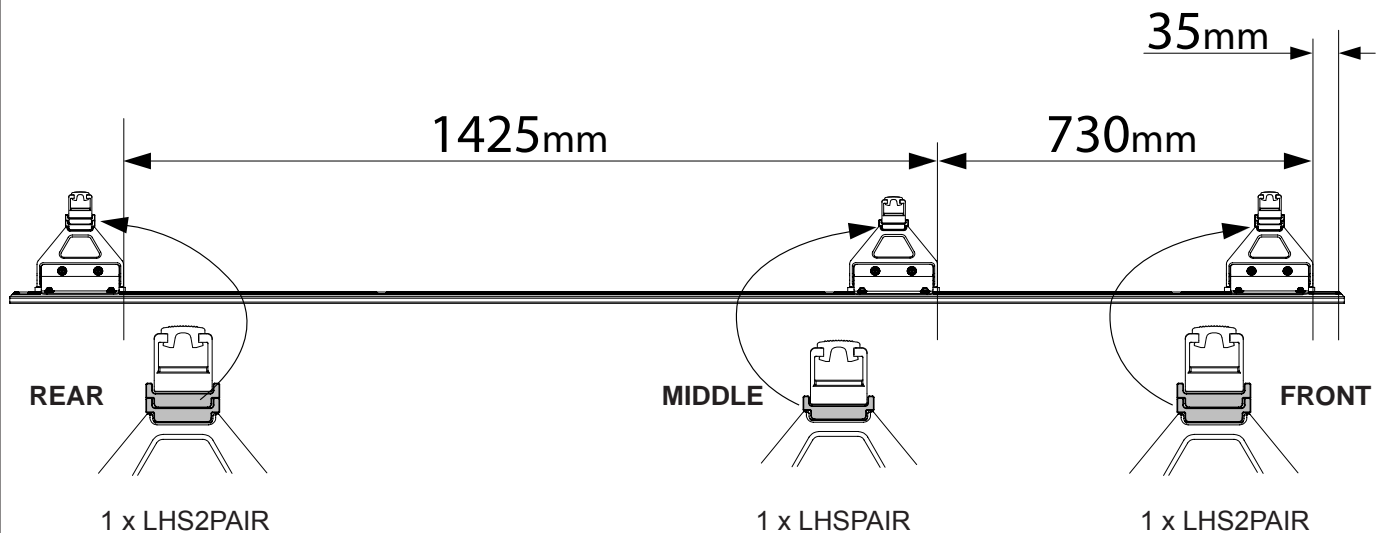



RL110S12 Leg Kit

1 Loosen screws.

- Loosen upper M6 x 27mm screws. Remove lower brass hex nuts and M6 x 12mm screws.
- Fit rubber boot to base of the leg.

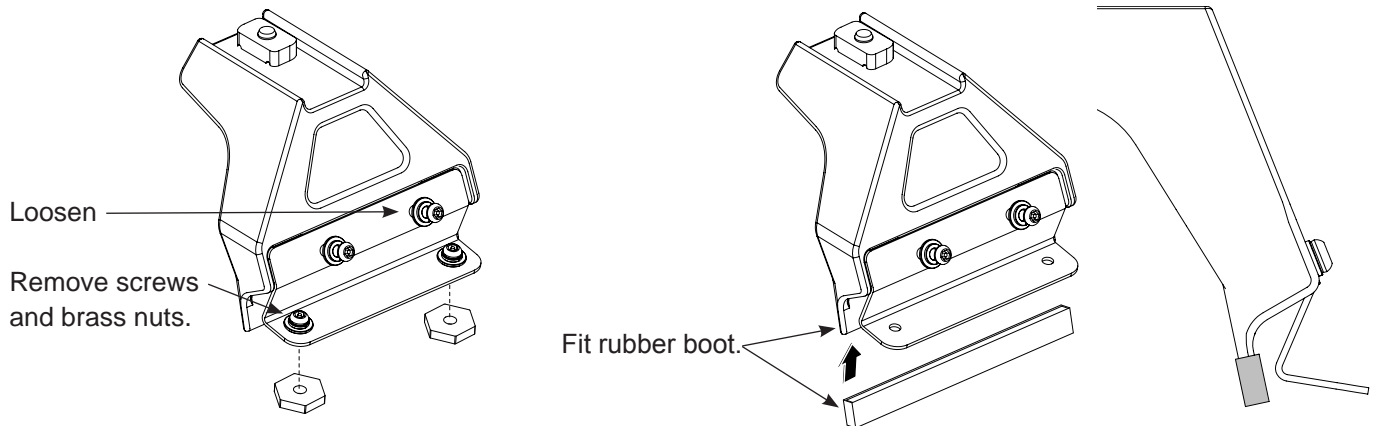

2

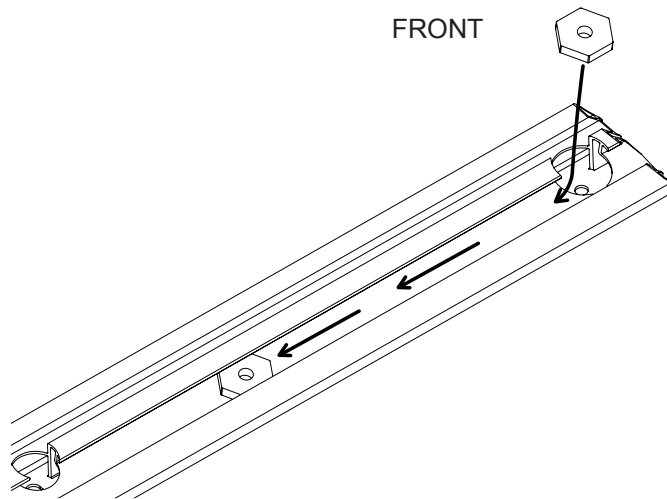

Locate brass hex nuts.

Slide brass hex nuts into track using large cut out at front of the track. Slide close to the final position of the legs as it is very difficult to slide once the brackets are fastened.

Guide for spacing two crossbars, 700mm - 800mm apart.

Three crossbars, refer page 2 for positioning.

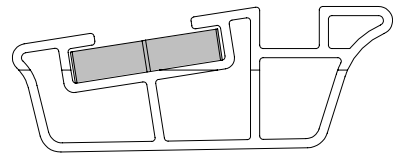

3

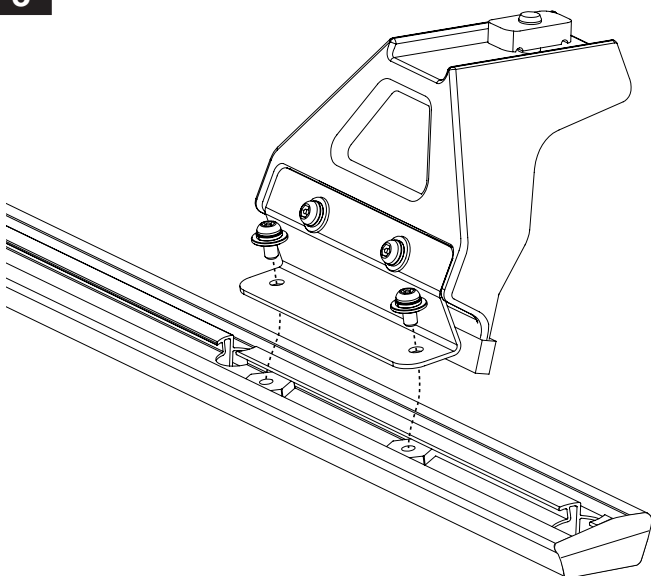

Make sure opposing legs are parallel across vehicle before fastening screws

Fit legs to tracks.

Position leg over brass hex nuts. Locate the rubber boot part of the leg into the inner most slot of the track. Locate the M6 x 12mm screw/washer assembly through holes in the bracket. Finger tighten all four screws of each leg only at this stage.

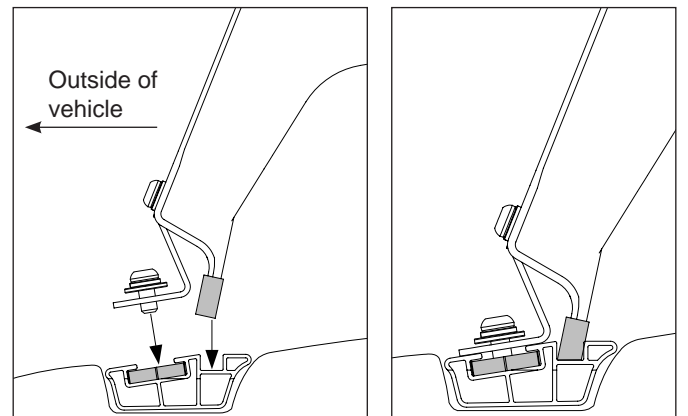



RL110S12 Leg Kit

4

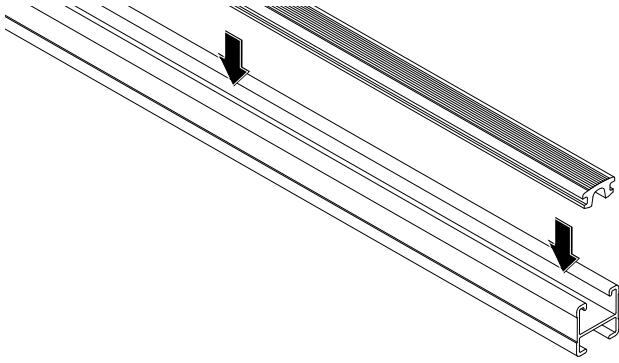

Insert crossbar rubber.

Insert the rubber buffer into top of the crossbar. Trim end of rubber if needed.

5 Fit crossbars.

Place crossbars onto legs. Rotate the M10 bolt so the channel nut is fully located across the bar.

* Refer page 2 for positioning if using three crossbars.

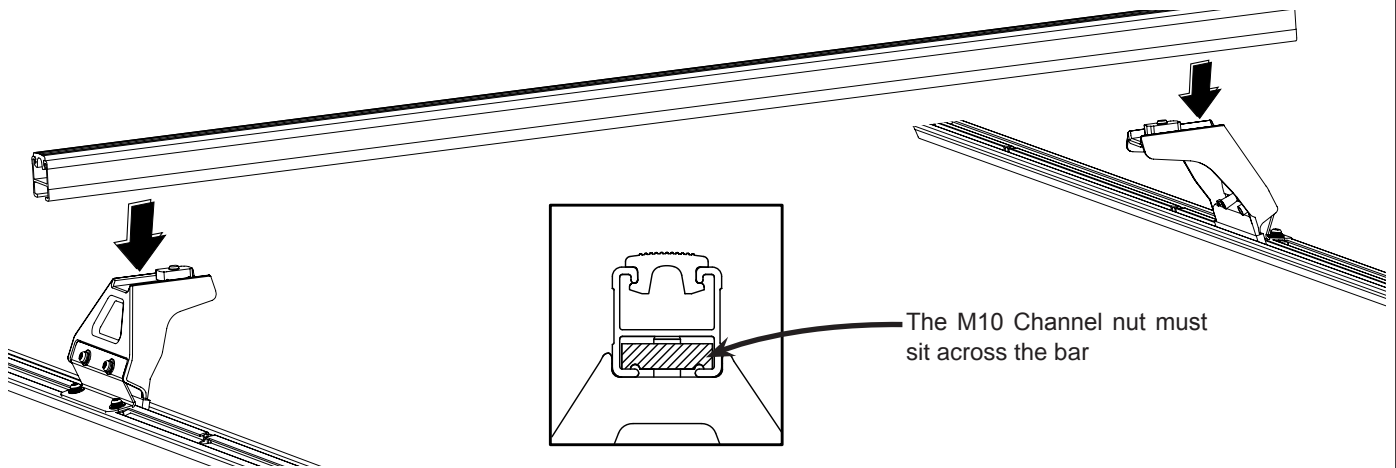

6

c.

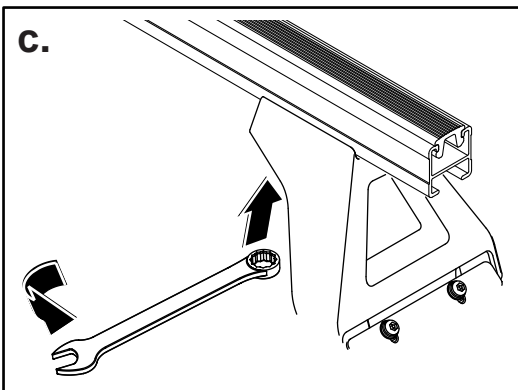

Tighten M10 bolt.

- Measure to make sure the crossbar overhang is equal both sides.
- Check the channel nut is fully located across the bar after tightening.
- Tighten 17-18 Nm (12-13 lb/ft).
DO NOT OVER TIGHTEN.

M10 Channel nut must sit across the bar when tight

b.

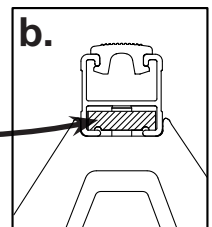

a.

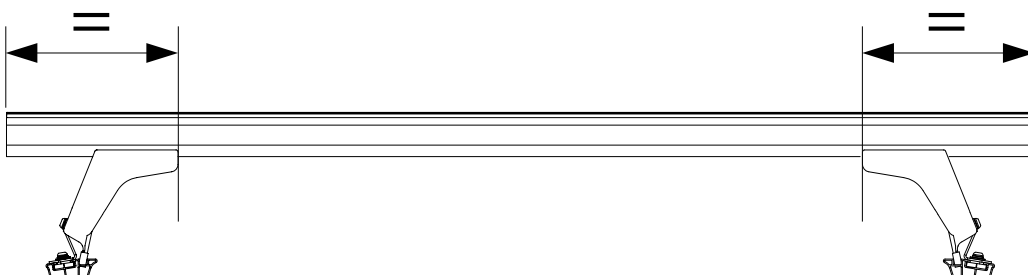



RL110S12 Leg Kit

7 Tighten M6 screws.

Progressively and evenly tighten the upper and lower clamp screws to secure the leg and clamp to the track. Tighten M6 screws to 3-4 Nm (2-3 lb/ft).

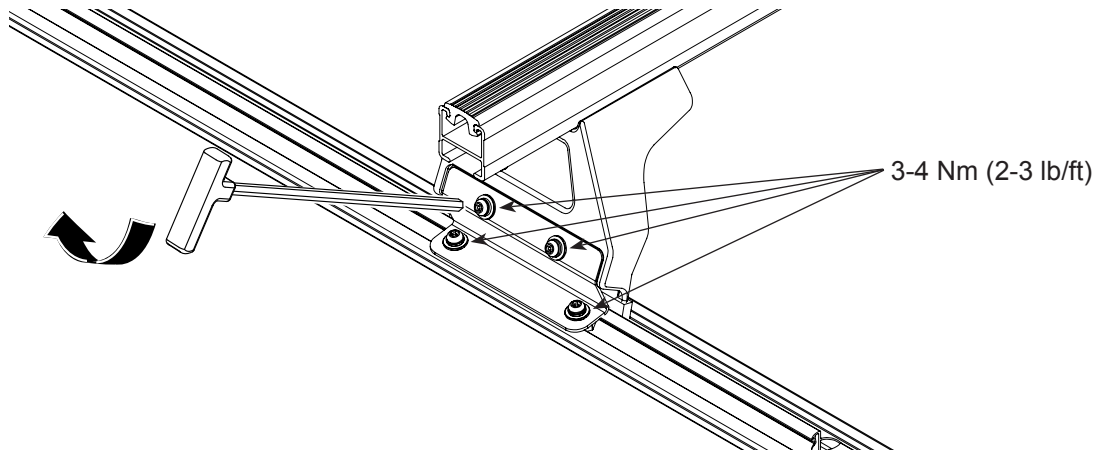

8

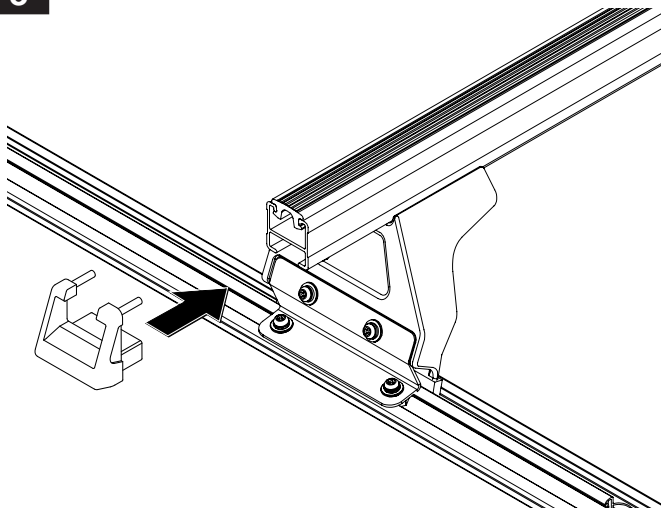

End caps.

Insert end caps into end of crossbars. A rubber mallet may be needed to knock them in. Check all attachment bolts and screws after fitment.

NOTE: Fit legs and cross bars before inserting plastic track plugs.

9 Plug exposed track holes. (Plugs included with track kit)

If the legs do not cover the large clearance holes in the tracks insert the supplied plastic track plugs. Use two large plugs C563 at the rear. A rubber mallet may be used to knock the caps in. 12 plugs are included you may not need to use them all.

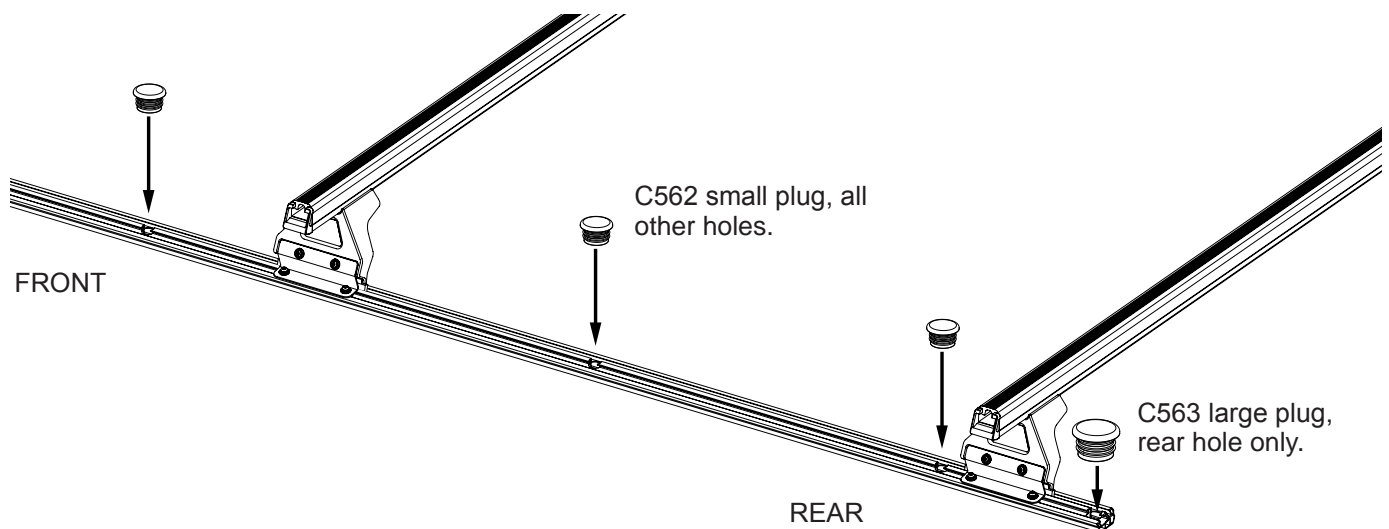



RHINO-RACK

Aerodynamic & Heavy Duty Roof Rack Systems

RTS513 VW T5 Transporter SWB - Rhino Track Mount

Important: Please read these instructions carefully prior to installation.
Please refer to your fitting instruction to ensure that the roof racks are installed in the correct locations.
Check the contents of kit before commencing fitment and report any discrepancies.
Place these instructions in the vehicle's glove box after installation is complete.

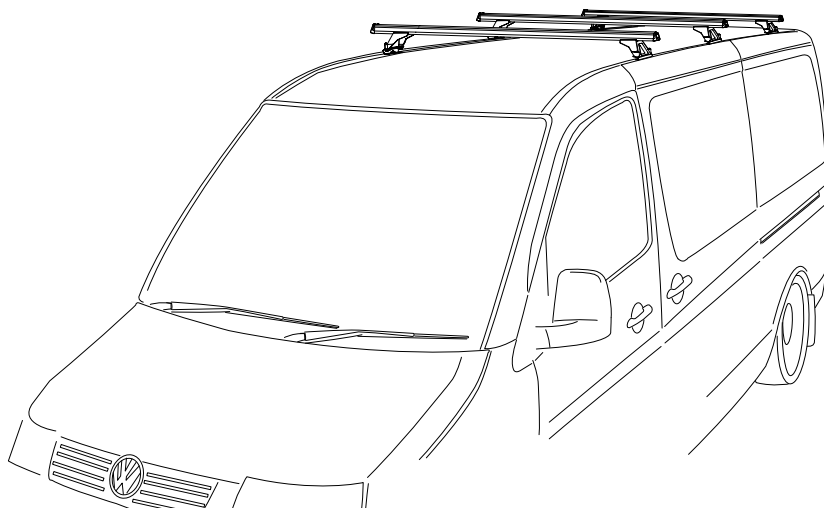

Care Instruction: Wash vehicle roof especially the mounting points prior to installation.

Note: See page 4 for fitting of plugs before installing legs and cross bars.

Important Information

Maximum carrying capacity: 100kg

Recommendations:

It is essential that all bolt connections be checked after driving a short distance when you first install your cross bars. Bolt connections should be checked again at regular intervals (probably once a week is enough, depending on road conditions, usage, loads and distances travelled). You should also check the cross bars each time they are re-fitted.

Make sure to fasten your load securely. Please ensure that all loads are evenly distributed and that the centre of gravity is kept as low as possible.

Use only non-stretch fastening ropes or straps.

Sensitivity to cross winds, behaviour in curves and braking.

The handling characteristics of the vehicle, changes when you transport a load on the roof. For safety reasons, we recommend you exercise extreme care when transporting wind-resisting loads; special consideration must be taken into account when braking.

Please remove cross bars when putting vehicle through an automatic car wash.

Load Ratings:

Maximum permissible load is 100kg per pair of cross bars (include the weight of the cross bars, 5kg). When cross bars are to be used in off-road conditions, please build a safety factor of 1.5 into this load limit. Although the cross bars are tested and approved to AS1235-2000, Australian road conditions can be much more rigorous. However, increasing the number of cross bars does not increase the vehicles maximum permissible roof loading.

Note for Dealers and Fitters:

It is your responsibility to ensure instructions are given to the end user or client.

Rhino-Rack
3 Pike Street, Rydalmere,
NSW 2116, Australia.
(Ph) (02) 9638 4744
(Fax) (02) 9638 4822

Document No: RR-163
Prepared By: Craig Jones
Authorised By: Gary England

Issue No: 02
Issue Date: 04/09/2008

These instructions remain the property of Rhino-Rack Australia Pty. Ltd. and may not be used or changed for any other purpose than intended.



RTS513 VW T5 Transporter SWB - Rhino Track Mount

Parts List

Item	Component Name	Qty	Part No.
1	Track End Cap Rear RIGHT	1	C496
2	Track End Cap Rear LEFT	1	C495
3	Track LEFT & RIGHT 2385mm	pair	A343
4	Track End Cap Front RIGHT	1	C520
5	Track End Cap Front LEFT	1	C519
6	M6 x 16mm Security Screw	8	B061
7	M6 Spring Washer	8	W004
8	M6 x 12.5mm Flat Washer	8	W003
9	5mm Rivet	2	H008
10	5mm Security Allen Key	1	H021
11	Plastic Track Plug	8	C562
12	Plastic Track Plug	2	C563
13	Fitting Instruction	1	RR-163

Tools Required:

5mm Security Allen key,
provided in kit.
Cold Galvanising solution.
Silastic Sealant.
Rubber Mallet.

Pneumatic or Concertina
rivet gun.
Drill & 5mm drill bit.
Vacuum Cleaner.
Caulking Gun.

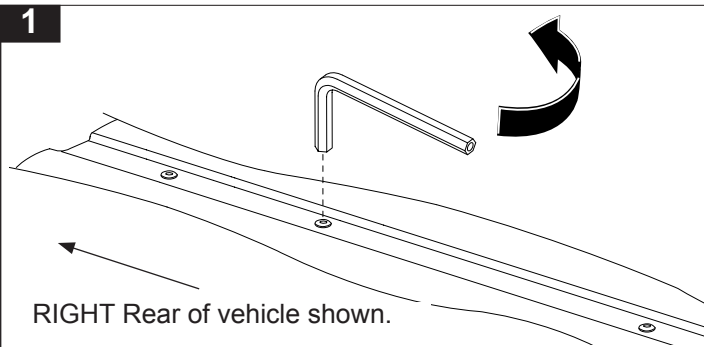
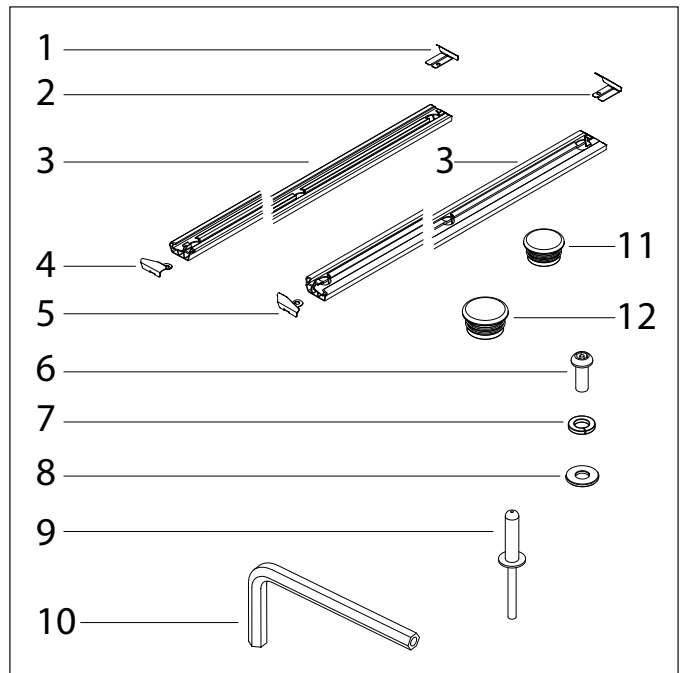

Using the 5mm allen key supplied remove all 8 screws in the roof channel.

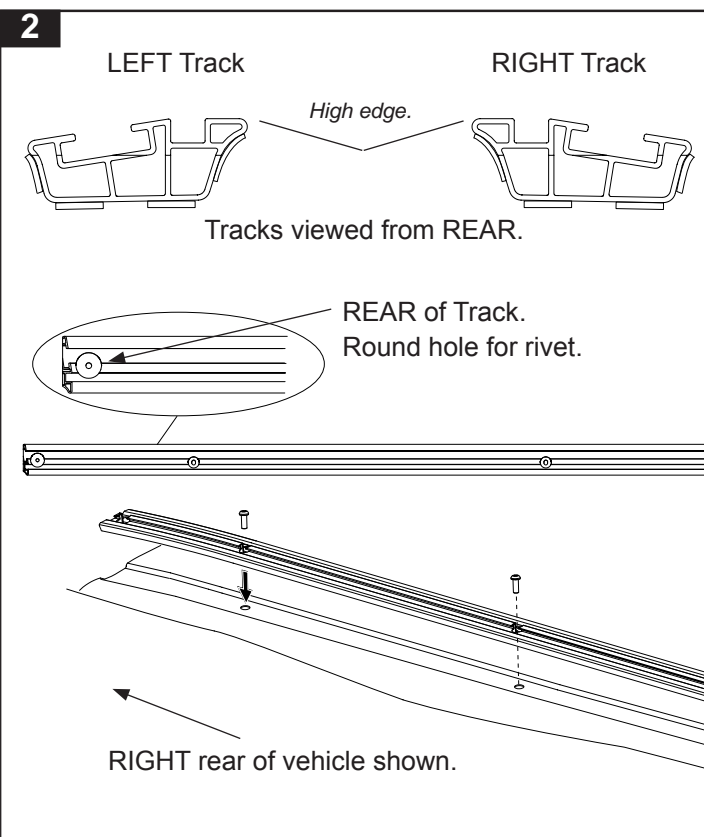

Tracks are Left and Right handed. The small bend in the track is at the rear. Lay the track over the holes and use at least two M6 x 16mm screws to locate track. The higher edge of each track face each other when installed.



RTS513 VW T5 Transporter SWB - Rhino Track Mount

3

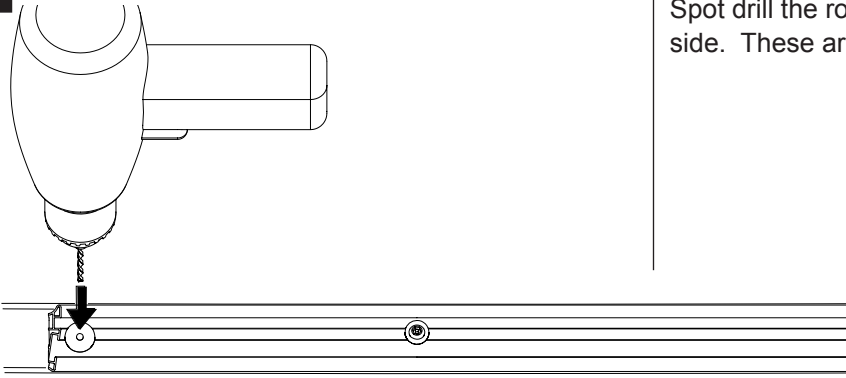

Spot drill the roof channel to mark the end hole on each side. These are to be riveted.

4

Remove the screws and track. Drill through the roof in one spot each side. Use a vacuum cleaner to remove swarf from the roof. This will minimise swarf entering the hole and avoid scratching. Wipe after with a rag.

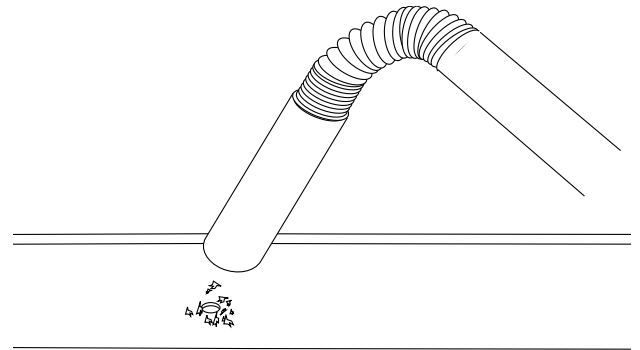
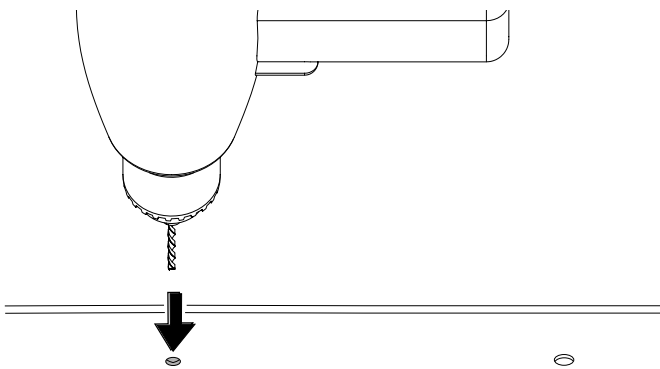

5

STEP 1.

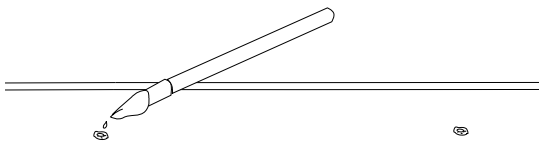

STEP 1. Apply a liberal amount of cold galvanizing solution to the inside and surrounds of the drilled holes only. Allow cold galvanizing solution to touch dry, ten minutes or so.

STEP 2.

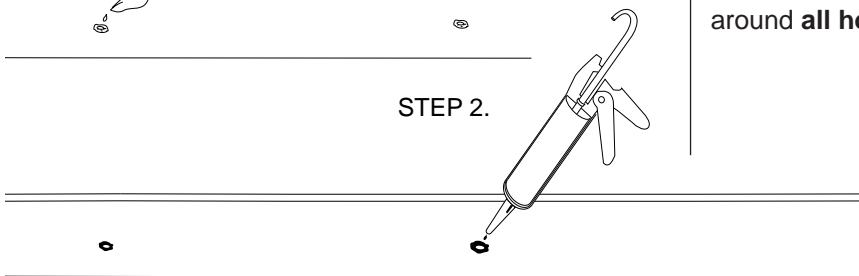

STEP 2. Apply a liberal amount of Silastic sealer in and around **all holes** to prevent water leaks.

6

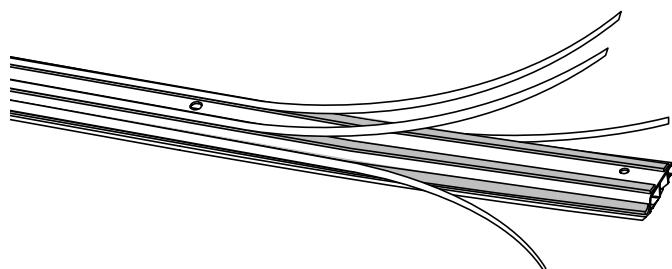

Peel the four white backing strips off the foam tape on each track.



RTS513 VW T5 Transporter SWB - Rhino Track Mount

7 The tongue on both front and rear end caps sit inside the track ends. The rear end cap slides straight in. The front end cap needs to be rotated and fed in. Rear end cap is held in with the rivet. Front end cap is held in with a screw. **IMPORTANT:** End caps must be in place before tracks are riveted.

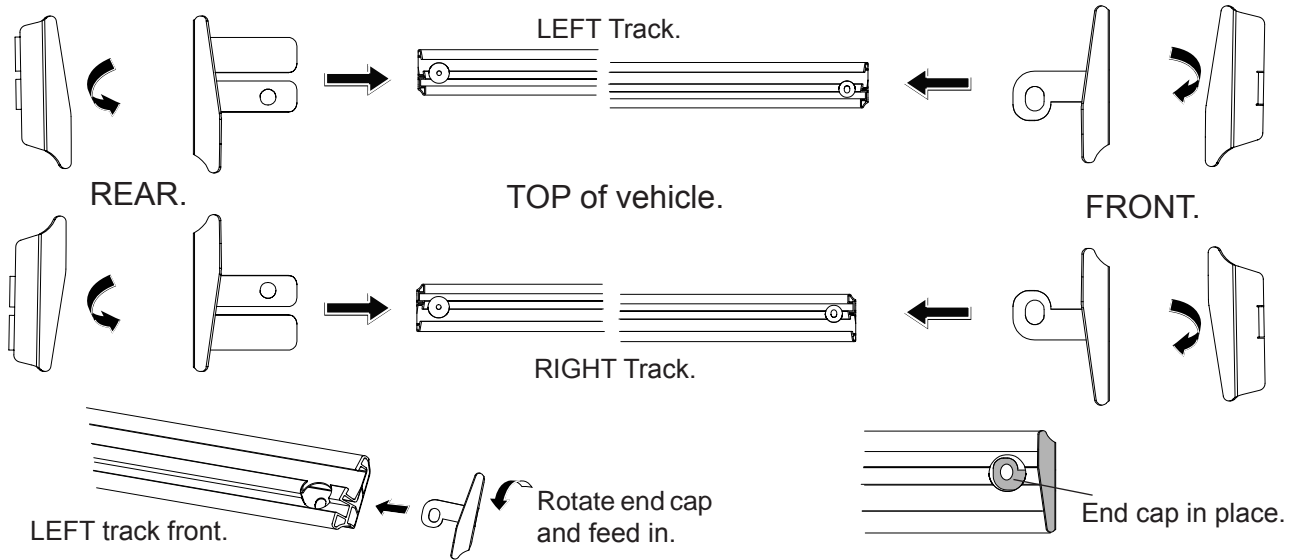

8 Place the track on and check that all holes line up. Fasten the screws to pull the track in place. Secure the rivet in place.



NOTE: Fit required legs and cross bars before inserting plastic track plugs.

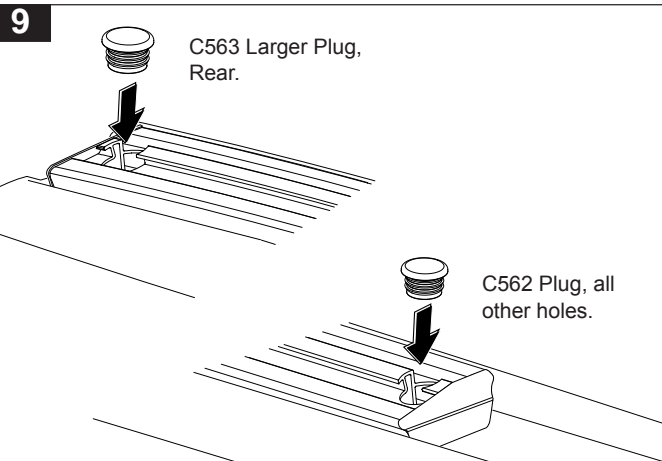

Install and position roof racks as required.

If the legs do not cover the large clearance holes in the track insert the supplied plastic track plugs. The two larger plugs C563 are to cover the rear rivets. A rubber mallet may be needed to knock the caps all the way down. 10 plugs are included you may not need to use them all.