

## WARNING! Important Load Carrying Instructions

With utility vehicles, the cabin and the canopy move independently. Roof racks and vehicle can be damaged if the item transported is rigidly fixed at points on both the cabin and canopy. Instead, rigidly fix to either the cabin roof racks or the canopy roof racks.

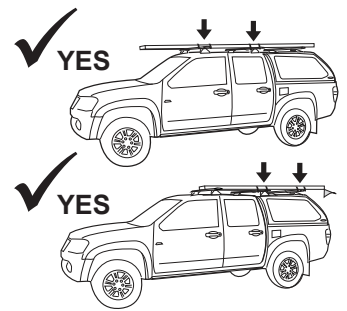
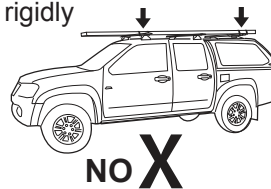

- Any load transported on Roof Racks must be evenly distributed.
- Instructions are to remain with the vehicle.
- Do not attempt to fit the roof racks to your vehicle unless you fully read and understand the fitting instructions provided.
- Please direct any questions to the dealer from where the roof racks were purchased.
- Check the contents of this kit before commencing fitment and report any discrepancies.

**Maximum load capacity: 50kg/110lbs - 100kg/220lbs.** Please refer to your vehicle manufacturers handbook for maximum roof load capacity, always use the lower of the two figures.

### Recommendations:

It is essential that all bolt connections be checked after driving a short distance when you first install your crossbars. Bolt connections should be checked and lubricated at regular intervals (probably once a week is enough, depending on road conditions, usage, loads and distances travelled). You should also check the crossbars each time they are refitted. Make sure to fasten your load securely. Please ensure that all loads are evenly distributed and that the centre of gravity is kept as low as possible.

**Crossbars must be removed when putting vehicle through an automatic car wash.**

**Use only non-stretch fastening ropes or straps.**

**Caution:** The handling characteristics of the vehicle changes when you transport a load on the roof. For safety reasons we recommend you exercise extreme care when transporting wind-resistant loads. Special consideration must be taken into account when cornering and braking.

### Off-road Load Rating:

When crossbars are to be used in off-road conditions, please build a safety factor of 1.5 into this load limit for off-road use, two crossbars = **33kg/73lbs - 66kg/145lbs**. Although the crossbars are tested and approved to AS1235-2000, off-road conditions can be much more rigorous. However, increasing the number of crossbars does not increase the vehicles maximum permissible roof loading.

### Note for Dealers and Fitters:

It is your responsibility to ensure instructions are given to the end user or client.

Rhino-Rack  
3 Pike Street, Rydalmere,  
NSW 2116, Australia.  
(Ph) (02) 9638 4744  
(Fax) (02) 9638 4822

Document No: R352  
Prepared By: Kayle Everett  
Authorised By: Chris Murty

Issue No: 01  
Issue Date: 6/12/2013

These instructions remain the property of Rhino-Rack Australia Pty. Ltd. and may not be used or changed for any other purpose than intended.



# RHINO-RACK

**SX002**

Place these instructions in the vehicle's glove box after installation is complete.

**Important:** Please read these instructions carefully prior to installation. Please refer to your fitting instruction to ensure that the roof racks are installed in the correct locations. Check the contents of kit before commencing fitment and report any discrepancies.

Item	Component Name	Qty	Qty	Part No.
		SX002H	SX002	
1	Vortex Generating Strip	1-2	2-4	M626
2	Crossbar	1	2	VA---
3	Crossbar Under bar Strip	2	4	M641
4a	End Cap	2	4	M645
4b*	End Cap (Locking)	2	4	VA-LEC4
4c*	Lock Barrel Key	2	3	CA1069
5A	SX Leg Right	1	2	SXBOUT-RIGHT
5B	SX Leg Left	1	2	SXBOUT-LEFT
6	Torque Security Key For SXB	1	1	TORKEY-SXB
7	Fitting Instruction	1	1	R352

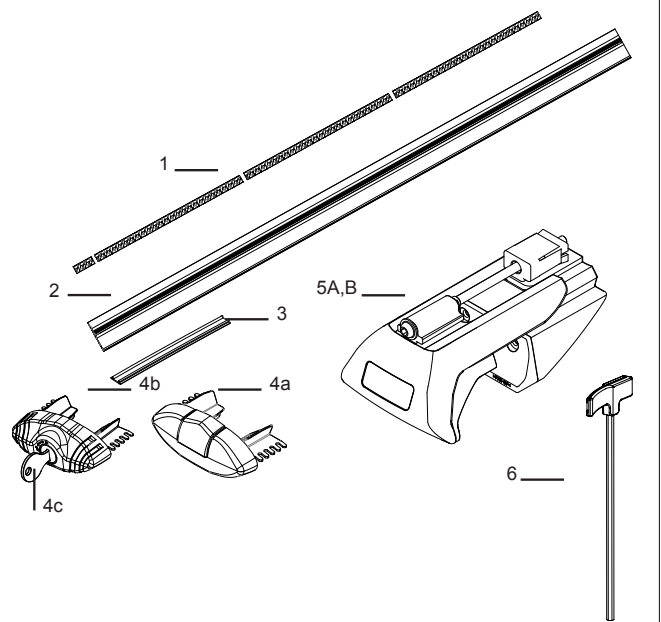

**Items 1-4 SOLD SEPARATELY**

**Care Instruction:**

Wash and clean vehicle roof rails prior to fitting th roof racks.

**\* Optional extras**

**Tools:** \*Optional Extra

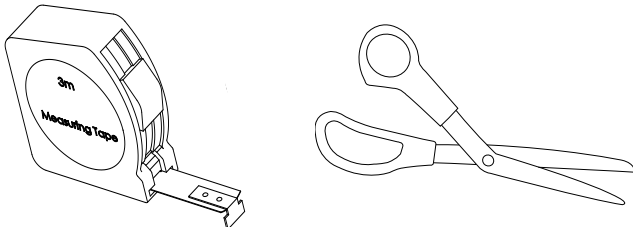

**1** Each crossbar must have a left and right hand leg fitted, the legs are identified with left and right on the outer leg clamp moulding as shown below. **The arrow must point to the front of the vehicle when the crossbars are fitted.**

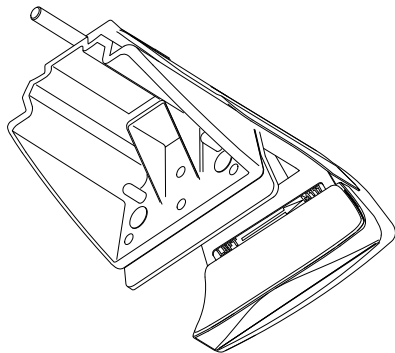

**2** Slide the leg assembly into both ends of the crossbar.

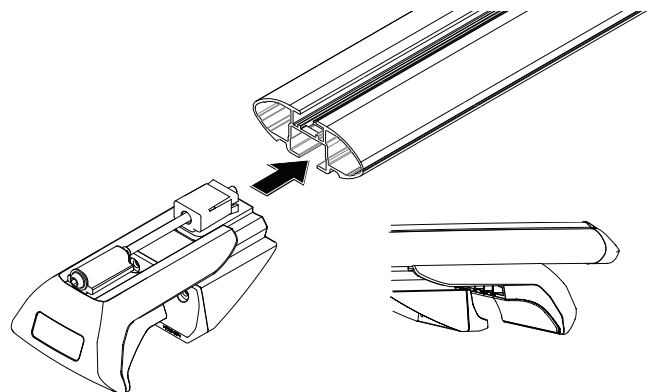

# SX002

**3** NOTE: Fitting instructions here shown with the SX100 legs.

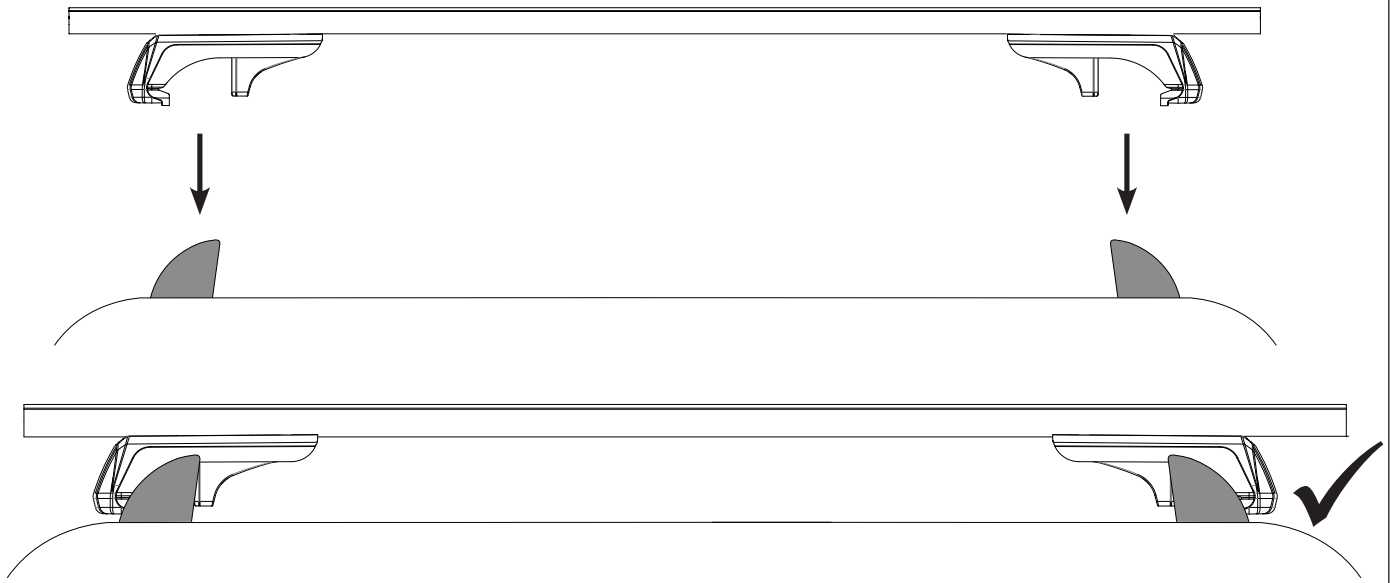

**4** 700-800mm  
(27,9/16"-31,1/2")

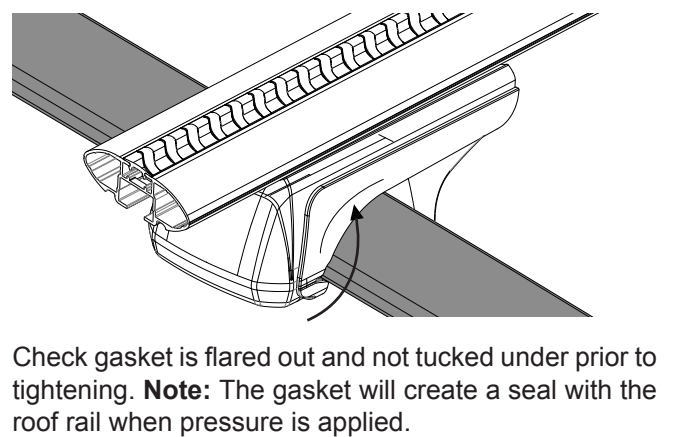
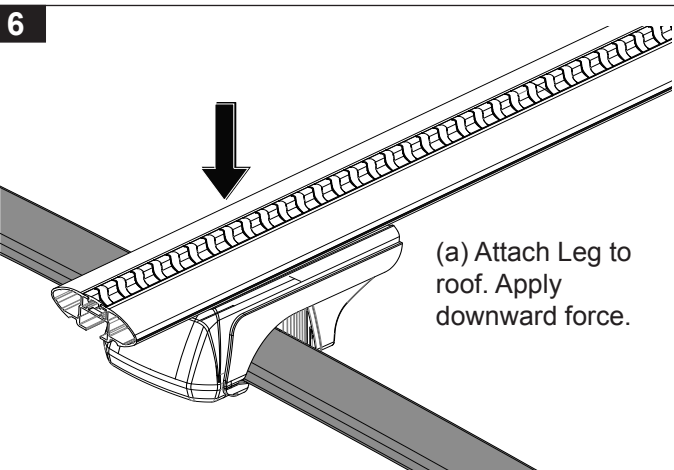
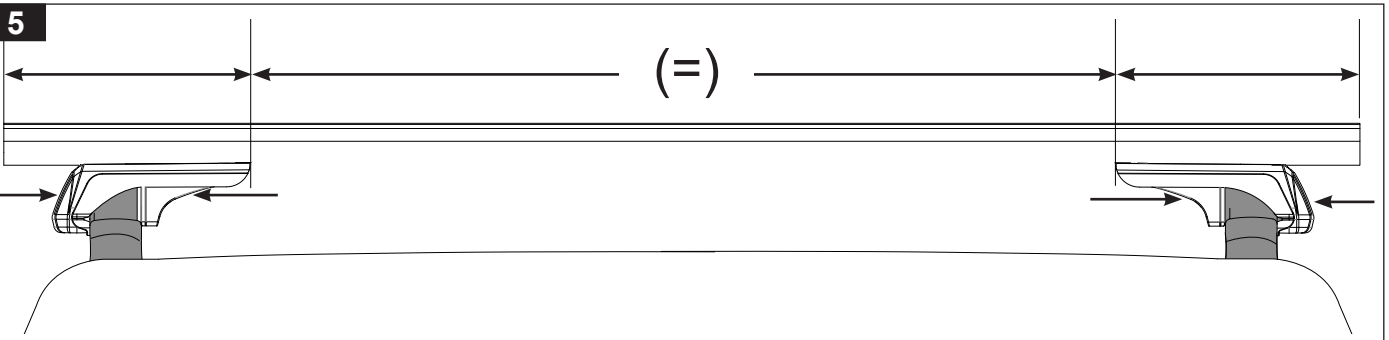
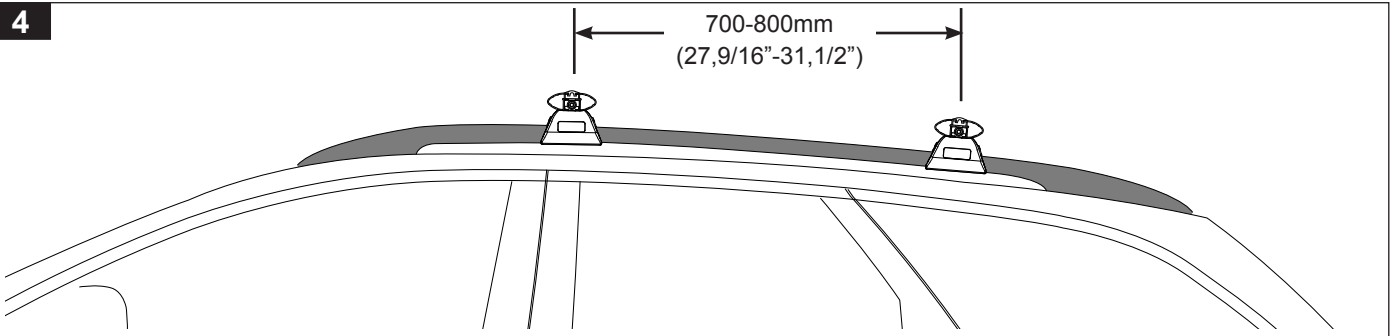

# SX002

7a

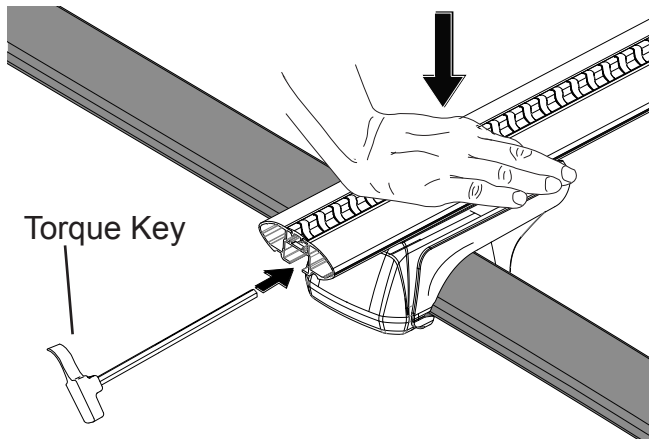

Fasten each leg alternately using the supplied Torque allen key.

7b

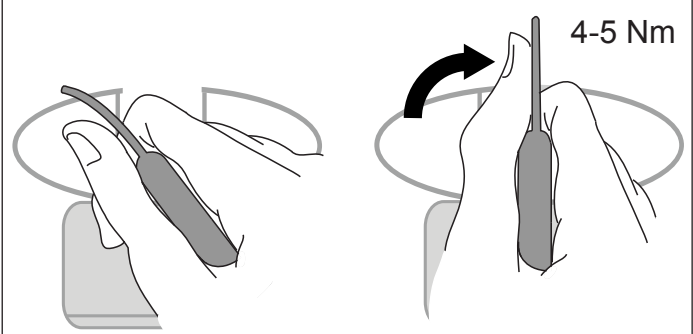

With Torque Key inserted, turn clockwise until handle straightens out as shown above. This indicates 4-5 Nm. More pressure may be required in extreme climates.

8a

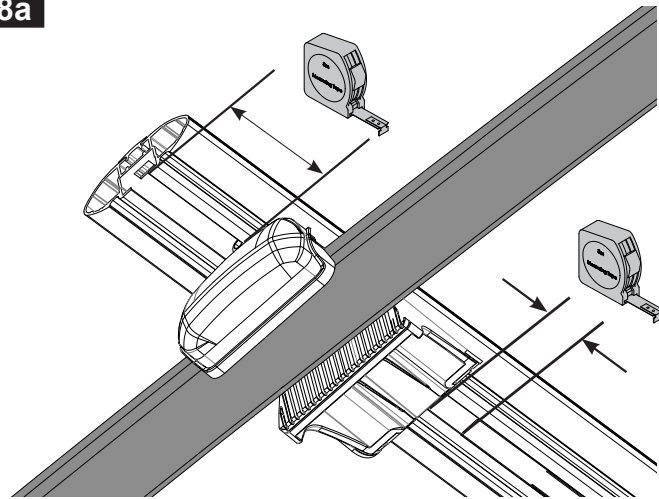

8b

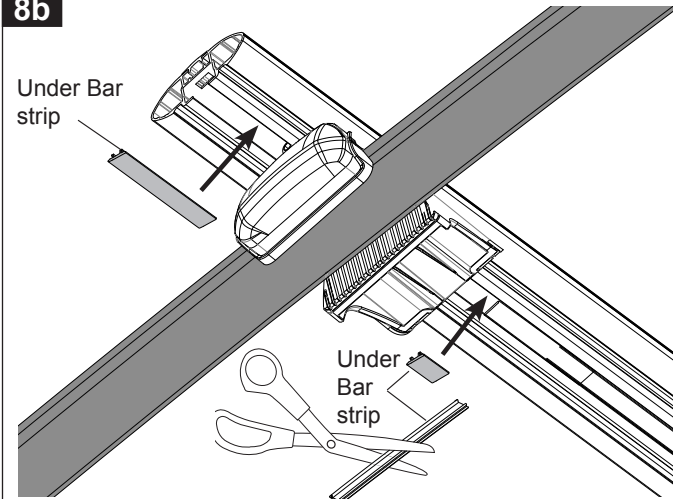

9a Insert End Cap as shown.

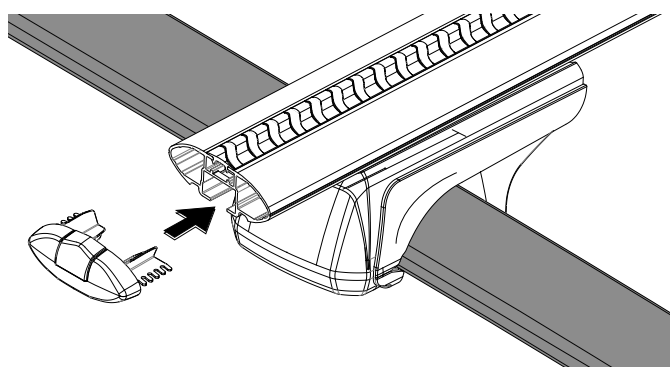

9b NOTE: Locking End Cap is an optional extra.

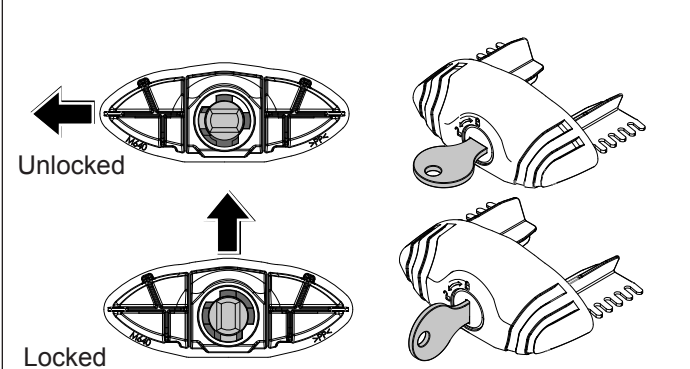

10

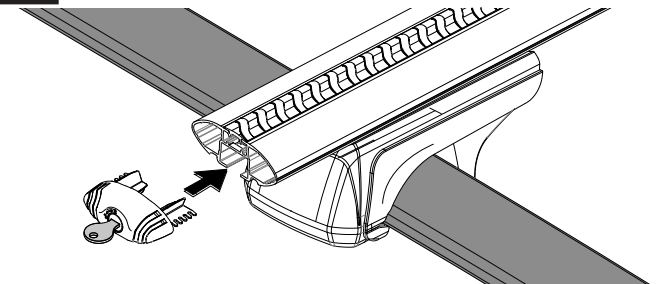

Insert Locking End Cap and remove key

11

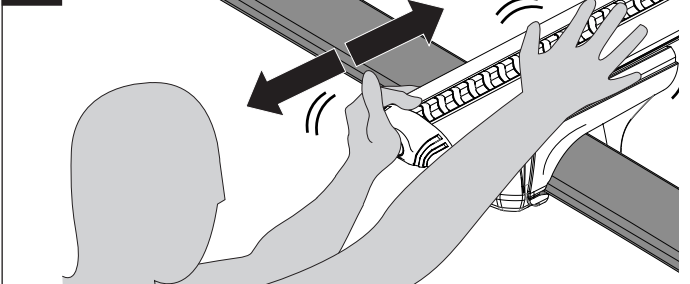

Test racks are secure