



RHINO-RACK

CONTROLLED

Iveco Daily Daily H1 3520 WB RLT600 Crossbar Fitment

Important: Please read these instructions carefully prior to and during installation.
Check the contents of kit before commencing fitment and report any discrepancies.

Item	Components	VA Qty	HD Qty	Part No.
1	Vortex Crossbar	2-3	-	VA165S/B
2	Heavy Duty Crossbars	-	2-3	RB1650S/B
3a	RLT600 Canopy Mount Kit	1	1	QMCM01
3b	RLT600 Canopy Mount half Kit (3 bar systems only)	1	1	QMCM02
*4	Quick Mount HD Spacer 5mm	-	2-3	QMHD05
5a	Leg and Base Kit	1	1	RLT600
5b	Leg and Base half Kit (3 bar only)	1	1	RLT600H
6	Rubber base kit	1	1	QMFK06 or QMFK05 for 3 bar
7	Fitting Instructions	1	1	R1591

* For use with Pioneer Tray/ Platform. Optional when using HD or Vortex Bars.

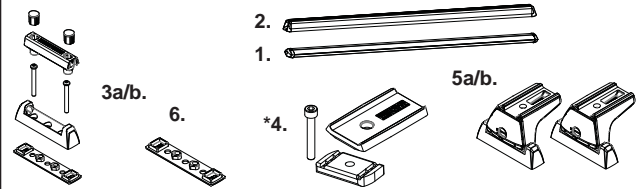

- Tools Required:**
- Cotton buds
 - Masking tape
 - Cold Galvanising Paint
 - Vacuum
 - Marking Pen
 - Tape measure
 - Power Drill
 - 6.5mm drill bit + Stop
 - Hole Punch
 - Butyl mastic

Note: All parts are sold as separate. Ensure you have the required kits to complete your fitment.

Instructions

1 Apply masking tape along the ditch on the roof of the vehicle in the approximate working area.

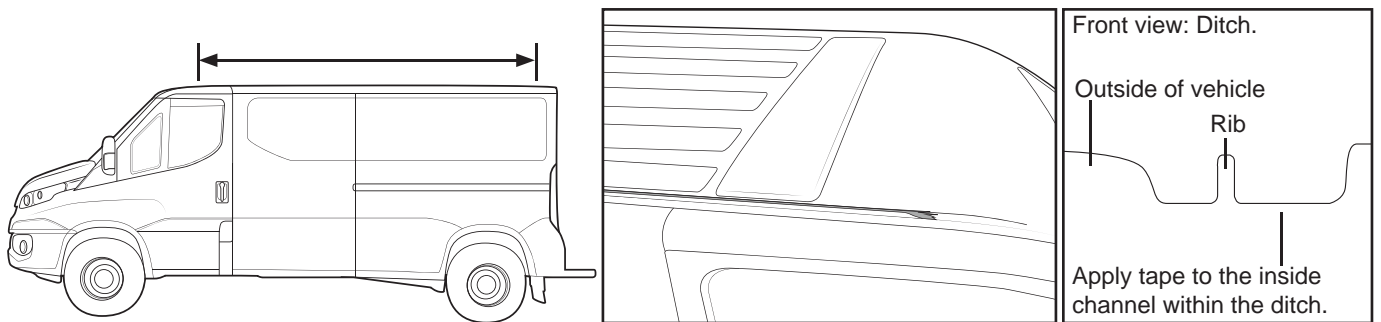

2 Top View: Place an RLT600 base 230mm from the rear of the rib within the ditch.

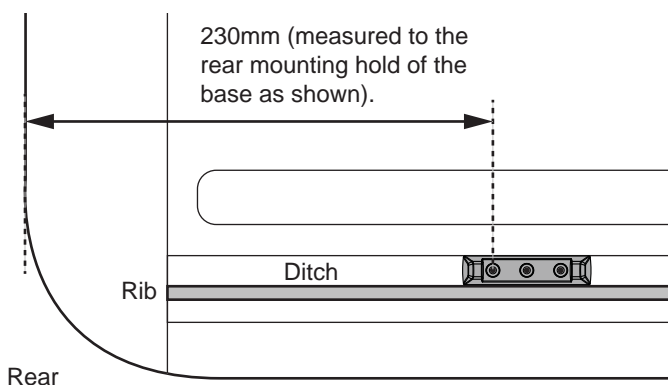

3 Place the remaining brackets into the ditch as shown.

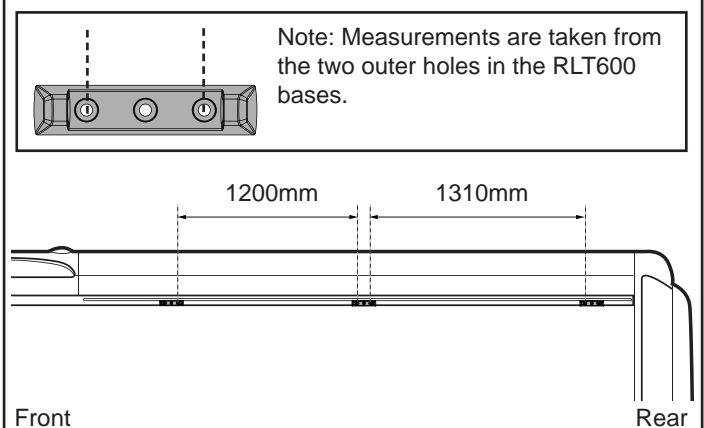

4 Mark the two outer holes of the brackets onto the tape below.

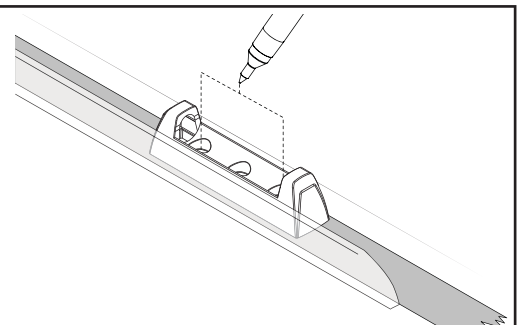
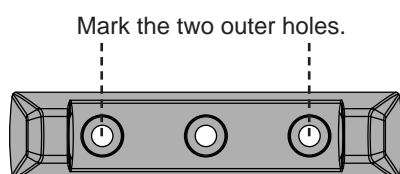



Iveco Daily Daily H1 3520 WB RLT600 Crossbar Fitment

5 Remove the bases and using a hole punch, strike the marks made previous. This will create a guide while drilling.

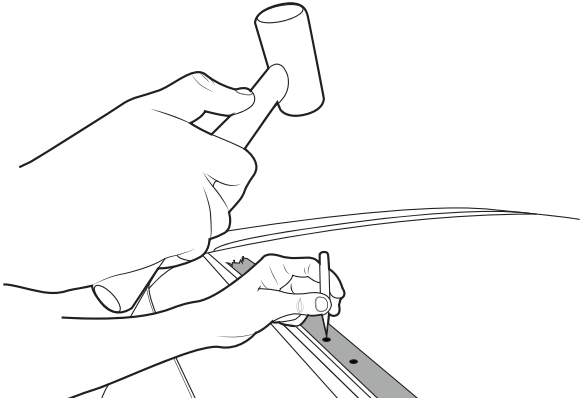

6 Drill the roof through the references made in step 4 using 6.5mm drill bit.

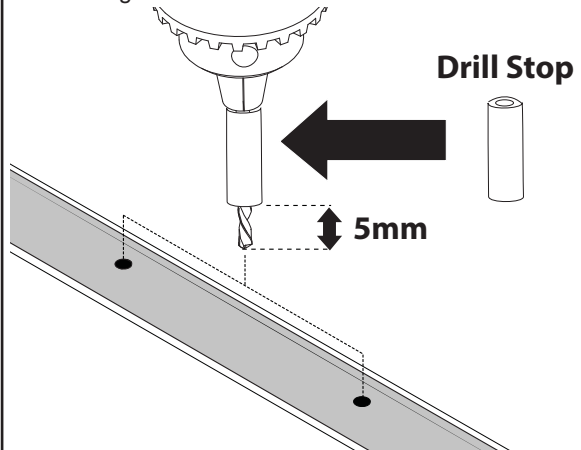

7 Vacuum any swarf caused by drilling. Remove the tape. Vacuum from the inside as well also.

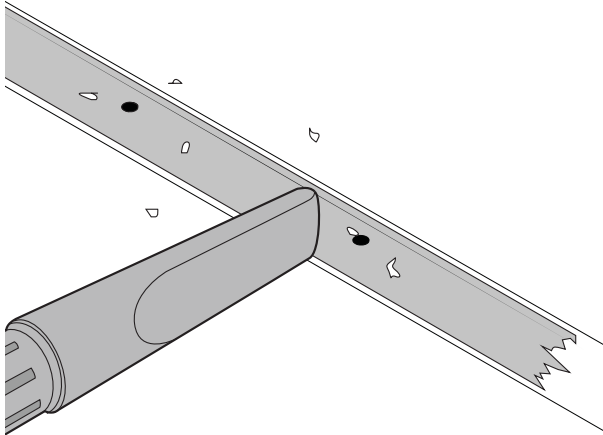

8 Remove the Tape and using cold galvanising paint, coat all drilled holes and any exposed body work.

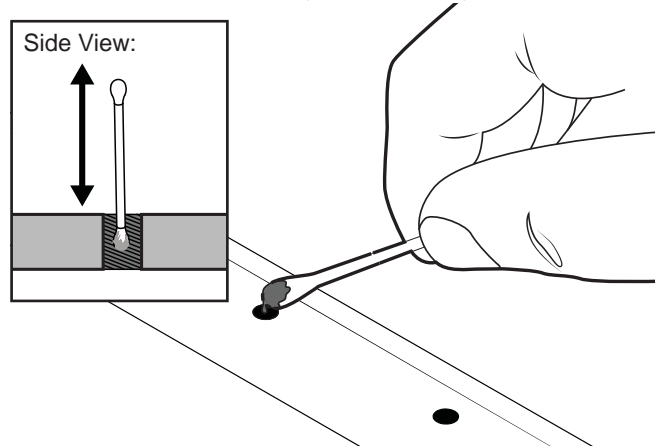

9 Apply butyl mastic to all holes in the roof of the vehicle.

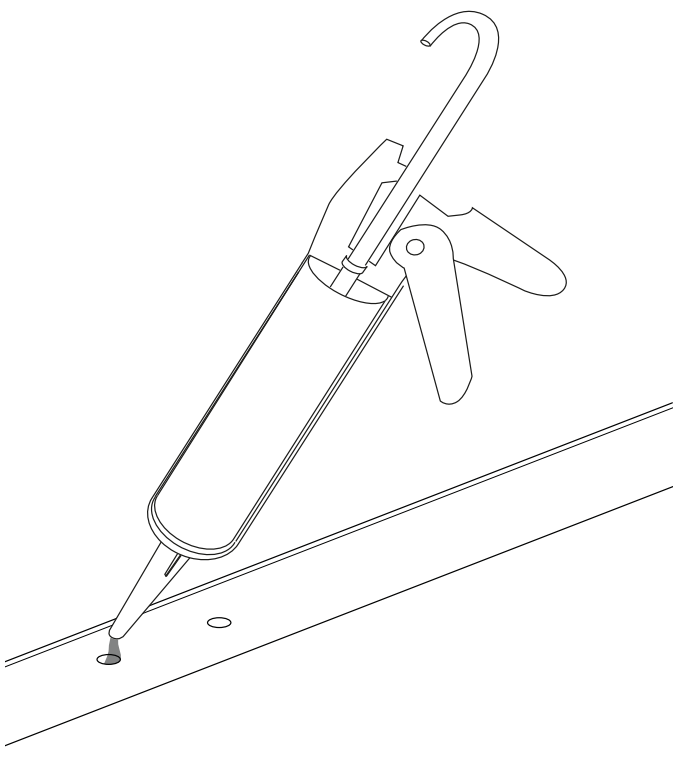

10 Fit the QMCM01 bases on the inside of the vehicle in place.

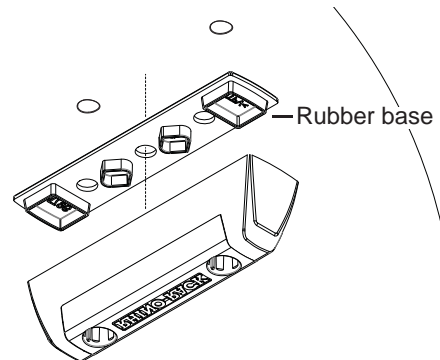

Use masking tape to hold the base in place.

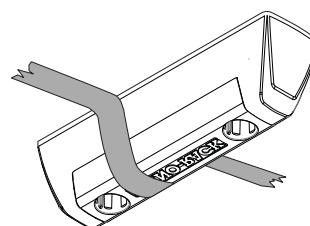



Iveco Daily Daily H1 3520 WB RLT600 Crossbar Fitment

11 Install the RLT600 bases to the top of the vehicle. The hardware will fix into the QMCM01 bases below.

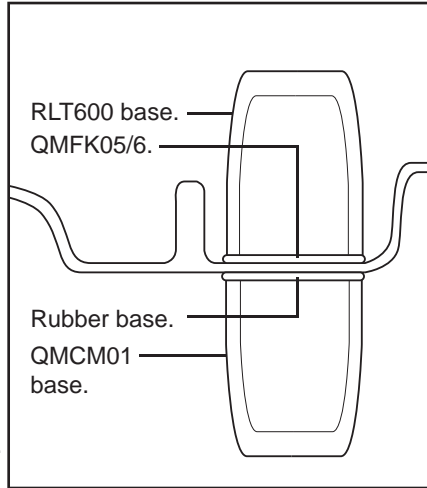
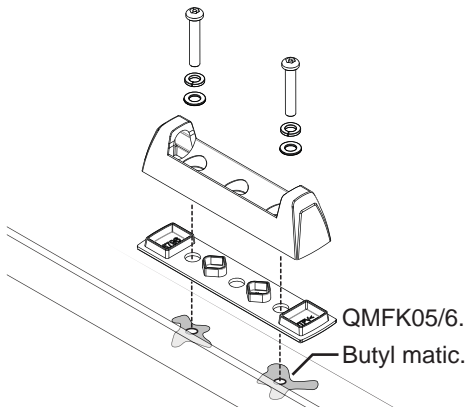

With the hardware installed, remove the tape from the QMCM01 bases and install the provided screw covers.

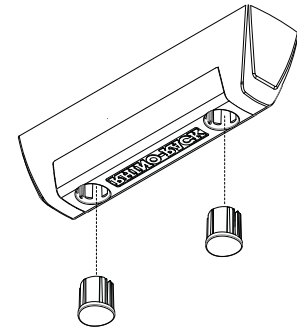

Note Install leg kits as per corresponding instructions.

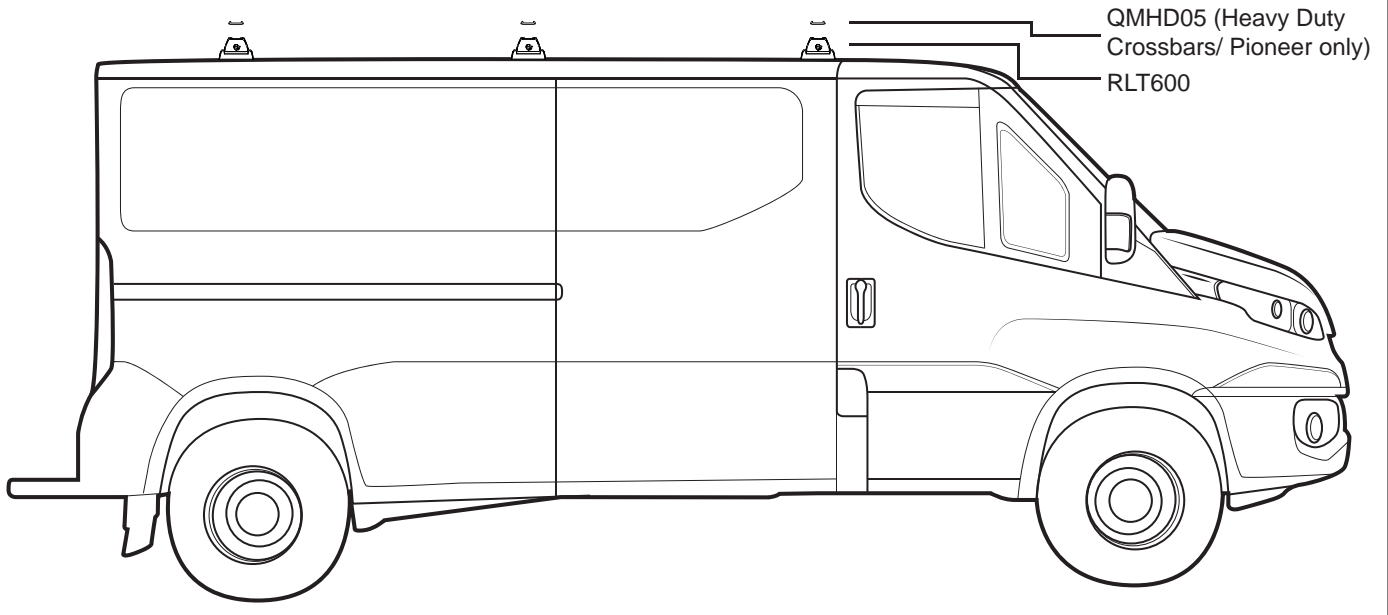

Rhino-Rack
3 Pike Street, Rydalmere,
NSW 2116, Australia.
(Ph) (02) 9638 4744
(Fax) (02) 9638 4822

Document No: R1591
Prepared By: Kayle Everett
Authorised By: Chris Murty

Fit Time: 1 Hour
Issue No: 02
Issue Date: 09/11/17

These instructions remain the property of Rhino-Rack Australia Pty. Ltd. and may not be used or changed for any other purpose than intended.