



# RHINO-RACK®

## HONDA CR-V Base Kit

RCP01-BK

**Important:**

1. Check the Rhino-Rack website to ensure you have the latest issue of these instructions.
2. Please refer to your fitting instruction to ensure that the roof racks are installed in the correct locations.
3. Check the contents of kit before commencing fitment and report any discrepancies.
4. Place these instructions in the vehicle's glove box after installation is complete.
5. These instructions must be followed for warranty to be upheld.

**Fit Time:** 30 min

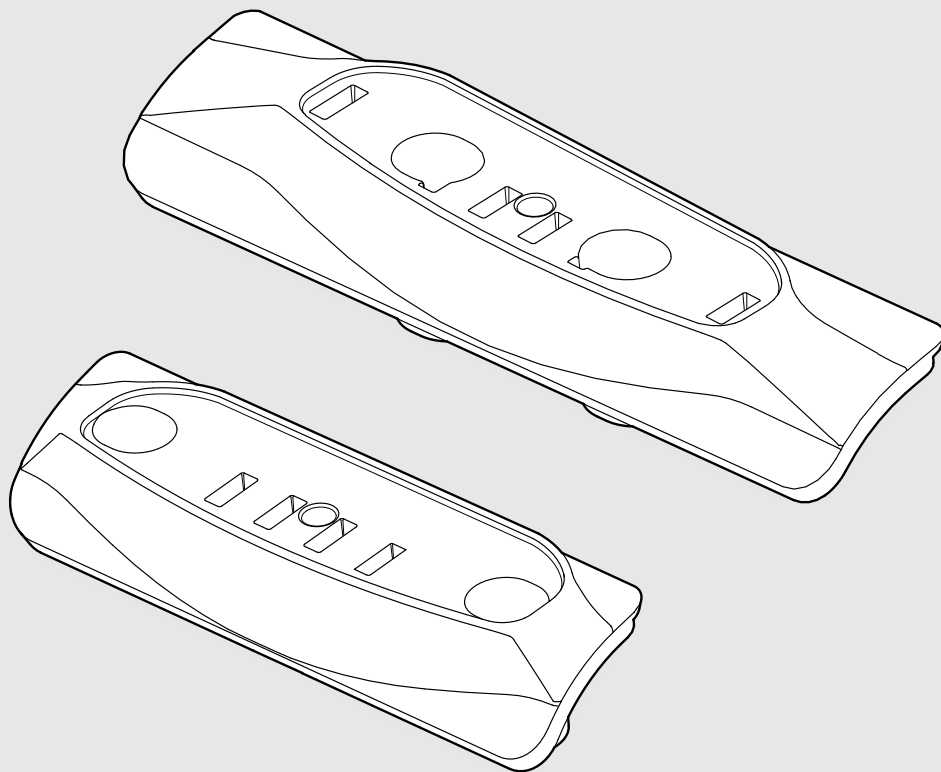

**Rhino-Rack AUSTRALIA**  
22A Hanson Pl,  
Eastern Creek, NSW, 2766  
(02) 8846 1900  
rhinorack.com.au

**Rhino-Rack USA**  
Unit D, 2450 Airport Blvd,  
Aurora, CO, 80011  
877-744-6622  
rhinorack.com

**Rhino-Rack CANADA**  
19100 Airport Way  
Pitt Meadows, BC V3Y OE2  
rhinorack.ca

Document No: R1286  
Issue No: 02  
Issue Date: 8/10/2021

# RCP01-BK Instructions

## Carrying Capacity

Check the website and the vehicle owners hand book for your vehicle manufacturer's maximum carrying capacity. Load must be evenly distributed over the system.

VISIT THE ONLINE CALCULATOR FOR CURRENT SYSTEM LOAD LIMIT DATA

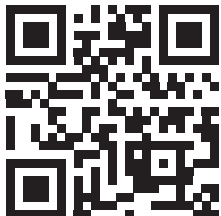

**DYNAMIC CROSS BAR LOAD LIMIT:**  
**\*USE THE VEHICLE MANUFACTURER'S MAXIMUM ROOF ALLOWANCE IF IT IS LOWER THAN THE FIGURE LISTED**

 CARGO	 SYSTEM WEIGHT	 LOAD LIMIT	<b>OR</b>	 Max kg
UP TO <b>95 KG</b> <b>209 lbs</b>	<b>+</b> <b>5 KG</b> <b>11 lbs</b> <b>=</b>	UP TO <b>100 KG</b> <b>220 lbs</b>		<b>*VEHICLE MANUFACTURER'S ROOF LOAD LIMIT</b>



### Cargo Load Limit

Total permissible weight allowed on top, and attached to roof racks whilst the vehicle is in motion.

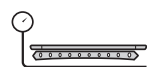

### System Weight

Total weight of the roof rack system. (e.g. Crossbars, Backbone, Platform)



### Max System Load Capacity

Please ensure you use the vehicle manufacturer's maximum roof allowance if it is lower than the figure listed in the fitting chart/supplement.



### Vehicle Manufacturer's Load Limit

Total permissible weight attached to the roof of the car. This is inclusive of the weight of the roof rack system.

## Warning

- Check part number or kit is correct for use with your vehicle.
- Do not attempt to fit the rack system to your vehicle unless you fully understand these fitting instructions. Please direct any questions regarding fitting to the dealer from where the roof racks were purchased.
- Off-road conditions can be much more rigorous. Extreme care must be taken on any driven path that does not contain a surface protection layer (tar/bitumen).
- Roof racks must be removed when vehicle is put through an automatic car wash.
- With utility vehicles, the cabin and the canopy move independently. Roof racks and vehicle can be damaged if the item transported is rigidly fixed at points on both the cabin and canopy. Instead, rigidly fix to either the cabin roof racks or the canopy roof racks.
- Always ensure you fasten your load securely.
- Use only non-stretch fastening ropes or straps to attach cargo to your load.

## In service maintenance checks

- All bolt connections should be checked after driving a short distance when you first install your roof racks.
- All bolted connections should be checked again at regular intervals (weekly is recommended, depending on road conditions, usage, loads and distances travelled).
- All bolted connections should be checked each time they are re-fitted.
- Off-road conditions are more rigorous. Check all bolted connections and your load more regularly.
- Ensure that your vehicle manufacturer's GVM, and gross axle weights are not exceeded (refer to vehicle owner's manual).

### Torque Settings

Unless stated otherwise in these instructions, all fasteners should be set to the following torque settings:

M6: 4-5Nm (3-4lbs/ft),

M8: 8-10Nm (6-7.5lbs/ft)

M10: 16-18Nm (12-13lbs/ft).

## Note for Dealers and Fitters

It is your responsibility to ensure these fitting instructions are given to the end user or client. These instructions remain the property of Rhino-Rack Australia Pty. Ltd. and may not be used or changed for any other purpose than intended.

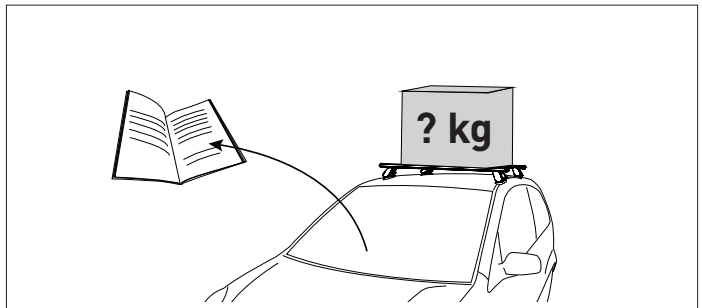
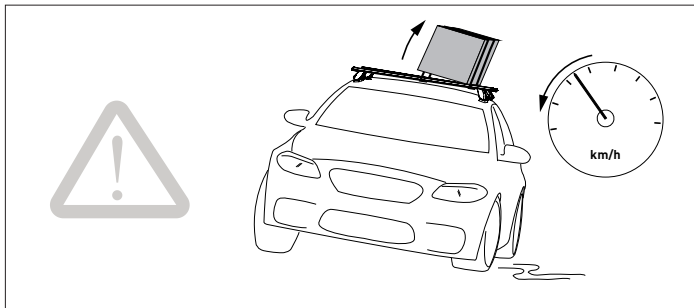
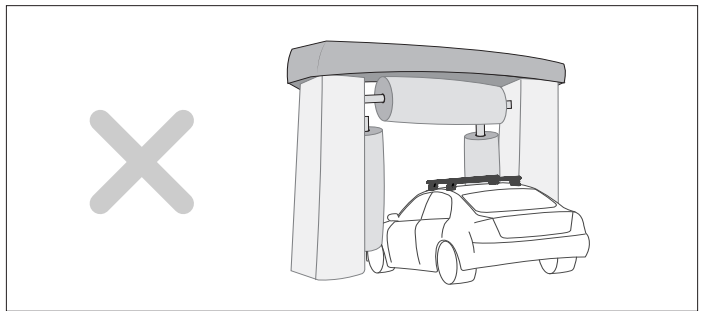
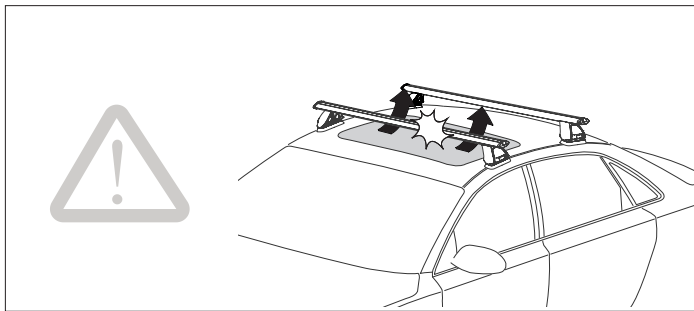
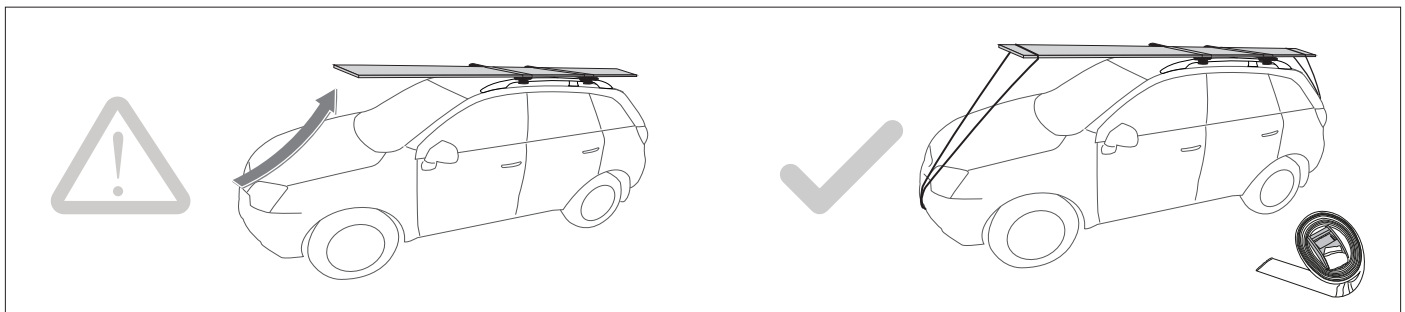

The handling characteristics of the vehicle changes when a load is transported on the roof. Exercise extreme care when transporting wind-resistant loads. Special consideration must be taken when cornering and braking.

Off-road conditions can be much more rigorous. Extreme care must be taken in off-road conditions.





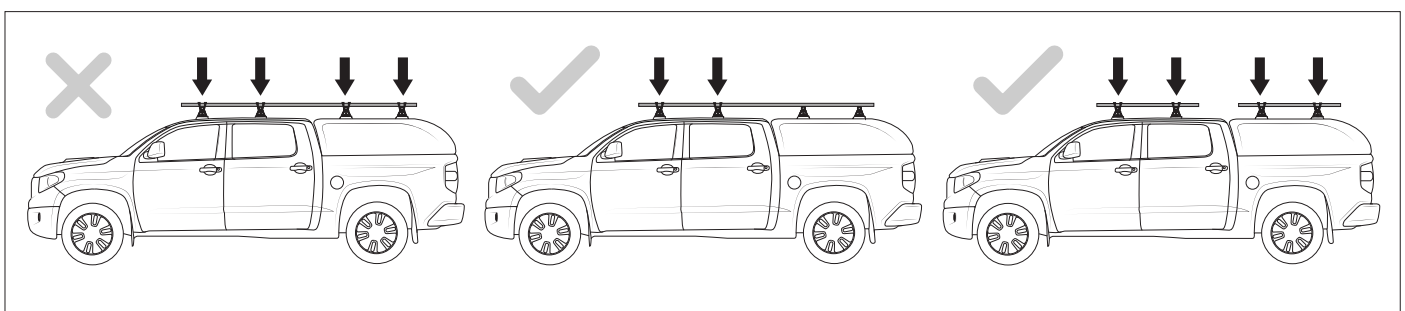

Ensure Ladder is well supported on the ground to support tent. Take extreme caution when climbing heights above 1.2m/4ft.

Paddle/ Surfboards should be fixed to the front of the vehicle.

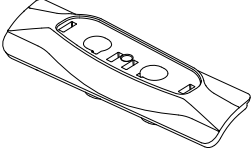
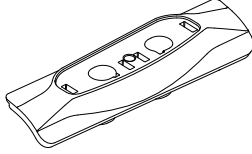
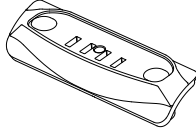
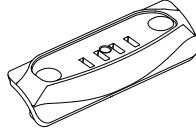
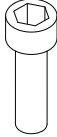

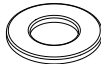
# RCP01-BK Instructions

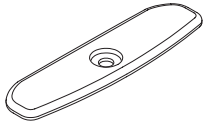
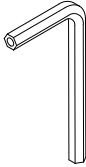
## Parts List

<p>Front Left Mounting Pad</p>  <p><b>A</b> x1</p>	<p>Front Right Mounting Pad</p>  <p><b>B</b> x1</p>	<p>Rear Left Mounting Pad</p>  <p><b>C</b> x1</p>	<p>Rear Right Mounting Pad</p>  <p><b>D</b> x1</p>
<p>M6 x 16mm Socket Head Cap Screw</p>  <p><b>E</b> x8</p>	<p>M6 Spring Washer</p>  <p><b>F</b> x12</p>	<p>M6 x 12.5mm Flat Washer</p>  <p><b>G</b> x12</p>	<p>M6 x 30mm Hex Setscrew</p>  <p><b>H</b> x4</p>
<p>M6 x 16mm Flat Washer</p>  <p><b>I</b> x4</p>	<p>Pad Cover Plates</p>  <p><b>J</b> x4</p>	<p>5mm Security Allen Key</p>  <p><b>K</b> x1</p>	<p>Instructions</p>  <p><b>L</b> x1</p>

### Tools required:

- T1 - Small Flat head Screwdriver
- T2 - 10mm Socket Wrench / Spanner
- T3 - Cleaning Cloth

1

Remove the four covers from the roof rack mounting locations.

Lever upwards carefully.

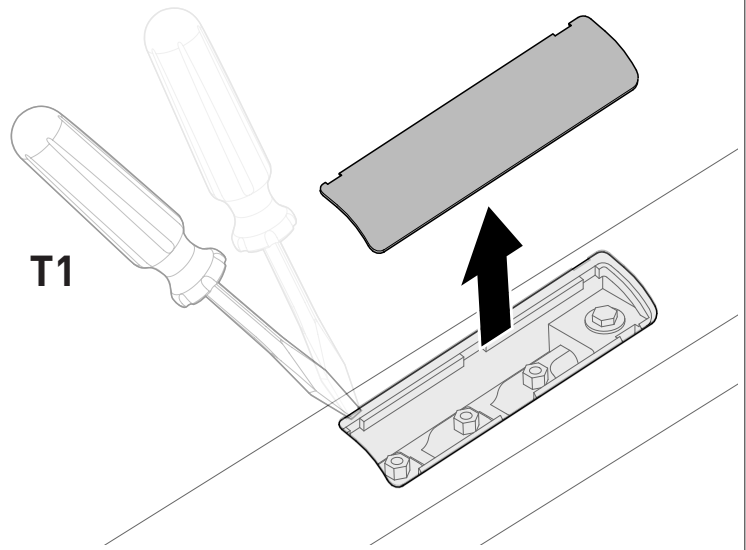

2

Test factory mounting point threads by fitting then removing bolts. Care should be taken not to damage the paint under the nutsert.

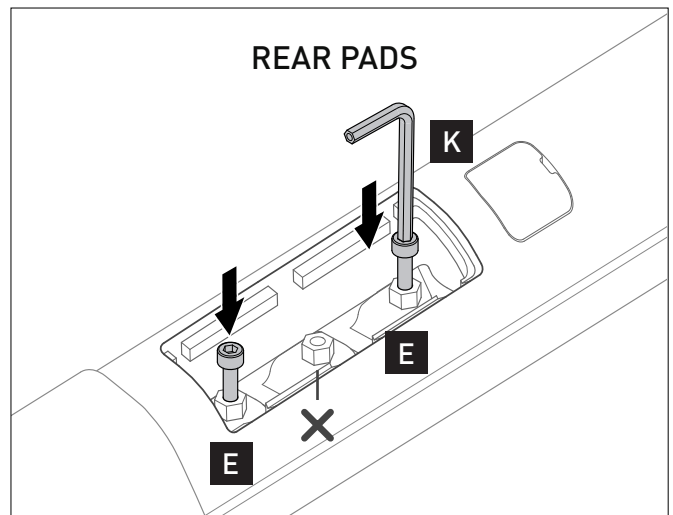
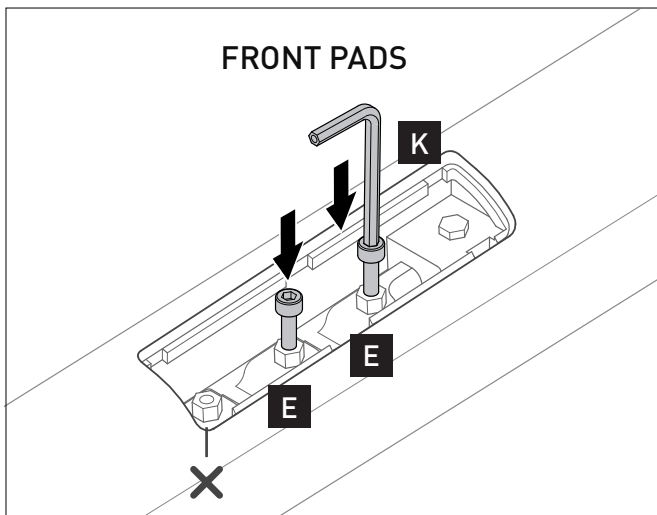

3

Place all four mounting pads into their positions: Front Left, Front Right, Rear Left and Rear Right.

UNDERSIDE VIEW:

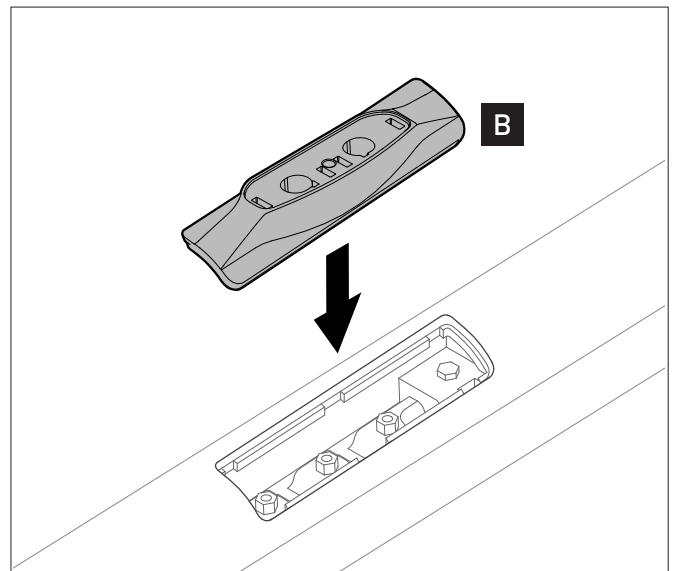
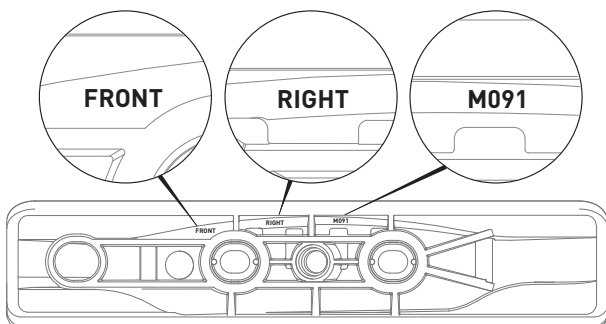

4

Repeat for all 4 mounting pads.



**Do not overtighten.**

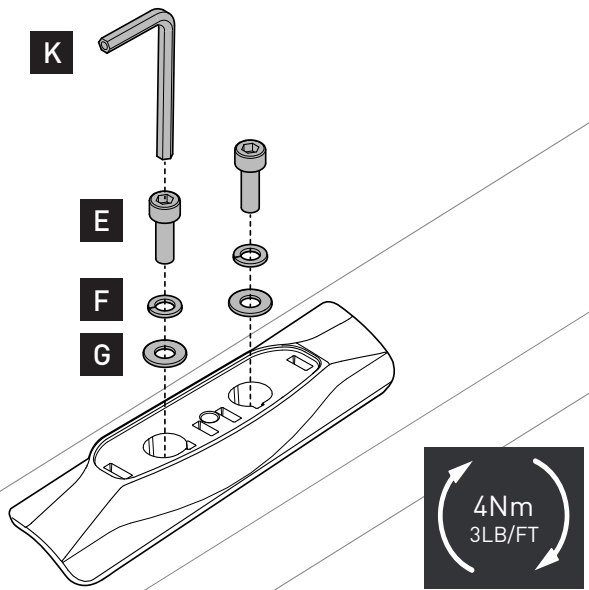

5

**Note:** Crossbar as example only.  
Fit as per corresponding instructions.

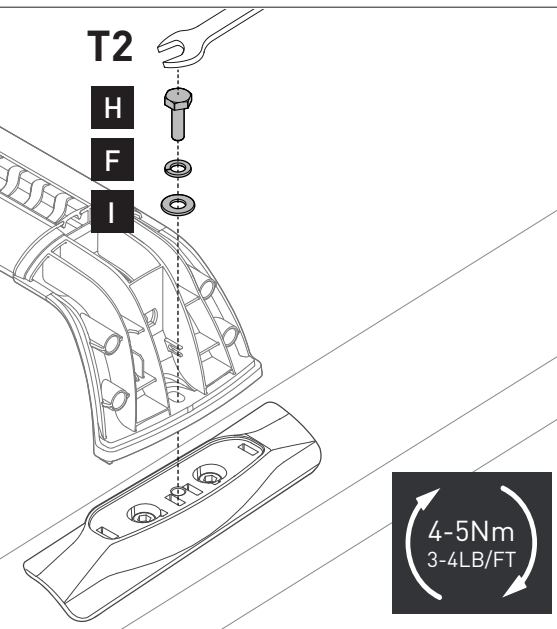

6

When crossbars are not in use,  
install the cover plates.

