



# RHINO-RACK®

## MITSUBISHI TRITON MQ / MR Backbone RMTB1

**Important:**

1. Check the Rhino-Rack website to ensure you have the latest issue of these instructions.
2. Please refer to your fitting instruction to ensure that the roof racks are installed in the correct locations.
3. Check the contents of kit before commencing fitment and report any discrepancies.
4. Place these instructions in the vehicle's glove box after installation is complete.
5. These instructions must be followed for warranty to be upheld.

**Fit Time:** 1 hour

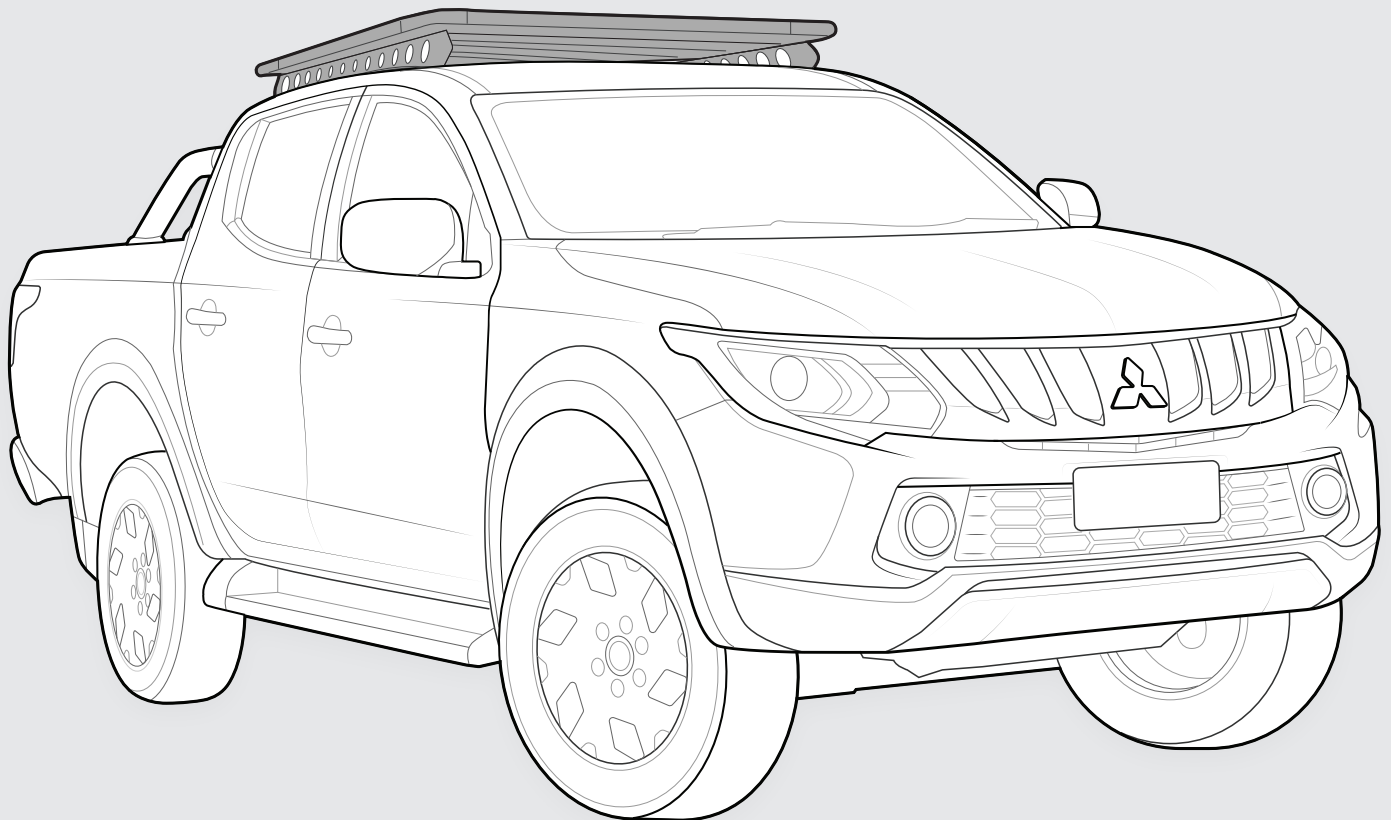

**Rhino-Rack AUSTRALIA**  
22A Hanson Pl,  
Eastern Creek, NSW, 2766  
(02) 8846 1900  
rhinorack.com.au

**Rhino-Rack USA**  
Unit D, 2450 Airport Blvd,  
Aurora, CO, 80011  
877-744-6622  
rhinorack.com

**Rhino-Rack CANADA**  
19100 Airport Way  
Pitt Meadows, BC V3Y OE2  
rhinorack.ca

Document No: R1202  
Issue No: 08  
Issue Date: 13/09/2021

# RMTB1 Backbone Instructions

---

## Carrying Capacity

---

Check the website and the vehicle owners hand book for your vehicle manufacturer's maximum carrying capacity. Load must be evenly distributed over the system.

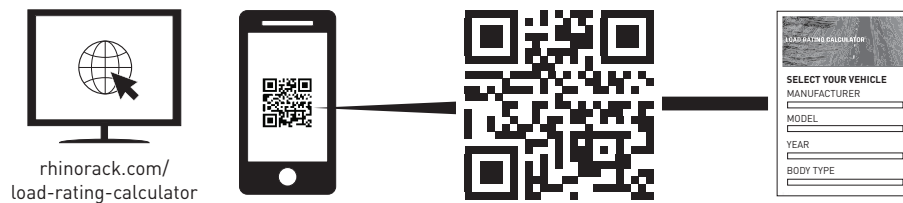

### Cargo Load Limit

---

Total permissible weight allowed on top, and attached to the rack whilst the vehicle is in motion.

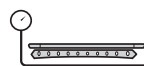

### System Weight

---

Total weight of the rack system. (e.g. Crossbars, Backbone, Platform)



### Max System Load Capacity

---

Please ensure you use the vehicle manufacturer's maximum roof allowance if it is lower than the figure listed in the fitting chart/supplement.



### Vehicle Manufacturer's Load Limit

---

Total permissible weight attached to the rack. This is inclusive of the weight of the rack system.

## Warning

---

- Check part number or kit is correct for use with your vehicle.
- Do not attempt to fit the rack system to your vehicle unless you fully understand these fitting instructions. Please direct any questions regarding fitting to the dealer from where the roof racks were purchased.
- Off-road conditions can be much more rigorous. Extreme care must be taken on any driven path that does not contain a surface protection layer (tar/bitumen).
- Racks must be removed when vehicle is put through an automatic car wash.
- With utility/pick up vehicles, the cabin and the utility tray/truck bed move independently. Racks and vehicle can be damaged if the item transported is rigidly fixed at points on both the cabin and utility tray/truck bed. Instead, rigidly fix to either the utility tray/bed racks or the canopy roof racks.
- Always ensure you fasten your load securely.
- Use only non-stretch fastening ropes or straps to attach cargo to your load.

## In service maintenance checks

---

- All bolt connections should be checked after driving a short distance when you first install your roof racks.
- All bolted connections should be checked again at regular intervals (weekly is recommended, depending on road conditions, usage, loads and distances travelled).
- All bolted connections should be checked each time they are re-fitted.
- Off-road conditions are more rigorous. Check all bolted connections and your load more regularly.
- Ensure that your vehicle manufacturer's GVM, and gross axle weights are not exceeded (refer to vehicle owner's manual).

### Torque Settings

Unless stated otherwise in these instructions, all fasteners should be set to the following torque settings:

- M6: 4-5Nm (3-4lbs/ft),
- M8: 8-10Nm (6-7.5lbs/ft)
- M10: 16-18Nm (12-13lbs/ft).

## Note for Dealers and Fitters

---

It is your responsibility to ensure these fitting instructions are given to the end user or client. These instructions remain the property of Rhino-Rack Australia Pty. Ltd. and may not be used or changed for any other purpose than intended.

# RMTB1 Backbone Instructions

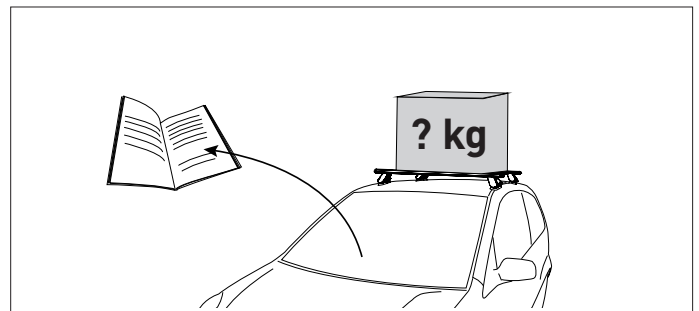
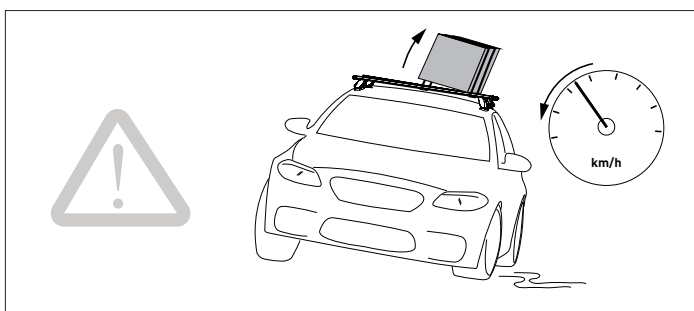
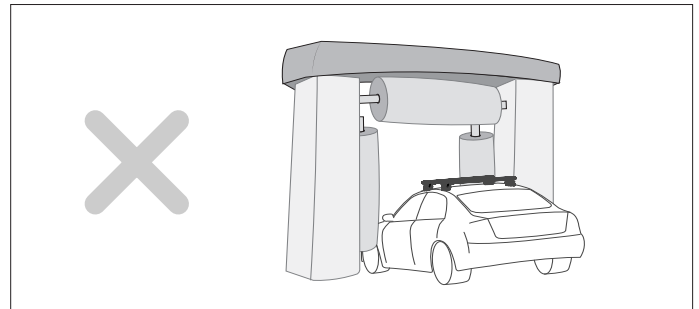
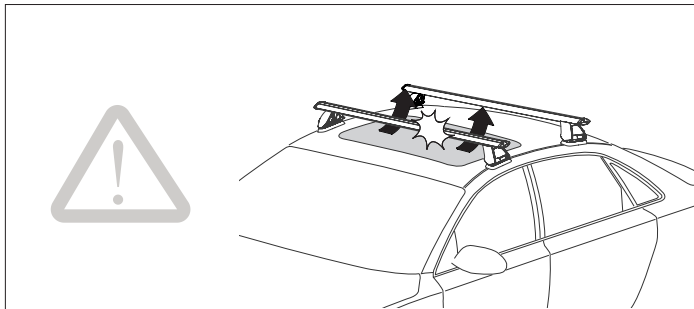
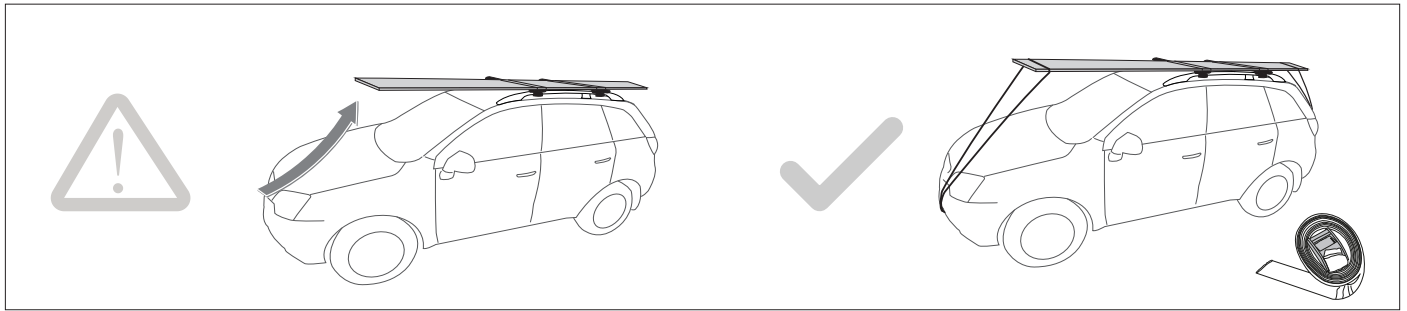

The handling characteristics of the vehicle changes when a load is transported on the roof. Exercise extreme care when transporting wind-resistant loads. Special consideration must be taken when cornering and braking.

Off-road conditions can be much more rigorous. Extreme care must be taken in off-road conditions.

Ensure Ladder is well supported on the ground to support tent. Take extreme caution when climbing heights above 1.2m/4ft.

Paddle/ Surfboards should be fixed to the front of the vehicle.

# RMTB1 Backbone Instructions

## Parts List

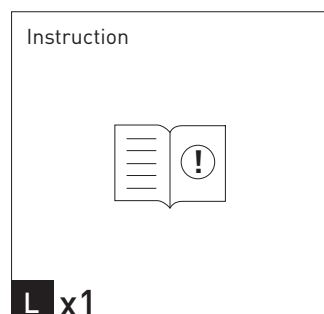
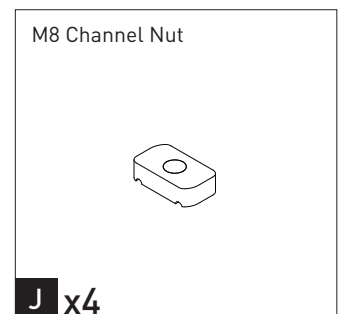
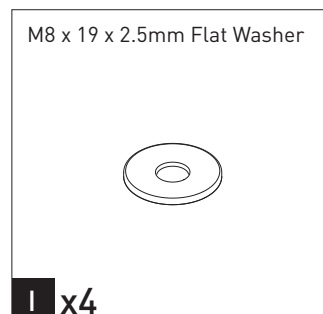
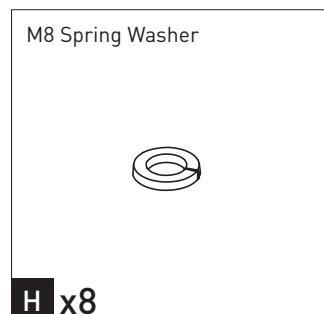
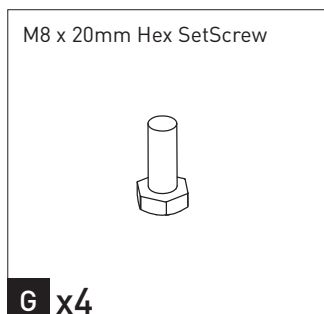
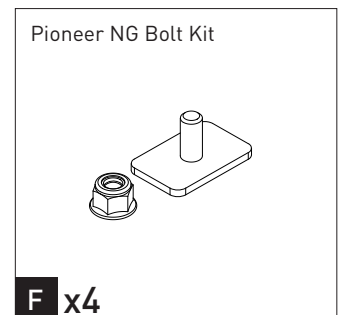
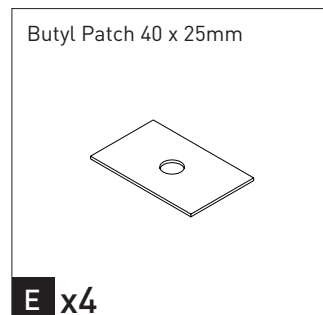
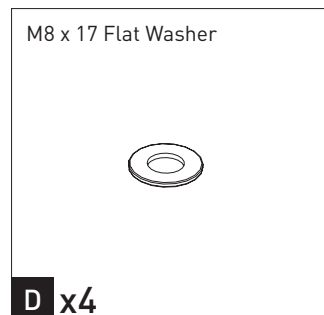
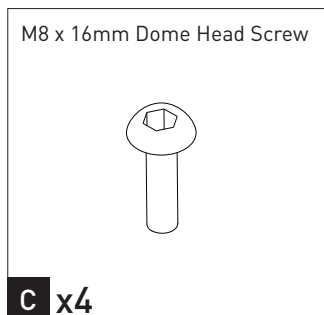
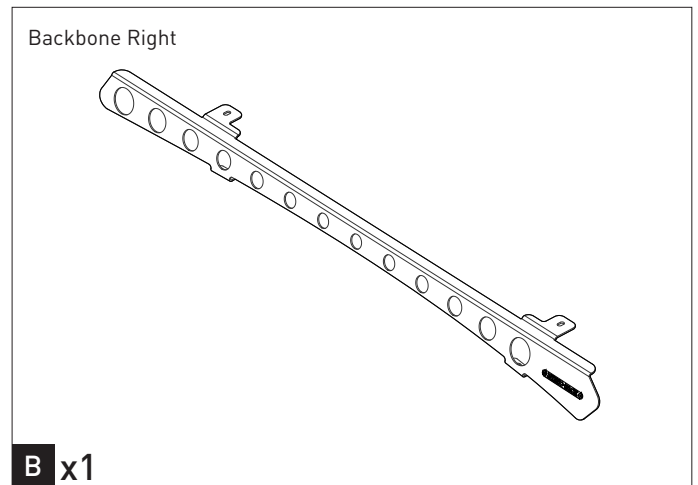
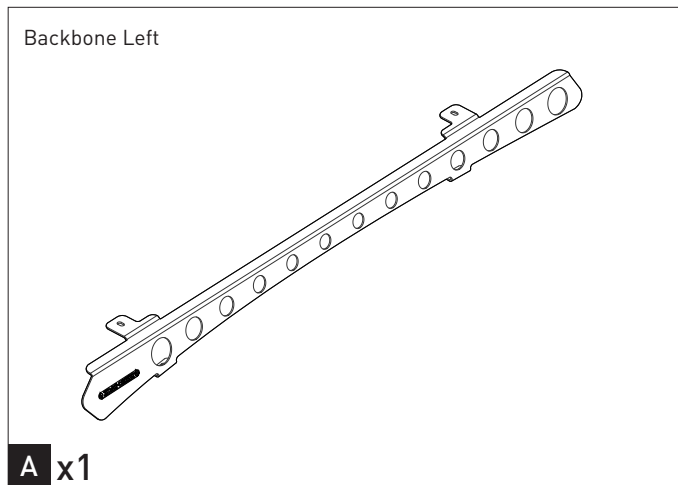

### Tools Required:

- T1 - 13mm Socket Wrench/ Spanner
- T2 - Measuring Tape
- T3 - Marker
- T4 - Cutters

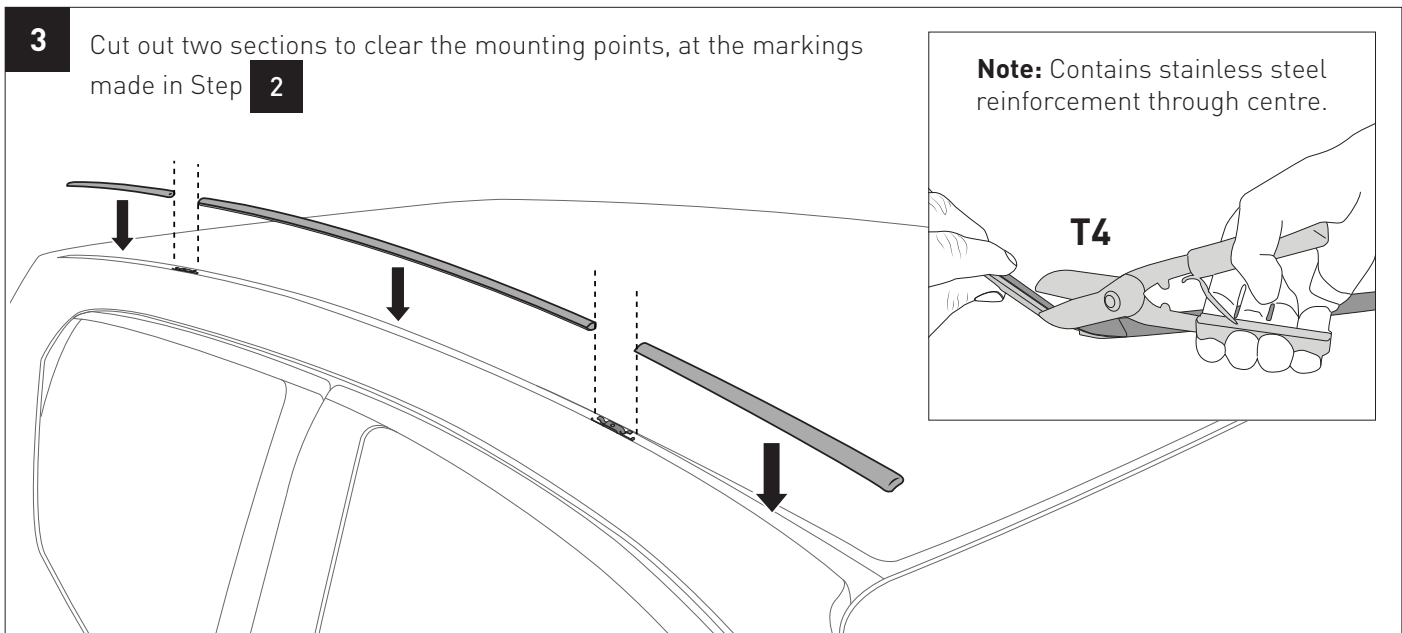
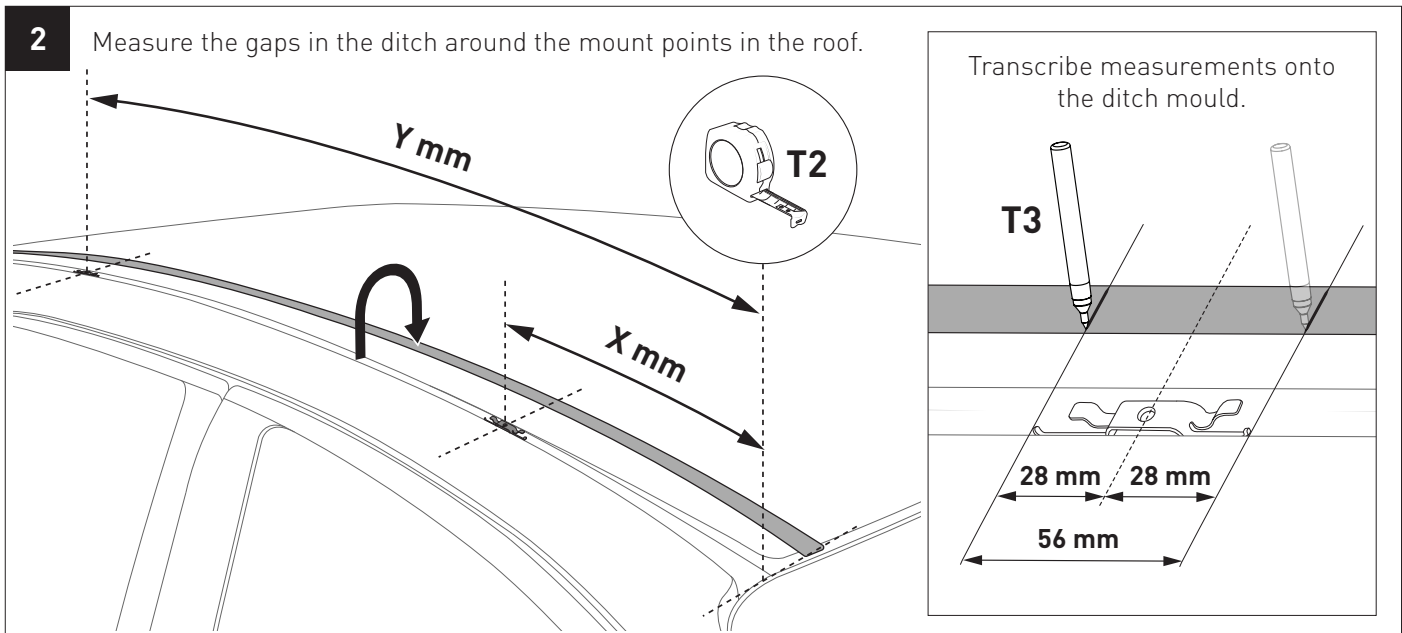
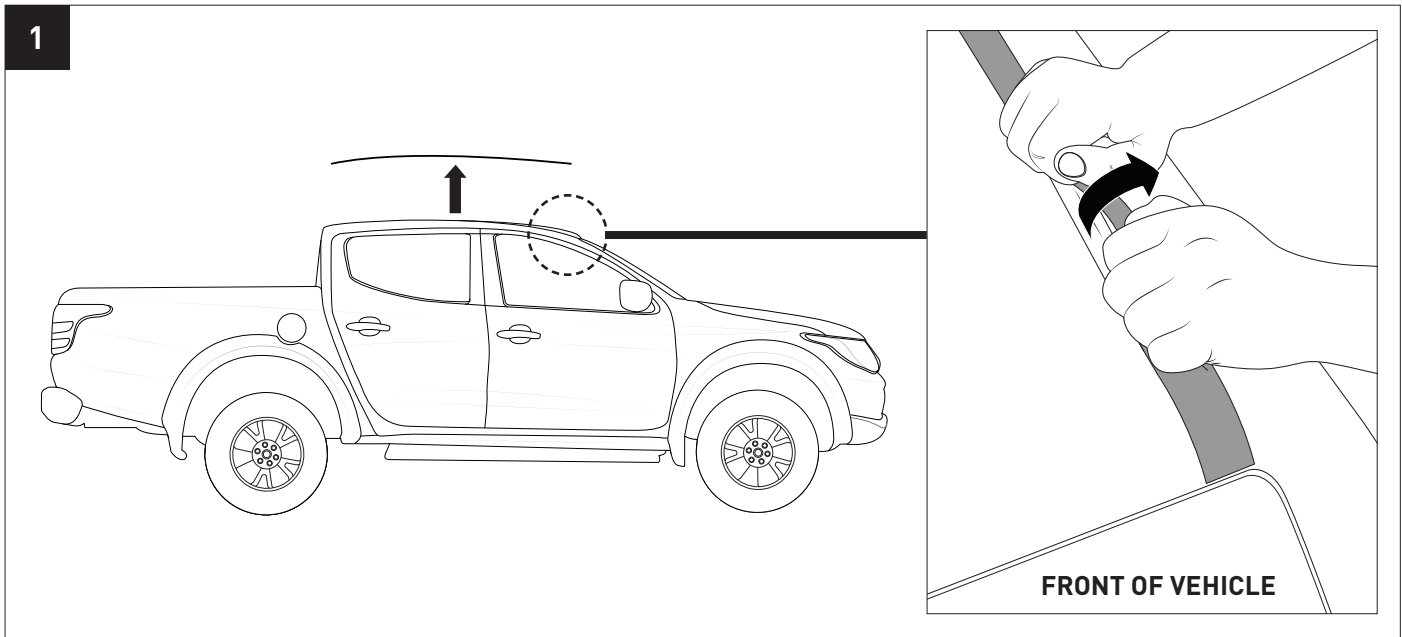

4

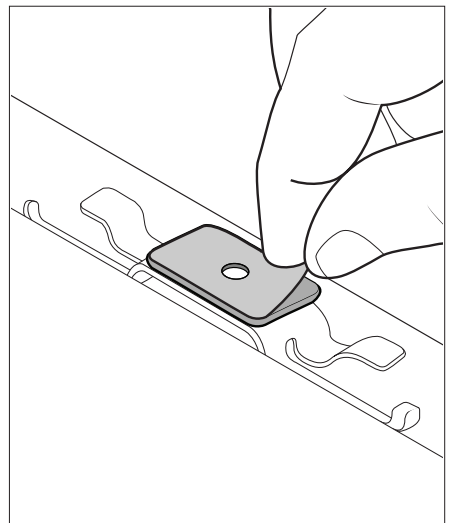
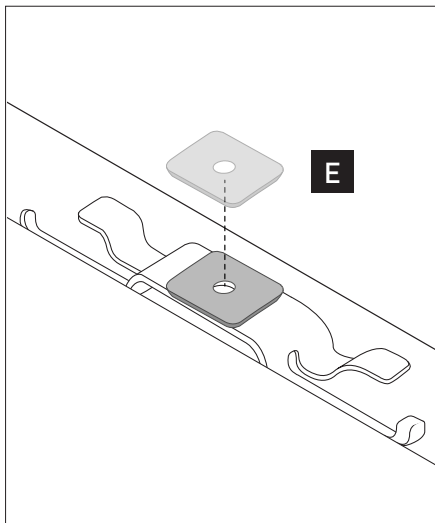
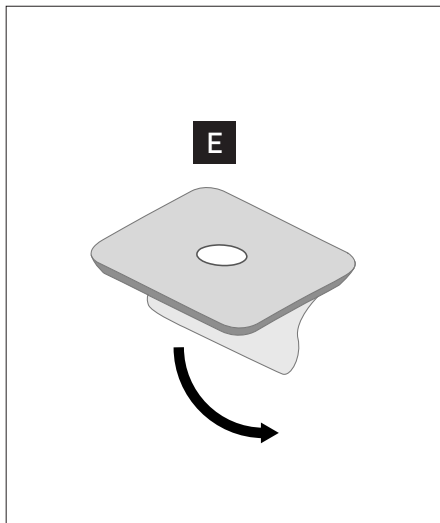

5

**Note:** Rhino Rack Badge indicates the front end of the backbone.

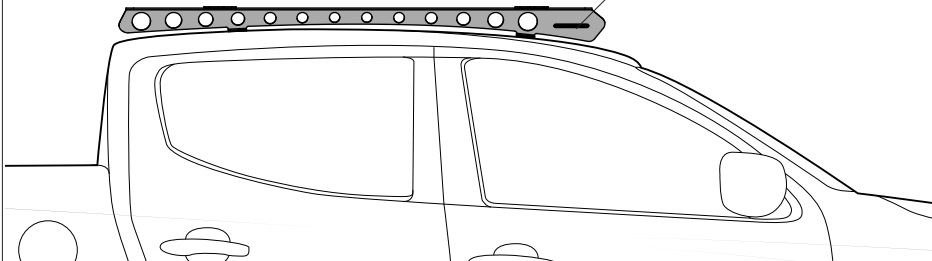
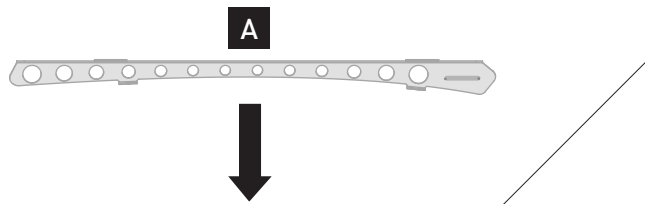

FRONT VIEW



Metal Tabs face inwards toward the vehicle.

6

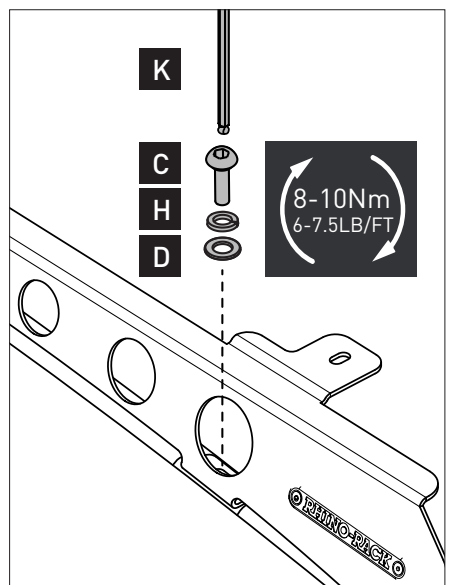
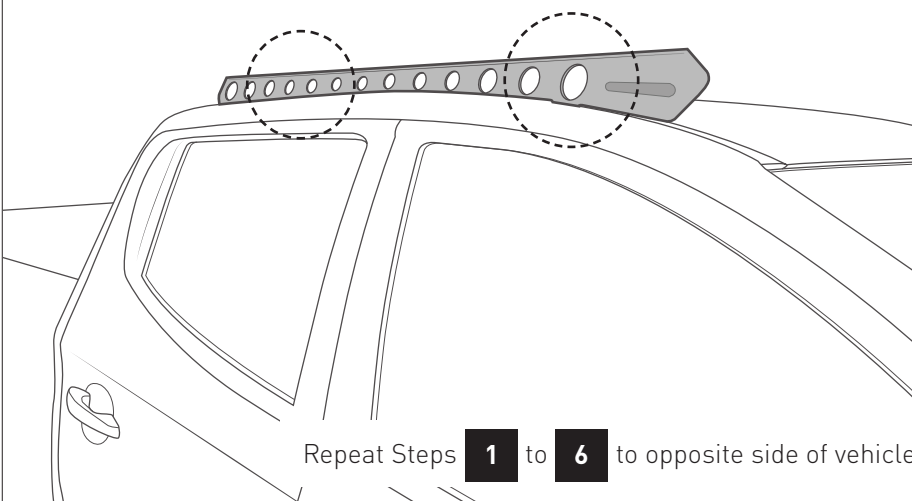

**7** PLATFORM INSTALLATION



rhinorack.com/roof

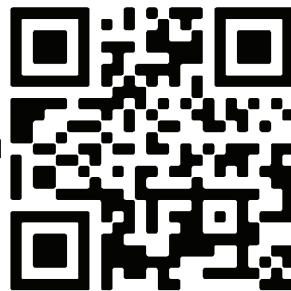

EXAMPLE ONLY

**RHINO-RACK | PIONEER VEHICLE FITTING INFORMATION**

| VEHICLE   | MODEL | YEAR | POSITION | LOAD CAPACITY |
|---|-------|------|----------|---------------|
| *UNDESIGNED AND/OR MODIFIED VEHICLES MAY NOT BE ELIGIBLE FOR INSTALLATION |       |      |          |               |
| VEHICLE   | MODEL | YEAR | POSITION | LOAD CAPACITY |
| VEHICLE   | MODEL | YEAR | POSITION | LOAD CAPACITY |
| VEHICLE   | MODEL | YEAR | POSITION | LOAD CAPACITY |
| VEHICLE   | MODEL | YEAR | POSITION | LOAD CAPACITY |
| VEHICLE   | MODEL | YEAR | POSITION | LOAD CAPACITY |

NOTE: THE DESIGN OF THIS RACK IS BASED ON THE FOLLOWING ASSUMPTIONS:

- THE VEHICLE MANUFACTURER'S RECOMMENDED ROOF ALLOWANCE IS FOLLOWED UNLESS OTHERWISE SPECIFIED.
- THE VEHICLE MANUFACTURER'S ROOF LOAD LIMIT IS FOLLOWED UNLESS OTHERWISE SPECIFIED.

**DYNAMIC LOAD LIMIT:**

UP TO 96 Kg + 24 Kg = UP TO 120 Kg  
 UP TO 212 lbs + 53 lbs = UP TO 265 lbs

**VEHICLE MANUFACTURER'S ROOF LOAD LIMIT:**

UP TO 96 Kg + 24 Kg = UP TO 120 Kg  
 UP TO 212 lbs + 53 lbs = UP TO 265 lbs

**UNDERBAR SPACING:**

| BAR NO.   | A | B | C | D | E | F | G |
|-----------|---|---|---|---|---|---|---|
| FRONT BAR |   |   |   |   |   |   |   |
| REAR BAR  |   |   |   |   |   |   |   |
| SPACING   |   |   |   |   |   |   |   |

View Fitting Chart

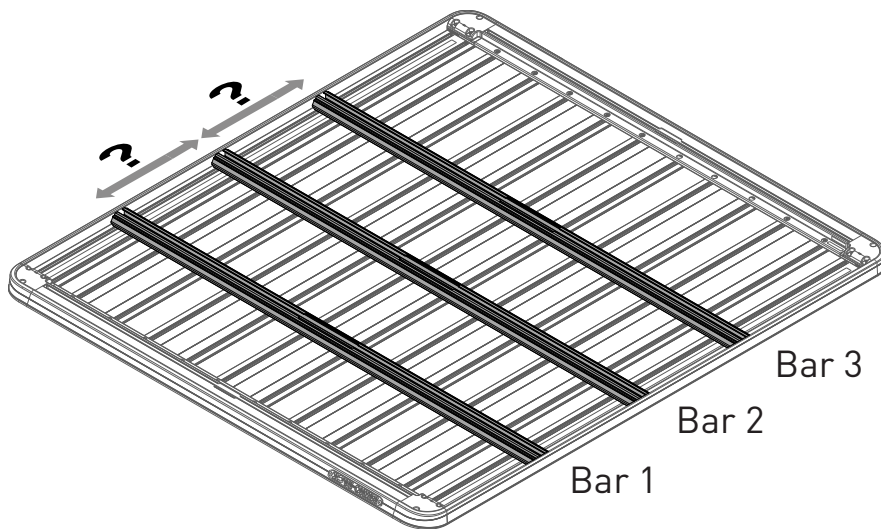

**8** For 5XXXX Series Platform

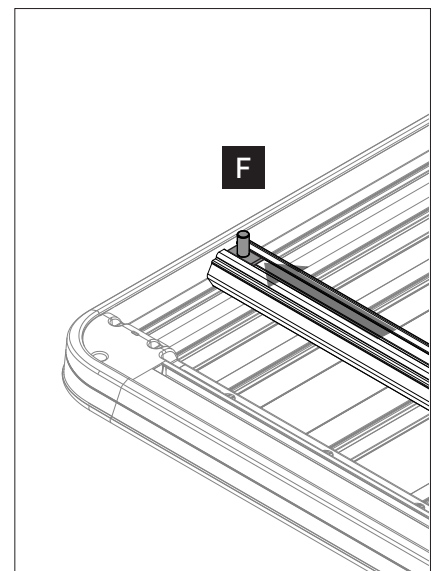
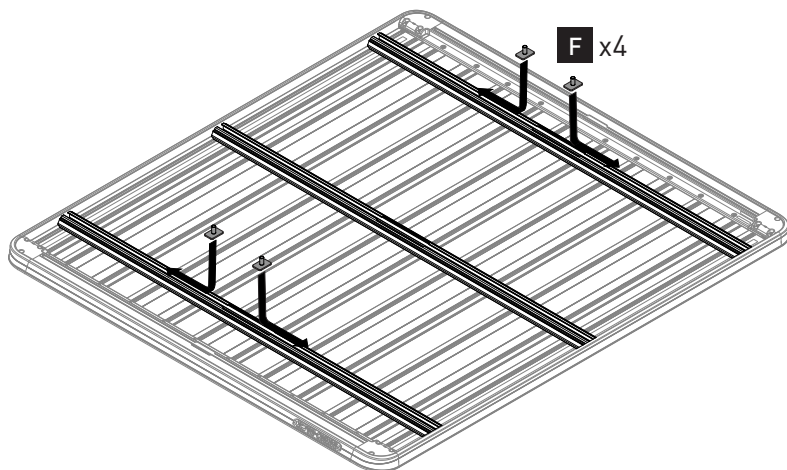

**9** For 5XXXX Series Platform

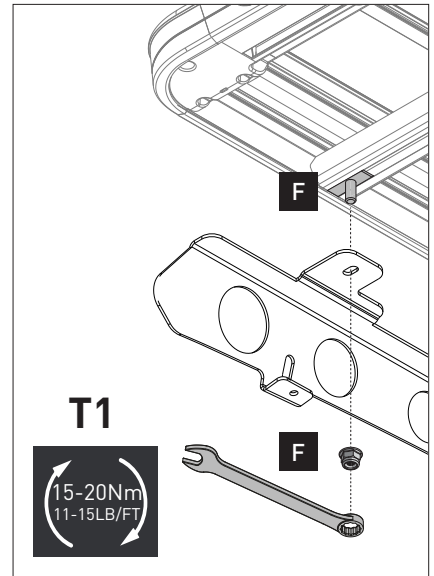
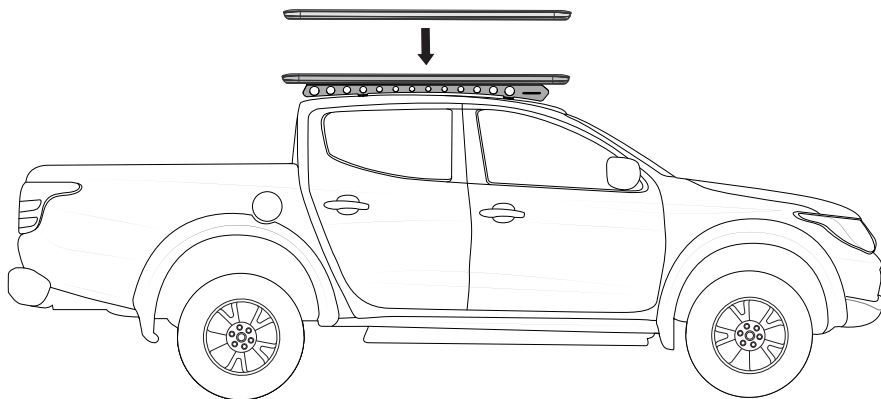

**10** For 4XXXX Series Platform

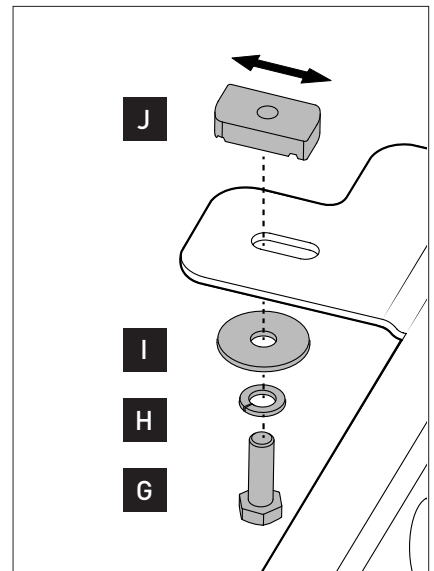
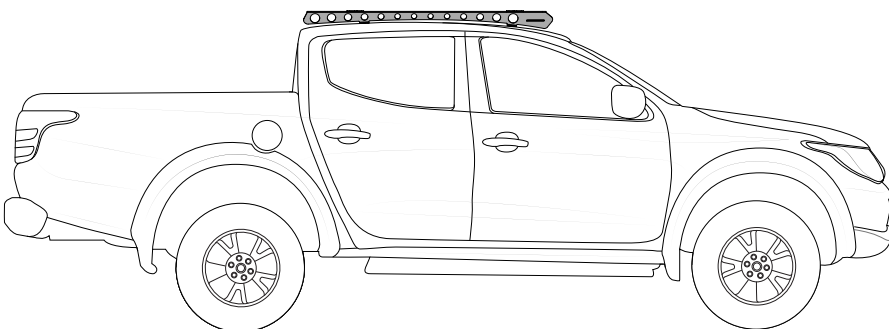

**11** For 4XXXX Series Platform

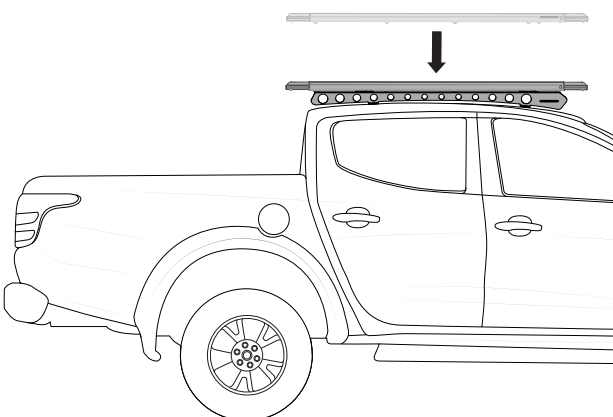

Ensure channel nut has rotated within Pioneer underbar and is fixing Pioneer securely.

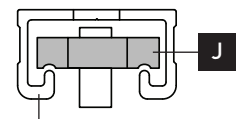

Pioneer underbar

