



# RHINO-RACK

**CONTROLLED**

## Iveco Daily QMFK15 Fitment

**Important:** Please read these instructions carefully prior to and during installation. Check the contents of kit before commencing fitment and report any discrepancies.

Item	Components	Dual Cab		Cab Chassis		Part No.
		VA Qty	HD Qty	VA Qty	HD Qty	
1	Vortex Crossbar	2	-	1	-	VA180S/B
2	Heavy Duty Crossbars	-	2	-	1	RB1800S/B
3	Quick Mount Roof Ditch Bracket	1	1	1	1	QMFK15
*4	Quick Mount HD Spacer 5mm	-	2	-	1	QMHD05
5	Leg and Base Kit	1	1	.5	.5	RLT600
6	Fitting Instructions	1	1	1	1	R1040

\* For use with Pioneer Tray/ Platform. Optional when using HD or Vortex Bars.

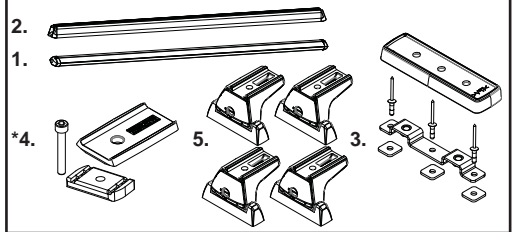

**Note:**  
All parts are sold as separate. Ensure you have the required kits to complete your fitment.

- Tools Required:**
- Masking tape
  - Cold Galvanising Paint
  - Vacuum
  - Pneumatic Rivet Gun
  - Cotton buds
  - Tape measure
  - Power Drill
  - 5mm drill bit and Stop
  - Marking Pen
  - Scrape of similar

## Instructions

**1** Apply masking tape along the Ditch on the roof of the vehicle in the approximate working area. Measure forward from the very rear of the Cab 430mm and create a reference with a marker. **For Dual Cabs only:** Measure forward a further 615mm and create an additional reference.

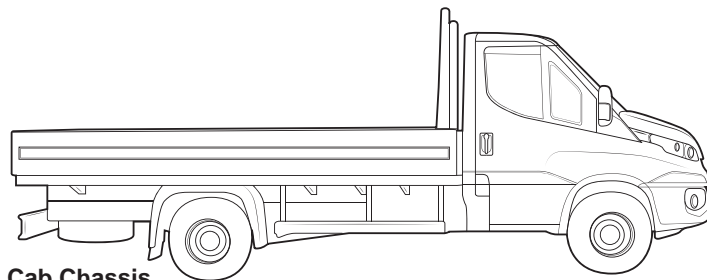

Cab Chassis

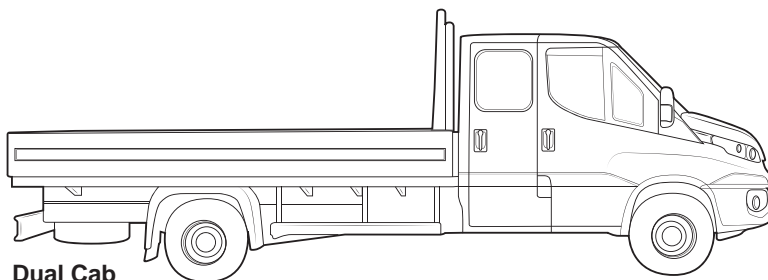
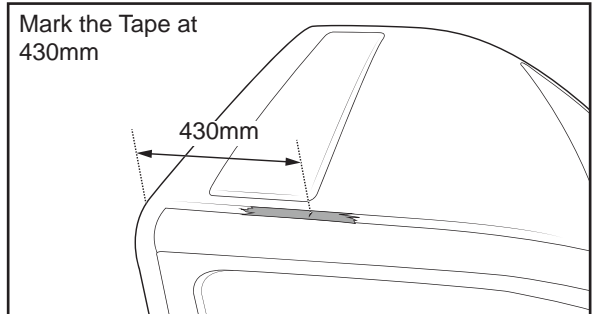

Dual Cab

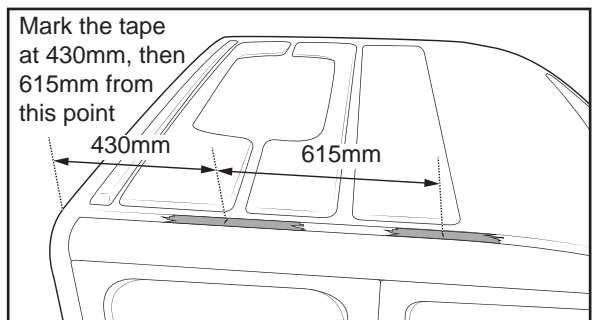

**2** Place the QMFK centre hole on the references made previous. Mark each Rivet Hole on the bracket onto the

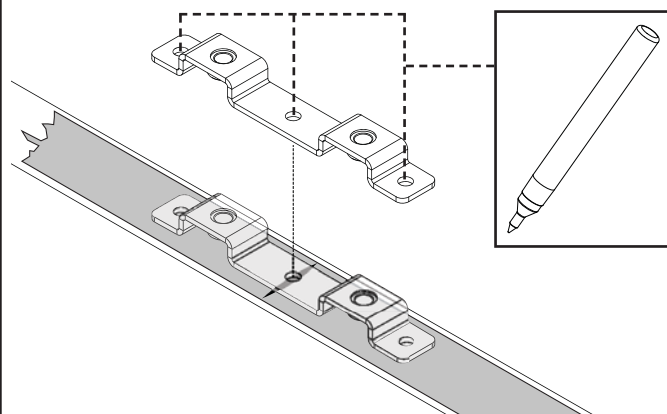

**3** Remove the Brackets and Drill through the Rivet reference marks. Use a 5mm Drill Bit with a Drill Stop set to 5mm.

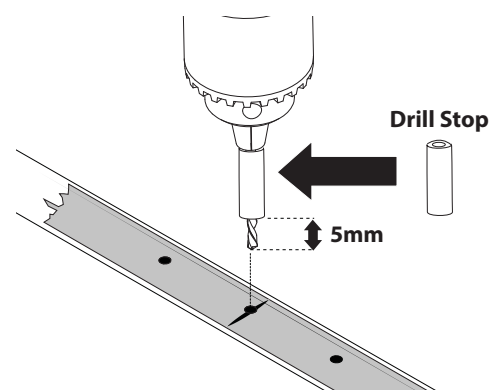



# Iveco Daily QMFK15 Fitment

**4** Vacuum any swarf from the roof.

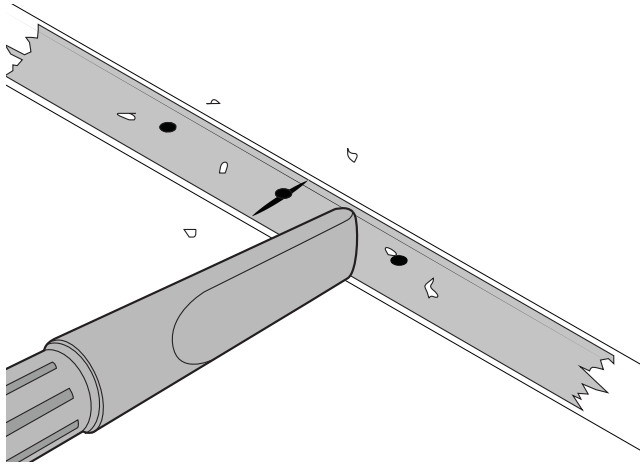

**5** Remove the Tape and using Cold Galvanising Paint, coat all drilled holes and any exposed body work.

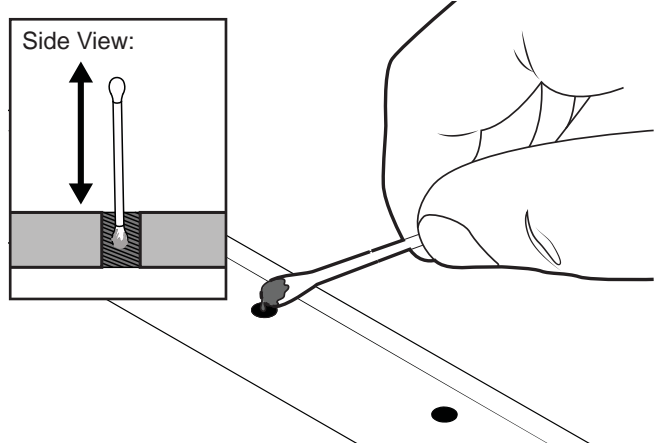

**6** Peel off the one side of backing tape on the Butyl Patches provided. Place these carefully over all holes drilled. Remove the top layer of backing tape as shown.

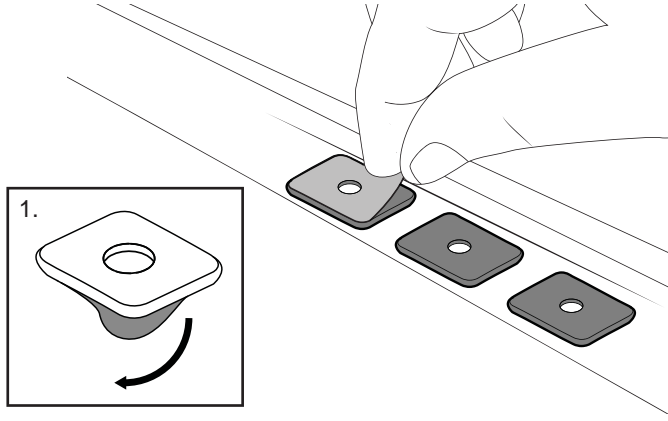

**7** Press the Ditch Brackets into position over the drilled holes. Using a Pneumatic Rivet Gun, fix the Brackets in place with Rivets provided. Be sure Brackets are aligned correctly.

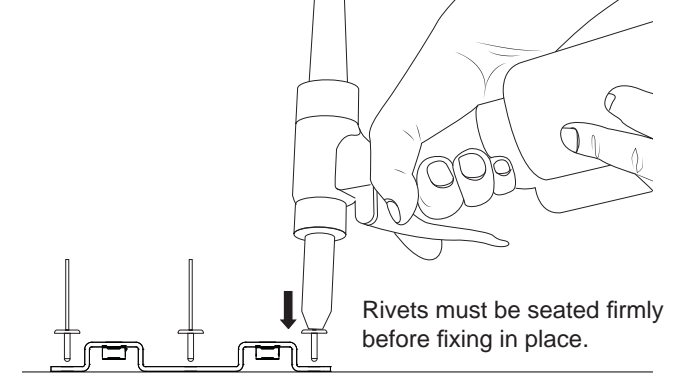

**Note** Install leg kits as per corresponding instructions.

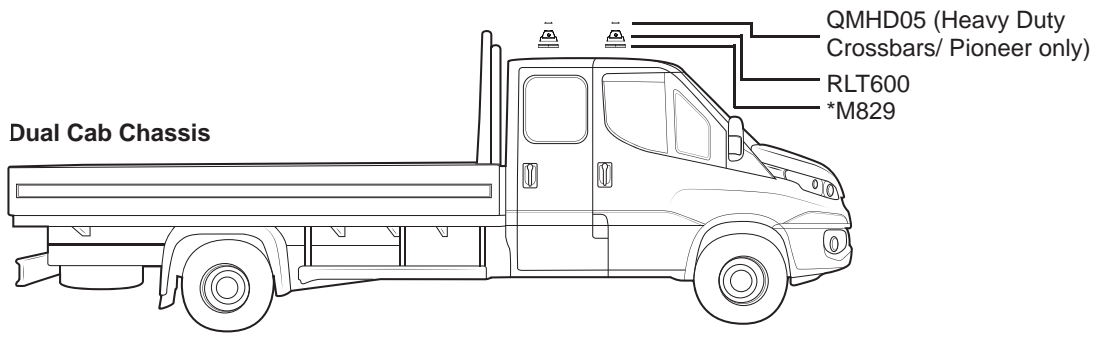
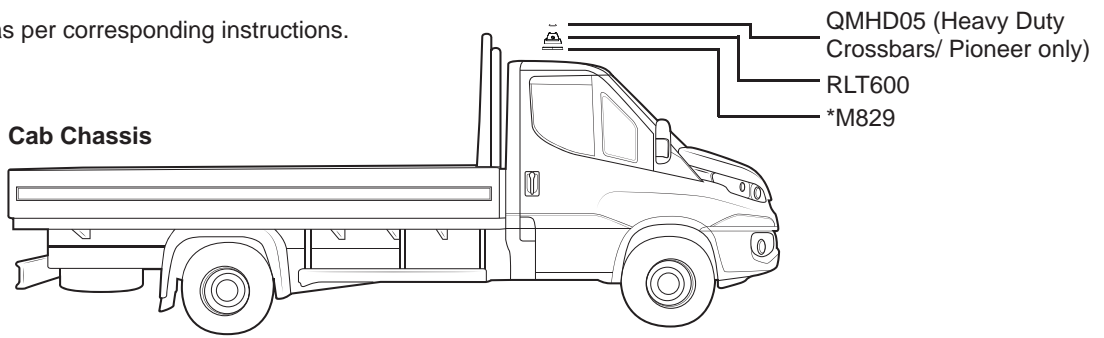

**\*NOTE:** M829 will sit on top of the installed Bracket. The Gasket will cover exposed areas of the Bracket and Ditch Mould.

Rhino-Rack  
3 Pike Street, Rydalmere,  
NSW 2116, Australia.  
(Ph) (02) 9638 4744  
(Fax) (02) 9638 4822

Document No: R1040  
Prepared By: Kayle Everett  
Authorised By: Chris Murty

Fit Time: 1 Hour  
Issue No: 01  
Issue Date: 31/05/16

These instructions remain the property of Rhino-Rack Australia Pty. Ltd. and may not be used or changed for any other purpose than intended.