

VEHICLE	PIONEER SIZE	CONNECTOR	HEIGHT ADDED (mm / in)
SAMMITR Gen 1 / 2 Dual Cab Canopy	52109	RLTP	

IMPORTANT NOTES	To suit Dual Cab utes
-----------------	-----------------------

REGION	AUS	NZ	USA	CA	SA	UK	EU	ZA
AVAILABILITY	✓	✓	x	x	x	x	x	x
RUNNING DATES	08/16 -	08/16 -	-	-	-	-	-	-

UNDERBAR SPACING

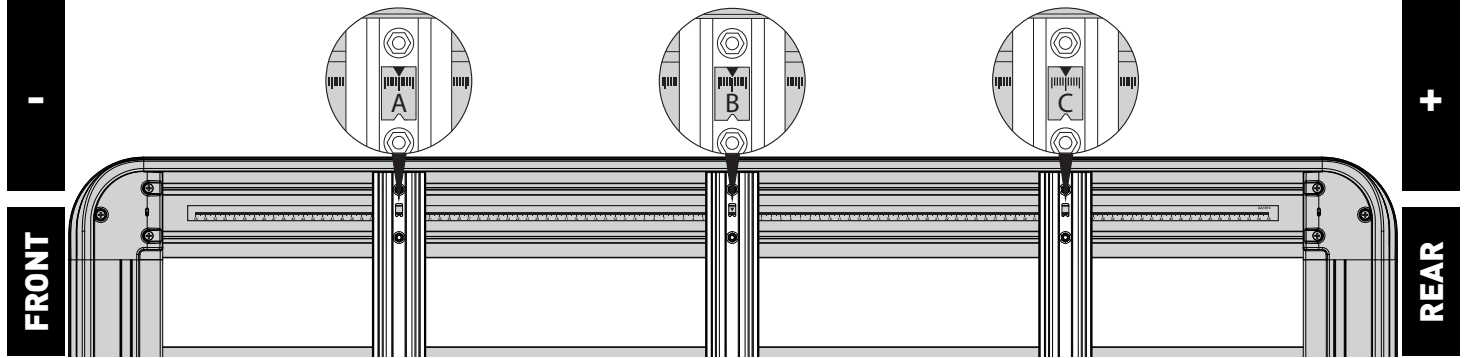

BAR NO.	A	B	C	D	E	F	G
DIMENSION (CM)	-23	0	51.5				
SPACERS REQ'D	VA-FK1 / RTW01		VA-FK1 / RTW01				
CONNECTOR	RLTP		RLTP				

VEHICLE LOAD LIMIT (VLL) (kg / lbs)	SYSTEM WEIGHT (SW) (kg / lbs)	ON-ROAD CARGO ALLOW. (OR)	OFF-ROAD CARGO ALLOW. (OFR)
Up to 100 / 220.5*	22 / 48.5	OR = VLL - SW	OFR = OR / 1.5

***CHECK YOUR VEHICLE OWNERS HAND BOOK FOR VEHICLE MAXIMUM CARRYING CAPACITY. PLEASE ENSURE YOU USE THE VEHICLE MANUFACTURERS MAXIMUM ROOF ALLOWANCE IF IT IS LOWER THAN THE FIGURE LISTED IN THIS INSTRUCTION.**

NOTES FOR DEALERS / FITTERS

It is your responsibility to ensure these fitting instructions are given to the end user or client.

Document No: R2462
 Issue No: 1
 Issue Date: 19-Mar-20

These instructions remain the property of Rhino-Rack Australia Pty. Ltd. and may not be used or changed for any other purpose than intended.