

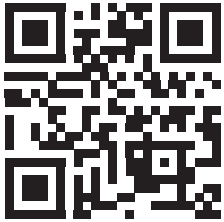





VEHICLE		BAR TYPE		CONNECTOR		BED HEIGHT ADDED (mm/in)		
JEEP Gladiator JT 6ft4		Reconn-Deck		RTD4		280/11		
VEHICLE NOTES								
REGION	AUS	NZ	USA	CA	SA	UK	EU	ZA
AVAILABILITY	✓	✓	✓	✓	x	x	x	x
RUNNING DATES	2020 -	2020 -	2020 -	2020 -	-	-	-	-

VISIT THE ONLINE CALCULATOR FOR CURRENT SYSTEM LOAD LIMIT DATA



DYNAMIC LOAD LIMIT (ON AND OFF-ROAD):
 *USE THE VEHICLE MANUFACTURER'S MAXIMUM TRACK ALLOWANCE IF IT IS LOWER THAN THE FIGURE LISTED

 CARGO	 SYSTEM WEIGHT	 LOAD LIMIT	OR	 Max kg
UP TO 136 Kg 300 lbs	+	14 Kg 31 lbs	=	UP TO 150 Kg 331 lbs
				*VEHICLE MANUFACTURER'S TRUCK BED UTILITY TRACK LOAD LIMIT

TOTAL STATIC LOAD LIMIT: UP TO 375kg / 827lbs

BASE

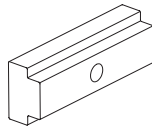
TRACK NUTS	PART DETAILS	
	PART NO	RD-FK1
	KIT QTY	1

BAR

CROSS BAR	PART DETAILS	
 RECONN-DECK	PART NO	RDB150
	QTY	2

ACCESSORY

NS BAR	PART DETAILS	
	PART NO	-
	QTY (pair)	-
	Recommended NS Bar setup is included in the SYSTEM WEIGHT above. Refer to NS BAR Instructions for custom setups.	

ONLY COMPATIBLE WITH RECONN-DECK BARS

RECOMMENDED TOWER SPACING

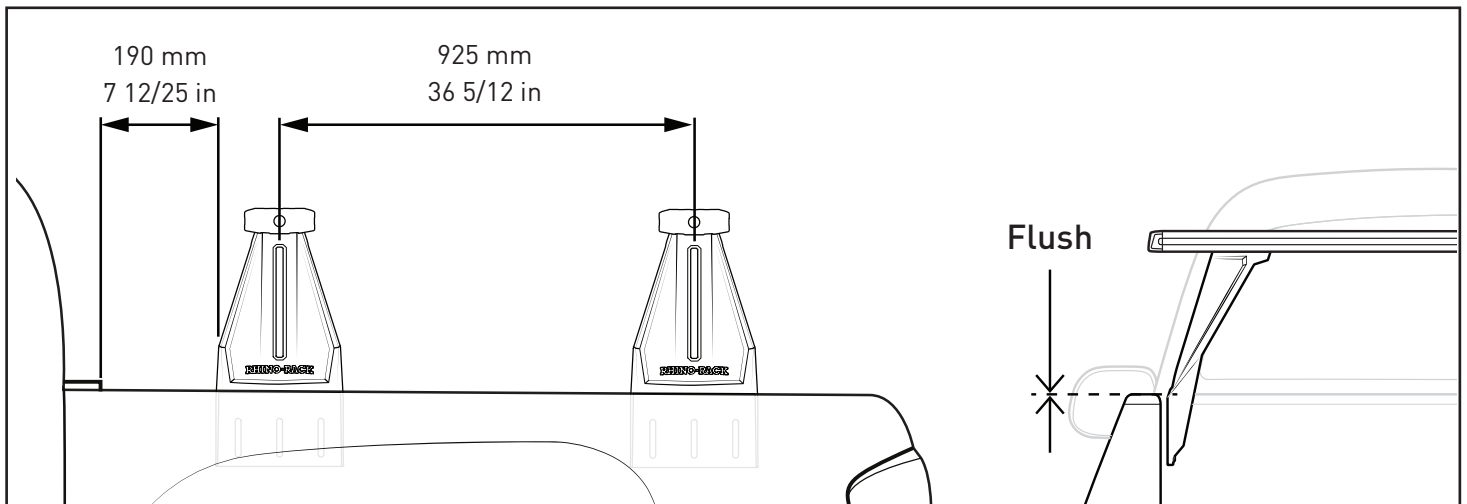

After positioning Towers, return to Reconn-Deck Tower Instruction.

NOTES FOR DEALERS / FITTERS

It is your responsibility to ensure these fitting instructions are given to the end user or client.