

CONTROLLED
RHINO-RACK RR-21
AUSTRALIA



HI-TECH GLASS REINFORCED NYLON LEGS WITH STRUCTURAL GRADE ANODISED OR POWDER COATED ALUMINIUM H SECTION BAR, THAT WILL GIVE YOU MANY YEARS OF TROUBLE FREE USAGE.

THANKYOU FOR PURCHASING A RHINO-RACK TO SUIT A HOLDEN VT WAGON

YOUR RHINO-RACK IS DESIGNED AND MANUFACTURED IN AUSTRALIA TO MEET THE STRINGENT REQUIREMENTS OF AUSTRALIAN STANDARD AS1235-91. ONLY USE RHINO-RACK APPROVED ACCESSORIES.

1. The black stripping on the VT roof provides easy fitting of the roof racks. Remove the rectangular nuts from the base of the nylon legs. Place these nuts in the windows of the tracks, which are found at the front and rear of the black stripping. Slide nuts into desired position and attach leg bolts to the nuts using a 5mm allen key, do not tighten
2. Loosen the channel nut on top of the leg support assembly to allow it to slot into the underside of the crossbar. Rotate the bolt to allow the channel nut to lock into position. If the channel nut does not rotate into position, loosen the bolt and repeat. **It is essential that the channel nut rotates into position.**
3. Ensure bar overhang is equal both sides. Tighten crossbar to leg assembly using 5/8 ring spanner. Attach leg assembly to tracks using 5mm allen key provided.
4. Insert the rubber buffer strip. Hint: place one edge of the rubber buffer strip into the top of the crossbar and apply a downward force to the other edge. Ensure that the rubber buffer strip is seated firmly into the crossbar.
5. Using a rubber mallet, knock the four bar end caps on to the ends of the crossbars.

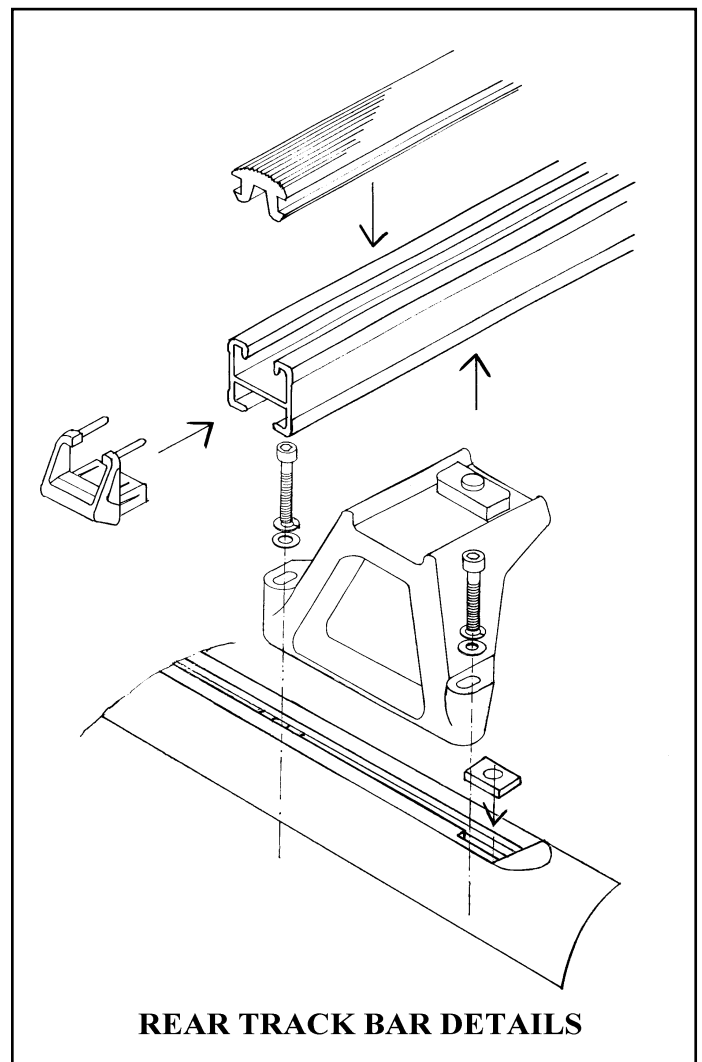

Please Note: When more than two crossbars are to be fitted, Rhino-Rack leg height spacers (LHS) may be required to level crossbar height due to roof curvature. Only Rhino-Rack approved accessories should be attached to bar systems. List available from Rhino-Rack or your local distributor.

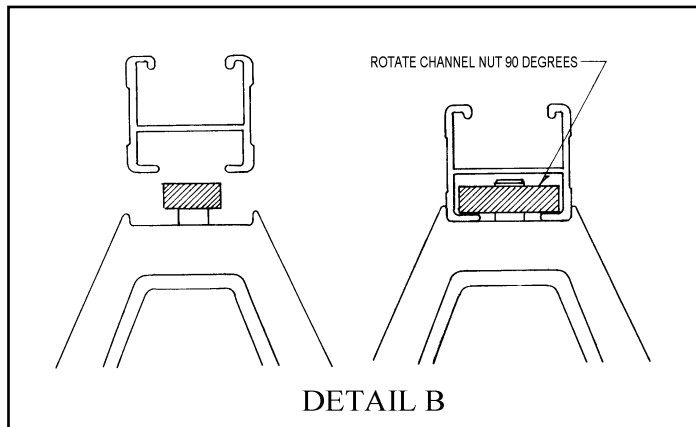

RECOMMENDATIONS

Please refer to your vehicle manufacturers operating manual for maximum roof load rating. **Please note that the vehicles roof load rating may be less than the trackmount bar load rating.**

It is essential that all bolt connections are checked after driving a short distance when you first install your Rhino-Rack. Bolt connections should be checked again at regular intervals (probably once a week is enough, depending on road conditions, usage, loads and distances traveled). You should also check the roof bars each time they are refitted.

Crossbars and accessories should be cleaned and all screw threads should be lubricated at regular intervals. Rhino-Rack offers a 12-month warranty to the original purchaser of the Rhino Sportz VT System and Accessories. Rhino-Rack cannot be held responsible for incorrect mounting of the Fixed Mount System or for usage that exceeds vehicle and production tolerances.

Make sure to fasten your load securely. Please ensure that all loads are evenly distributed and that the centre of gravity is kept as low as possible. **Use only non-stretch fastening ropes or straps.**

SENSITIVITY TO CROSSWINDS, BEHAVIOUR IN CURVES AND BRAKING

The handling characteristics of the car changes considerably, when you transport a load on the roof. For safety reasons, we recommend you exercise extreme care when transporting wind-resisting loads. Special consideration must be taken into account when braking.

PLEASE REMOVE CROSSBARS WHEN PUTTING VEHICLE THROUGH AN AUTOMATIC CAR WASH.

LOAD RATINGS

Maximum permissible load is 100kg per pair of roof bars. (Include the weight of the roof bars, 7kg.) When roof bars are to be used in extreme off-road conditions please build a safety factor of 1.5 into this load limit (67kg per pair). Although roof bars are tested and approved to AS1235-91, Australian road conditions can be much more rigorous. Addition of extra roof bars has proven to be the most successful way to minimize vehicle roof turret deformation. However, increasing the number off crossbars does not increase the vehicles maximum permissible roof loading. Note for dealers and fitters. It is your responsibility to ensure instructions are given to the end user or client.

Manufactured by

Rhino- Rack

17 Euston St. Rydalmere, NSW 2116, Australia

(Ph) 02 9638 4744 (Fax) 02 9638 4822

RHINO-RACK	No: RR21
Prepared By: MARTIN FERRIER	Issue No: 02
Authorized By: GARY ENGLAND	Date: 19.01.2000