

VEHICLE	PIONEER SIZE	CONNECTOR	HEIGHT ADDED (mm / in)
ISUZU D-Max LS-U/LS-M/X-Runner TF Pickup/Ute 4dr	52100	RCH4	

IMPORTANT NOTES	Do not operate sunroof
-----------------	------------------------

REGION	AUS	NZ	USA	CA	SA	UK	EU	ZA
AVAILABILITY	✓	✓	✗	✗	✗	✗	✗	✗
RUNNING DATES	06/12 -	06/12 -	-	-	-	-	-	-

**UNDERBAR SPACING**

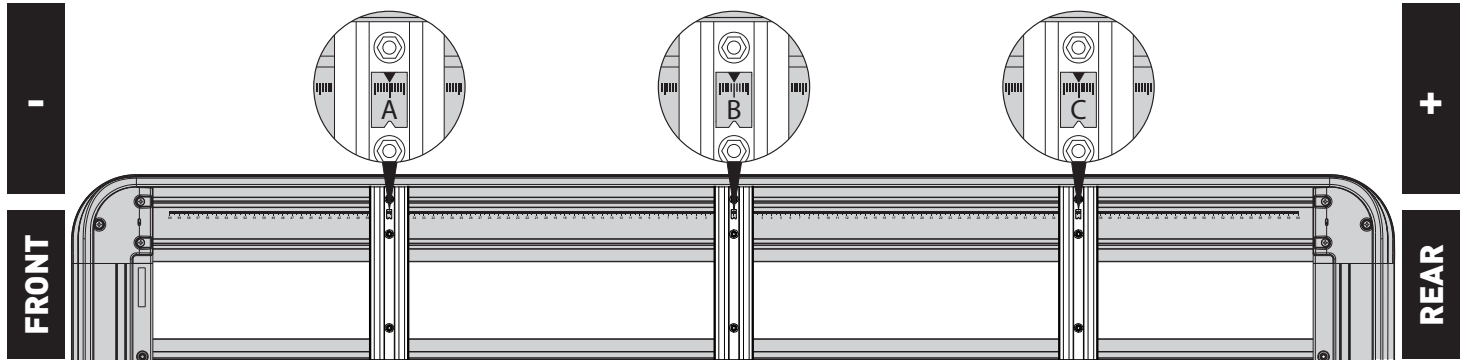

BAR NO.	A	B	C	D	E	F	G
DIMENSION (CM)	-33	0	52				
SPACERS REQ'D							
CONNECTOR	RCH		RCH				

VEHICLE LOAD LIMIT (VLL) (kg / lbs)	SYSTEM WEIGHT (SW) (kg / lbs)	ON-ROAD CARGO ALLOW. (OR)	OFF-ROAD CARGO ALLOW. (OFR)
Up to 100 / 220.5*	22 / 47.8	OR = VLL - SW	OFR = OR / 1.5

**\*CHECK YOUR VEHICLE OWNERS HAND BOOK FOR VEHICLE MAXIMUM CARRYING CAPACITY. PLEASE ENSURE YOU USE THE VEHICLE MANUFACTURERS MAXIMUM ROOF ALLOWANCE IF IT IS LOWER THAN THE FIGURE LISTED IN THIS INSTRUCTION.**

**NOTES FOR DEALERS / FITTERS**  
It is your responsibility to ensure these fitting instructions are given to the end user or client.

Document No: R1992  
Issue No: 3  
Issue Date: 18-Feb-20

These instructions remain the property of Rhino-Rack Australia Pty. Ltd. and may not be used or changed for any other purpose than intended.