

VEHICLE	PIONEER		CONNECTOR		HEIGHT ADDED (mm/in)			
MERCEDES BENZ Metris W447 Raised Rail	52120		SX100		121 / 4.8			
VEHICLE NOTES	-							
REGION	AUS	NZ	USA	CA	SA	UK	EU	ZA
AVAILABILITY	x	x	✓	✓	x	x	x	x
RUNNING DATES	-	-	2016 -	2016 -	-	-	-	-

VISIT THE ONLINE
LOAD LIMIT
CALCULATOR FOR
CURRENT LOAD DATA



DYNAMIC LOAD LIMIT (ON AND OFF-ROAD):
 *USE THE VEHICLE MANUFACTURER'S MAXIMUM ROOF ALLOWANCE IF IT IS LOWER THAN THE FIGURE LISTED

 CARGO
 UP TO **54 Kg**
119 lbs

+

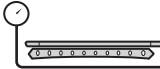

 SYSTEM WEIGHT
 UP TO **26 Kg**
57 lbs

=

 LOAD LIMIT
 UP TO **80 Kg**
176 lbs

OR

 Max kg
 *VEHICLE
 MANUFACTURER'S
 ROOF LOAD LIMIT

TOTAL STATIC LOAD LIMIT: UP TO 200 Kg / 441 lbs*

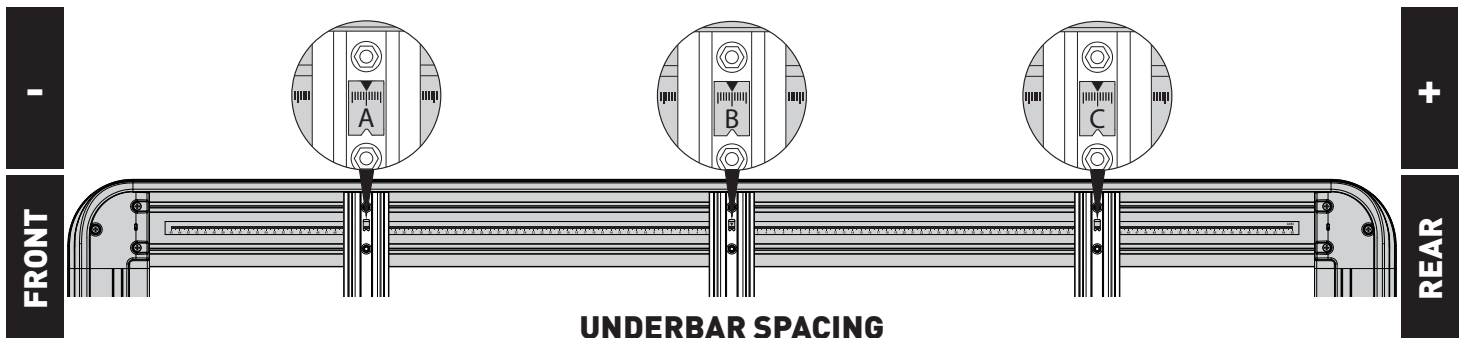

BAR NO.	A	B	C	D	E	F	G
DIMENSION (CM)	-53.6	0	53.6				
SPACERS REQ'D							
CONNECTOR	SX100		SX100				

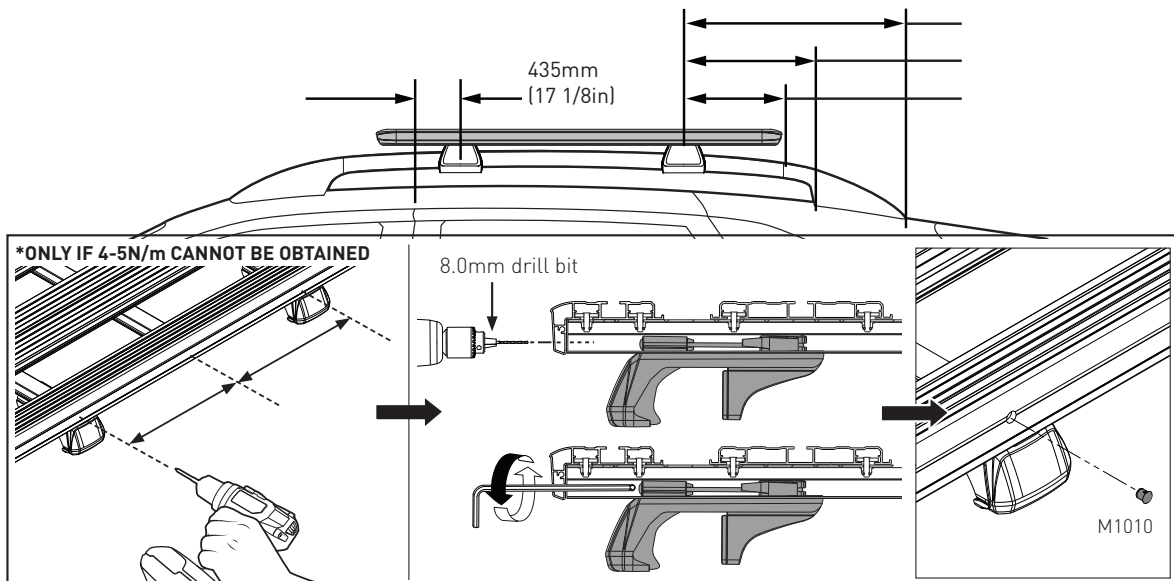

NOTES FOR DEALERS / FITTERS

It is your responsibility to ensure these fitting instructions are given to the end user or client.

Document No: R2859
 Issue No: 1
 Issue Date: 01-Jul-21