

VEHICLE	PIONEER		CONNECTOR		HEIGHT ADDED (mm/in)			
LEXUS GX 460 4WD/SUV Raised Rail 4 dr	52102		SX100					
VEHICLE NOTES	- Do not operate sunroof							
REGION	AUS	NZ	USA	CA	SA	UK	EU	ZA
AVAILABILITY	x	x	✓	✓	x	x	x	x
RUNNING DATES	-	-	2010 -	2010 -	-	-	-	-

VISIT THE ONLINE  
LOAD LIMIT  
CALCULATOR FOR  
CURRENT LOAD DATA



**DYNAMIC LOAD LIMIT (ON AND OFF-ROAD):**  
 \*USE THE VEHICLE MANUFACTURER'S MAXIMUM ROOF ALLOWANCE IF IT IS LOWER THAN THE FIGURE LISTED

  
 CARGO  
 UP TO **52 Kg**  
**115 lbs**

+

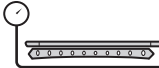
  
 SYSTEM WEIGHT  
 UP TO **28 Kg**  
**62 lbs**

=

  
 LOAD LIMIT  
 UP TO **80 Kg**  
**176 lbs**

OR

  
 Max kg  
**\*VEHICLE  
MANUFACTURER'S  
ROOF LOAD LIMIT**

**TOTAL STATIC LOAD LIMIT: UP TO 200 Kg / 441 lbs\***

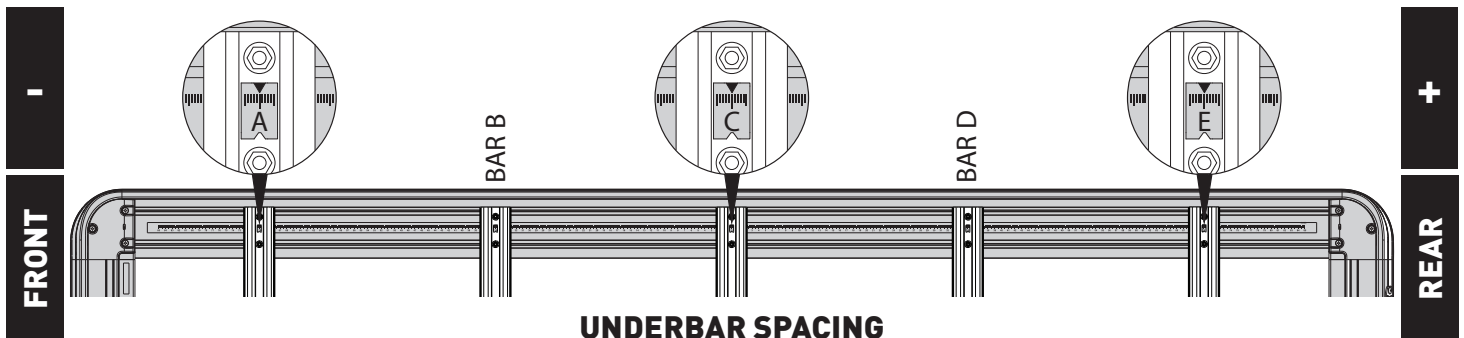

BAR NO.	A	B	C	D	E	F	G
DIMENSION (CM)	-40.5	-30	4.2	38.4	45.5		
SPACERS REQ'D							
CONNECTOR	SX				SX		

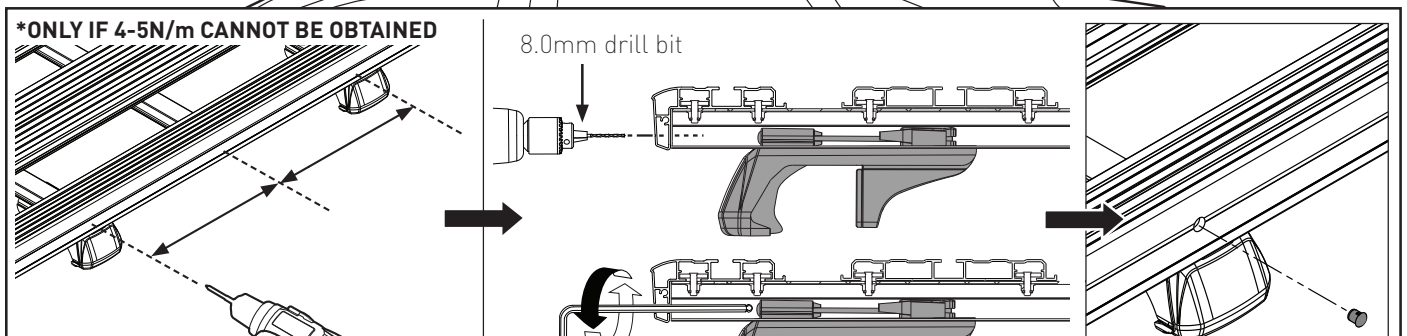
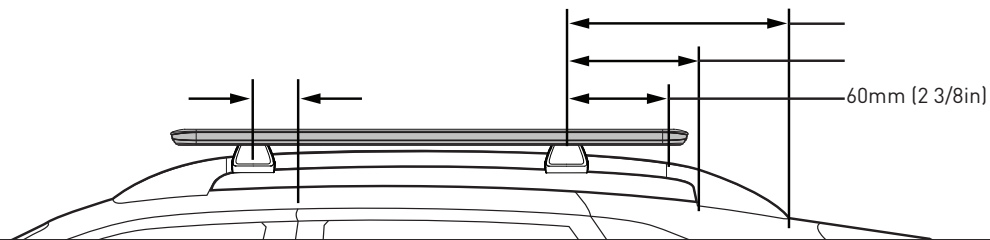

### NOTES FOR DEALERS / FITTERS

It is your responsibility to ensure these fitting instructions are given to the end user or client.

Document No: R2687  
 Issue No: 2  
 Issue Date: 19-Mar-21