

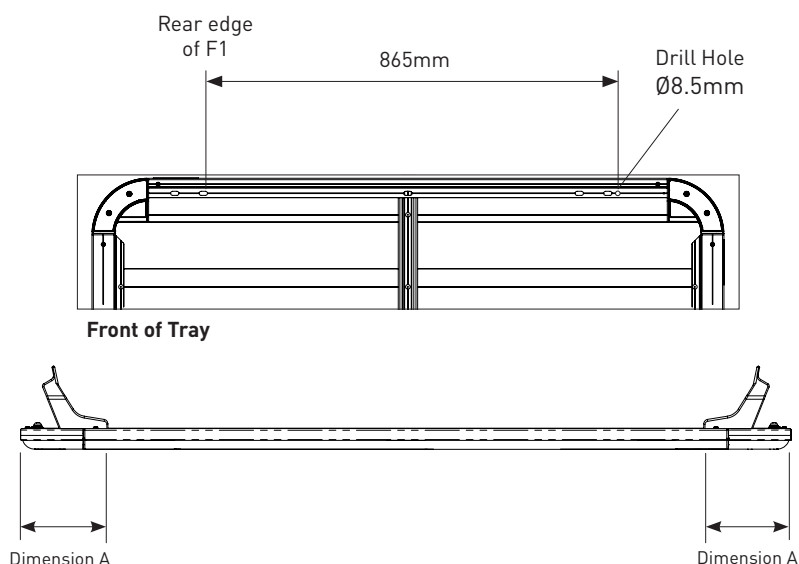

Pioneer Platform / Pioneer Tray / Pioneer Tradie

Fitting Chart - ISUZU DMAX Gen 3 4dr Ute Double Cab Bare Roof MAZDA BT50 Gen 3 4dr Ute Double Cab Bare Roof

PIONEER 42109B (1328 x 1236mm)
PIONEER 45109B (1328 x 1236mm)



Front Crossbar			Rear Crossbar		
Front Slot	Dim. A	Leg Height Spacer	Rear Slot	Dim. A	Leg Height Spacer
F1	=	QMHD05	Drill	=	QMHD05

Country	Vehicle	Running Date	Vehicle Load Rating (kg / lbs)	Fit Kit
Australia & NZ	ISUZU DMAX Gen 3 4dr Ute Double Cab Bare Roof	2020 - on	Up to 100 / 220*	1 x RCP71-BK 1 x RCH4 2 x QMHD05
	MAZDA BT50 Gen 3 4dr Ute Double Cab Bare Roof	2020 - on	(system weight not included in figure)	

***CHECK YOUR VEHICLE OWNERS HAND BOOK FOR VEHICLE MAXIMUM CARRYING CAPACITY. PLEASE ENSURE YOU USE THE VEHICLE MANUFACTURERS MAXIMUM ROOF ALLOWANCE IF IT IS LOWER THAN THE FIGURE LISTED IN THIS INSTRUCTION.**

Rhino-Rack

22A Hanson Pl, Eastern Creek,
NSW 2766, Australia.
(Ph) (02) 8846 1900

Document No: R2684
Issue No: 01
Issue Date: 19/11/2020

These instructions remain the property of Rhinorack Australia Pty Ltd and may not be used or changed for any other purpose than intended.