

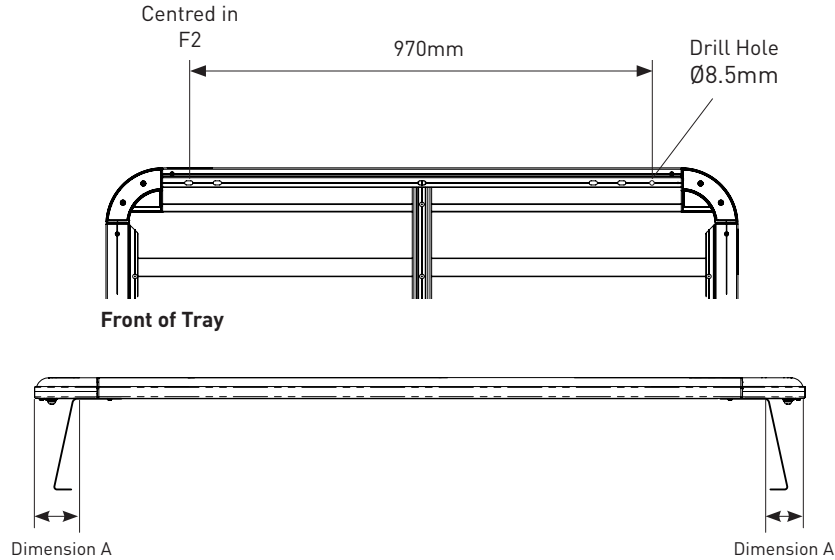

## Pioneer Platform / Pioneer Tray / Pioneer Tradie

**Fitting Chart - ISUZU DMAX Gen 3 4dr Ute Double Cab Bare Roof (with Backbone)  
ISUZU DMAX Gen 3 X-Terrain 4dr Ute Double Cab Flush Rail (with Backbone)  
MAZDA BT50 Gen 3 4dr Ute Double Cab Bare Roof (with Backbone)**

**PIONEER 42109B** (1328 x 1236mm)  
**PIONEER 45109B** (1328 x 1236mm)



Front Crossbar			Rear Crossbar		
Front Slot	Dim. A	Leg Height Spacer	Rear Slot	Dim. A	Leg Height Spacer
F2	=	N/A	Drill	=	N/A

Country	Vehicle	Running Date	Vehicle Load Rating (kg / lbs)	Fit Kit
Australia & NZ	ISUZU DMAX Gen 3 4dr Ute Double Cab Bare Roof	2020 - on	Up to 100 / 220* (system weight not included in figure)	1 x RIDB2
	ISUZU DMAX Gen 3 X-Terrain 4dr Ute Double Cab Flush Rail	2021 - on		
	MAZDA BT50 Gen 3 4dr Ute Double Cab Bare Roof	2020 - on		
UK & EU	ISUZU DMAX Gen 3 4dr Ute Double Cab Bare Roof	2021 - on		

**\*CHECK YOUR VEHICLE OWNERS HAND BOOK FOR VEHICLE MAXIMUM CARRYING CAPACITY. PLEASE ENSURE YOU USE THE VEHICLE MANUFACTURERS MAXIMUM ROOF ALLOWANCE IF IT IS LOWER THAN THE FIGURE LISTED IN THIS INSTRUCTION.**

### Rhino-Rack

22A Hanson Pl, Eastern Creek,  
NSW 2766, Australia.  
(Ph) (02) 8846 1900

Document No: R2683  
Issue No: 01  
Issue Date: 11/05/2021

These instructions remain the property of Rhinorack Australia Pty Ltd and may not be used or changed for any other purpose than intended.