

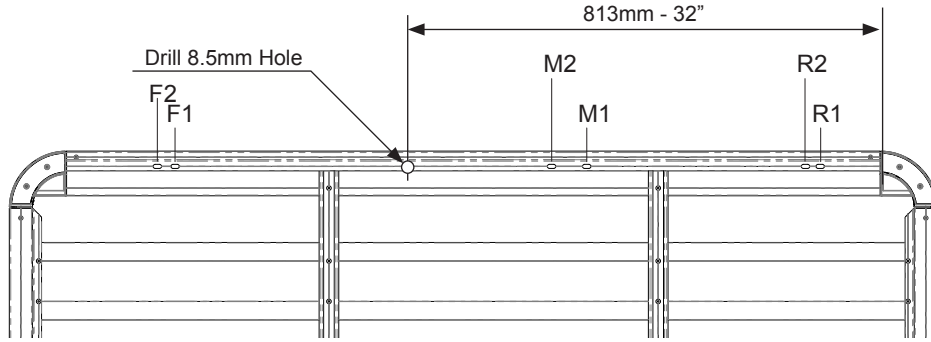

Fitting Chart - FORD Everest 3rd Gen 4dr SUV With Flush Rail 10/15 on.

PIONEER 41102 (1928 x 1236mm)
PIONEER 42102B (1928 x 1236mm)
PIONEER 45102B (1928 x 1236mm)



Front of Tray

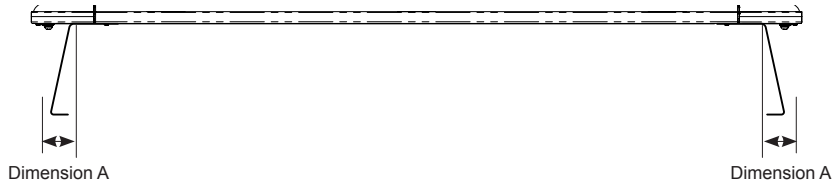

Front Crossbar			Middle Crossbar			Rear Crossbar			Approx. Overall Vehicle Height
Front Slot	Dim. A	Leg Height Spacer	Middle Slot	Dim. A	Leg Height Spacer	Rear Slot	Dim. A	Leg Height Spacer	
F2	EQUAL		Drill 813mm from Rear	EQUAL		R1	EQUAL		

Country	Vehicle	Running Date	Vehicle Load Rating (kg / lbs)	Fit Kit	Notes
Australia ,NZ & ZA	FORD Everest 3rd Gen 4dr SUV With Flush Rail removed on 10/15 on, with Backbone.	11/04 - 12/14	100 / 220	RFEB1	Fit Backbone system to vehicle before fitting Pioneer Can be fitted to all Vehicle roof variations Requires factory roof rail removal

Rhino-Rack
 3 Pike Street, Rydalmere,
 NSW 2116, Australia.
 (Ph) (02) 9638 4744
 (Fax) (02) 9638 4822

Document No: R1447
 Prepared By: Kayle Everett
 Authorised By: Chris Murty

Issue No: 1
 Issue Date: 09/08/2017

These instructions remain the property of Rhinorack Australia Pty Ltd and may not be used or changed for any other purpose than intended.