

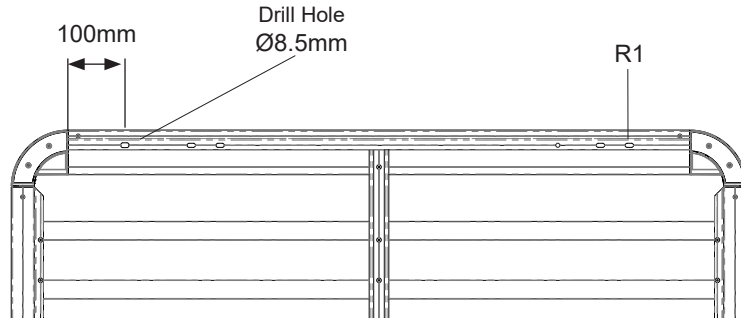

Fitting Chart - MAZDA BT50 4dr Ute Dual Cab (with Backbone)

- PIONEER 41100** (1528 x 1236mm)
- PIONEER 42100B** (1528 x 1236mm)
- PIONEER 45100B** (1528 x 1236mm)



Front of Tray



Front Crossbar			Rear Crossbar			Approx. Overall Vehicle Height
Front Slot	Dim. A	Leg Height Spacer	Rear Slot	Dim. A	Leg Height Spacer	
Drill Hole Ø8.5mm	EQUAL	N/A	R1	EQUAL	N/A	

Country	Vehicle	Running Date	Vehicle Load Rating (kg / lbs)	Fit Kit
Australia & NZ	MAZDA BT50 4dr Ute Dual Cab	11/11 - on	Up to 100 / 220* (system weight not included in figure)	1 × RTS554 1 × RFRB1

Internal Note: Identical vehicle/fitment to R1078 - Ford Ranger 4dr Ute Double Cab - RLT600 (10/11 - on)

***CHECK YOUR VEHICLE OWNERS HAND BOOK FOR VEHICLE MAXIMUM CARRYING CAPACITY. PLEASE ENSURE YOU USE THE VEHICLE MANUFACTURERS MAXIMUM ROOF ALLOWANCE IF IT IS LOWER THAN THE FIGURE LISTED IN THIS INSTRUCTION.**

Rhino-Rack
 22A Hanson Pl, Eastern Creek,
 NSW 2766, Australia.
 (Ph) (02) 8846 1900

Document No: R1079
 Issue No: 2
 Issue Date: 14/10/2020

These instructions remain the property of Rhinorack Australia Pty Ltd and may not be used or changed for any other purpose than intended.