

TRUCK BED TOWER FITTING SUPPLEMENT

RECONN-DECK + PIONEER

VEHICLE					PIIONEER	CONNECTOR	HEIGHT ADDED mm / in	
RAM 1500 Quad Cab w/ RAM BOX DS Gen 4 SHORT BED 5ft7					62113	RDT4	349 / 14	
REGION	AUS	NZ	USA	CA	SA	UK	EU	ZA
AVAILABILITY	✓	✓	✗	✗	✗	✗	✗	✗
RUN DATES	2009 -	2009 -	-	-	-	-	-	-
VEHICLE NOTES	Local registration date of the vehicle will differ from the original USA build date, after left to right hand drive conversion. If required, confirm the USA build generation of your vehicle with the local vehicle converter and/or original seller.							

VISIT THE ONLINE CALCULATOR FOR CURRENT SYSTEM LOAD LIMIT DATA



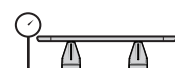

DYNAMIC LOAD LIMIT (ON AND OFF-ROAD):
***USE THE VEHICLE MANUFACTURER'S MAXIMUM TRACK ALLOWANCE IF IT IS LOWER THAN THE FIGURE LISTED**

 CARGO

 SYSTEM WEIGHT

 LOAD LIMIT



 Max kg

UP TO **95 Kg**
 209 lbs

+

25 Kg
 55 lbs

=

UP TO **120 Kg**
 264 lbs

*VEHICLE
 MANUFACTURER'S
 TRUCK BED UTILITY
 TRACK LOAD LIMIT

 TOTAL STATIC LOAD LIMIT: UP TO 300 Kg / 661 lbs*

BASE

RECOMMENDED TOWER SPACING

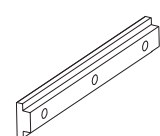
TRACK NUTS	
	
PART DETAILS	
PART NO	RD-FK3
QTY	1

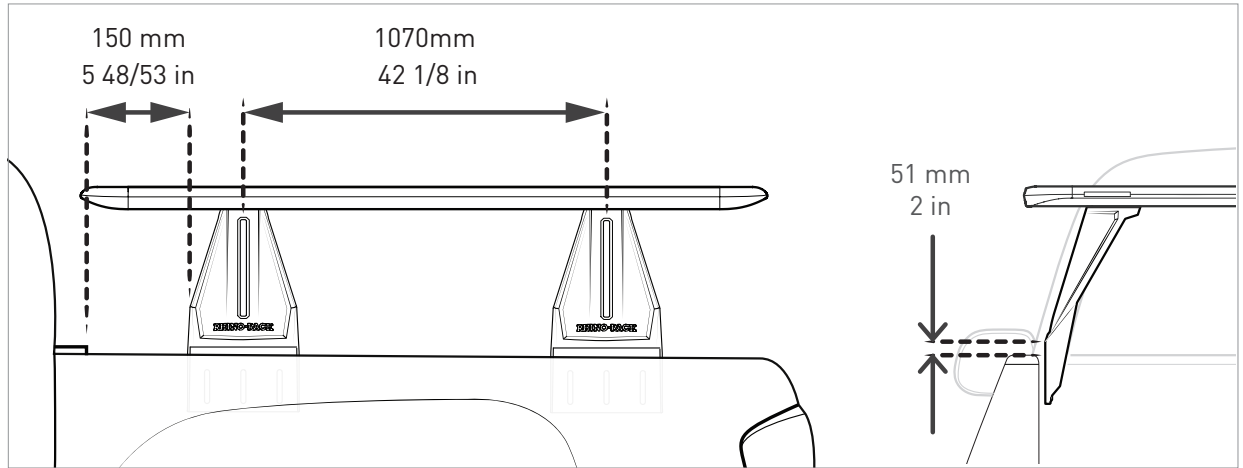

UNDERBAR SPACING

	FRONT + REAR						
BAR	A	B	C	D	E	F	G
DIMENSION [CM]	-53.5	0	53.5				
CONNECTOR	RDT		RDT				

After positioning Towers and Pioneer, return to Reconn-Deck Tower Instructions.

NOTES FOR DEALERS / FITTERS

It is your responsibility to ensure these fitting instructions are given to the end user or client.