

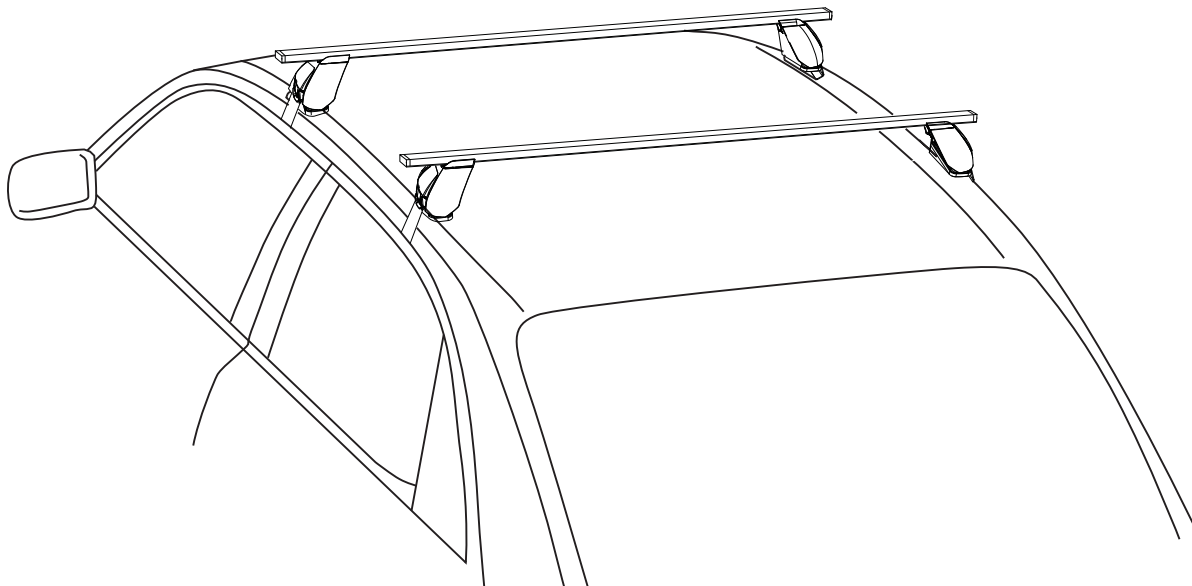

# RHINO-RACK

## Rhino 2500 series for Euro Crossbar.

- Important:**
- 1. Please refer to your fitting instruction to ensure that the roof racks are installed in the correct locations.
  - 2. Check the contents of kit before commencing fitment and report any discrepancies.
  - 3. Place these instructions in the vehicle's glove box after installation is complete.
  - 4. This kit also requires the DK fitting instructions
  - 5. These instructions must be followed for warranty to be upheld.



**Maximum carrying capacity: Up to 75kg (165lbs) evenly distributed over crossbars. Please refer to your vehicle manufacturers handbook and Rhino-Rack vehicle selector web page ([www.rhinorack.com/fit-my-car/select-vehicle](http://www.rhinorack.com/fit-my-car/select-vehicle)) for maximum roof loading. Always use the lower of the two figures.**

### Advisory:

It is essential that all bolt connections be checked after 48hrs from when you first install your crossbars. Bolt connections should be checked again at regular intervals (once a week is enough, depending on road conditions, usage, loads and distances travelled). You should also check the crossbars each time they are refitted. Make sure to fasten your load securely (see page 2 for advisory diagrams). Please ensure that all loads are evenly distributed and that the centre of gravity is kept as low as possible.

**Use only non-stretch fastening ropes or straps.**

### Load Ratings

When these roof racks are to be used on a vehicle that is driven off sealed roads, the manufacturer maximum roof load rating (to be found in the vehicle's User Manual) should be divided by a safety factor of **2**. For example, if the vehicle's maximum roof load rating is up to **75kg (165lbs)**, these racks, when fitted to this vehicle should have no more than 30kgs/66lbs loaded on them.

### Caution:

The handling characteristics of the vehicle changes when you transport a load on the roof. For safety reasons we recommend you exercise extreme care when transporting wind-resistant loads. Special consideration must be taken into account when cornering and braking. **Please remove crossbars when putting vehicle through an automatic car wash.**

**Note for Dealers and Fitters:** It is your responsibility to ensure instructions are given to the end user or client.

Rhino-Rack  
3 Pike Street, Rydalmere,  
NSW 2116, Australia.  
(Ph) (02) 9638 4744  
(Fax) (02) 9638 4822

Document No: RR226  
Prepared By: Kayle Everett  
Authorised By: Chris Murty

Fit Time: 30min  
Issue No: 07  
Issue Date: 06/03/2018

These instructions remain the property of Rhino-Rack Australia Pty. Ltd. and may not be used or changed for any other purpose than intended.



# Rhino 2500 series for Euro Crossbar.

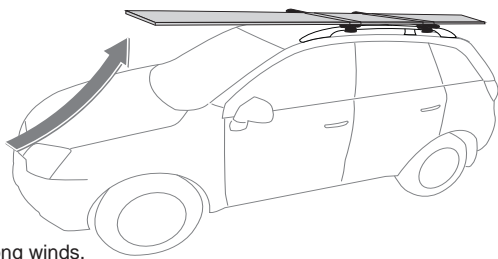

Be careful of strong winds.

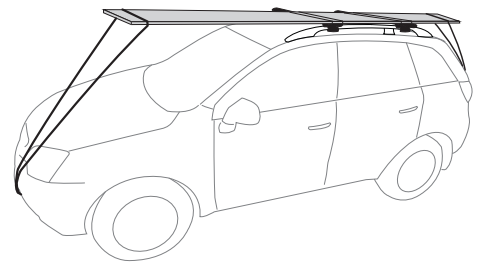
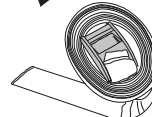

Secure long loads.

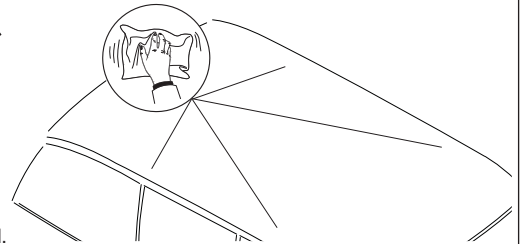
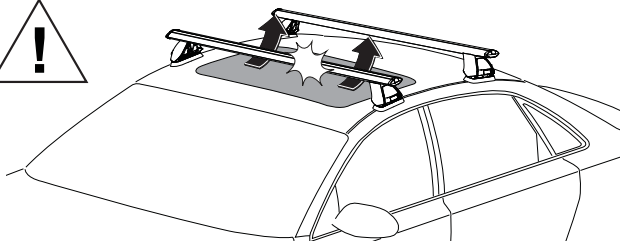

Wash Car by hand.

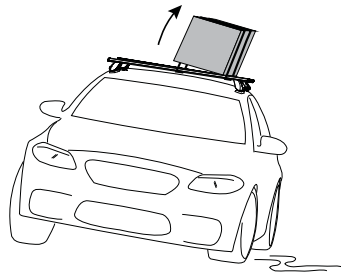
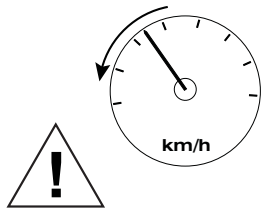

Reduce speeds.

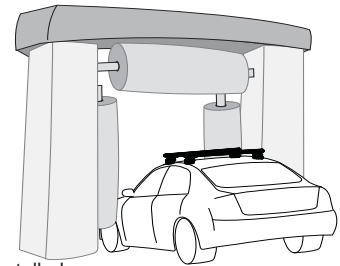

Do not use car wash with racks installed.



**NOT Recommended**

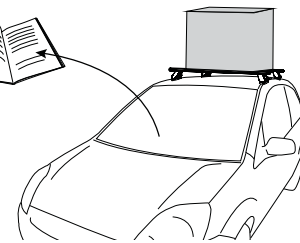
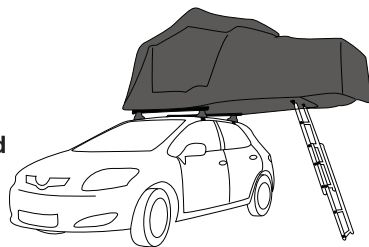

? kg/ lbs

When these roof racks are to be used on a vehicle that is driven off sealed roads, the manufacturer maximum roof load rating (to be found in the vehicles User Manual) should be **divided by 2**. Do not forget to subtract 5kg/11lbs from your maximum carrying capacity due to the weight of the crossbars and legs.

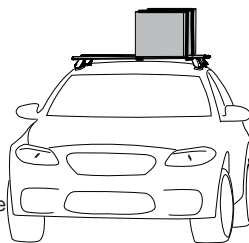

### Example

**60kg load rating** (Urban road) = **30kg load rating** (Off road = 60kg / 2)

**132lbs load rating** (Urban road) = **66lbs load rating** (Off road = 132lbs / 2)

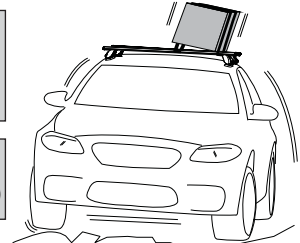

### WARNING! Important Load Carrying Instructions

With utility vehicles, the cabin and the canopy move independently. Roofracks and vehicle can be damaged if the item transported is rigidly fixed at points on both the cabin and canopy. Instead, rigidly fix to either the cabin roofracks or the canopy roofracks.

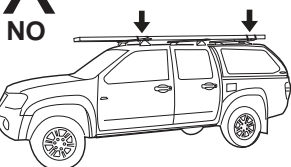

YES

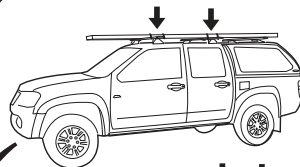

YES

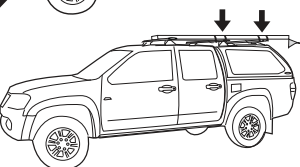

YES

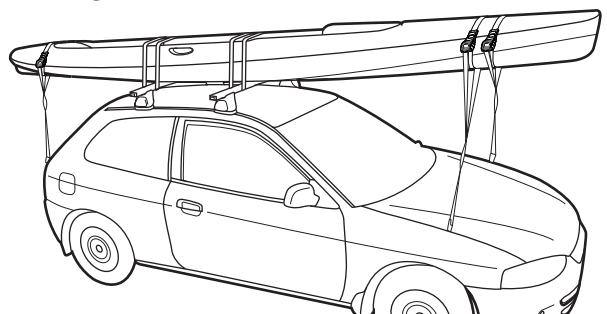

Kayaks must be secured both front and rear.  
Paddle/ Surfboards must be fixed to the front of the vehicle.



# Rhino 2500 series for Euro Crossbar.

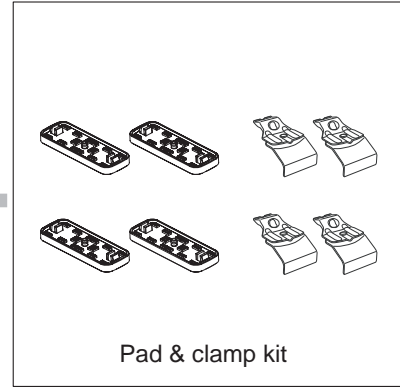
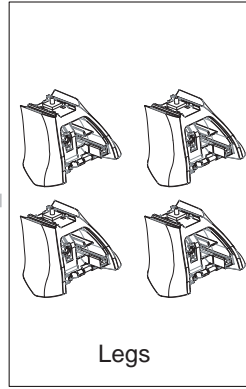

## Parts List

Item	Component Name	Qty	Part No.
1	Euro Crossbar	2	-
2	Euro End Cap	4	M460
3	Leg Cover Plate	4	M324
4	M8 x 50mm Security Bolt	4	B154
5	Measurement Strip	4	M641
6	Euro Crossbar Adaptor	4	M362
7	Leg	4	M310
8	Leg Cover Plate	4	M324
9	M6 Nut	4	N068
10	M6 Flat Washer	4	W003
11	M6 Spring Washer	4	W004
12	M6 x 20mm Socket Screw	4	B054
13	Foot Plate	4	M311
14	Front Cover Key	2	M314
15	Torque Allen Key	1	TORKEY-L
16	Location Decals	4	S365
17	Positioning Decals	4	S364
18	Fitting Instructions	1	RR226

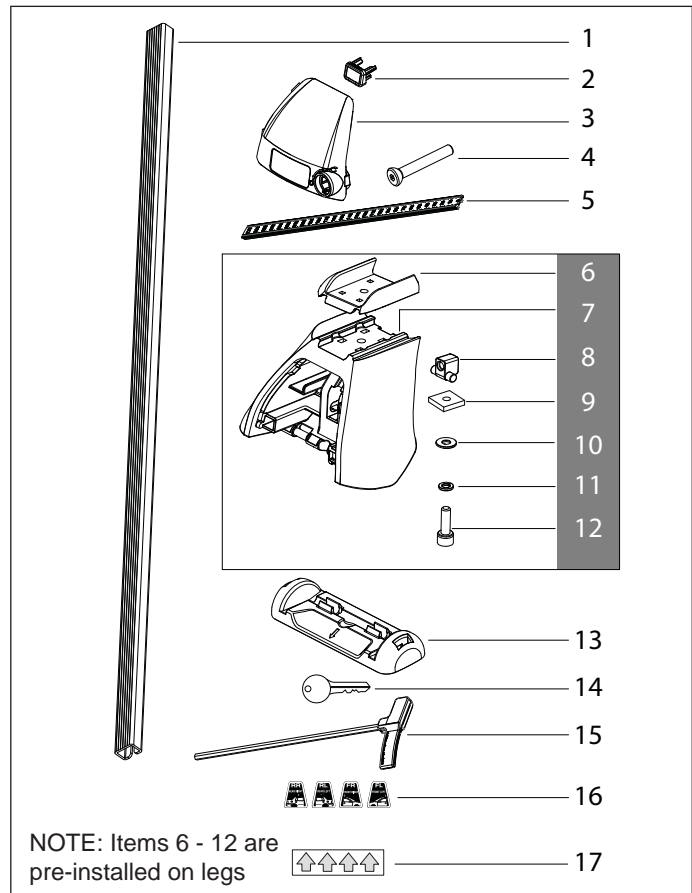

### Tools Required;

Torque key (inc. in kit) Side Cutters/Scissors, Tape Measure, Rubber Mallet.

**NOTE :** Refer to the DK kit specification sheet for correct placement (*Front & Rear, Left & Right*) of the foot plate, rubber pad and metal strap. Also refer for sizes to cut the bar measurement strips.

**1** Using the key provided, remove the Cover Plate from the Legs.

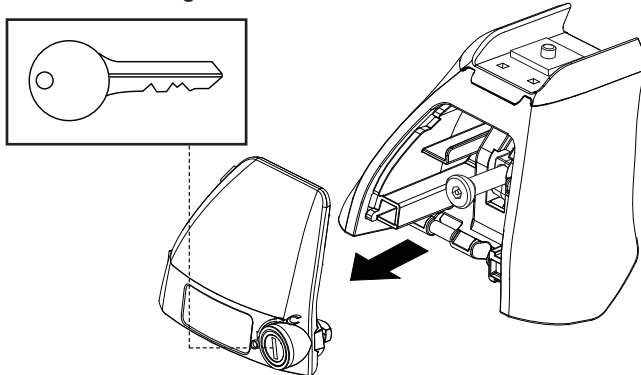

**2** The 2500 Legs will come with hardware assembled, however if the Pivot Nut is not attached to the leg, install as shown with the angled face of the nut facing outwards (as below).

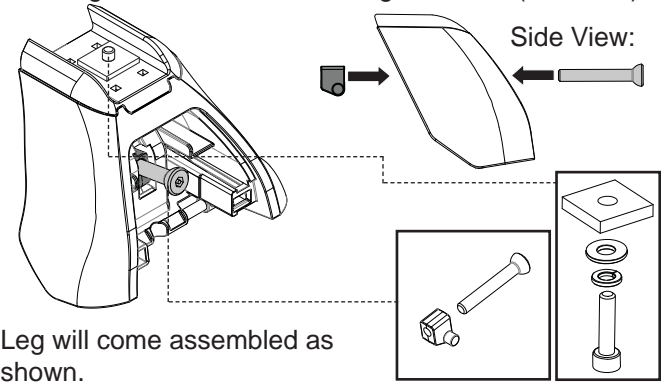



# Rhino 2500 series for Euro Crossbar.

## 3 Attach pad to foot plate.

Clip rubber pad onto foot plate. Pad central locator lug and end tabs must fully locate into the foot plate. Refer to DK Kit Specification Sheet for correct orientation under pad/clamp numbers.

DK spec sheet.

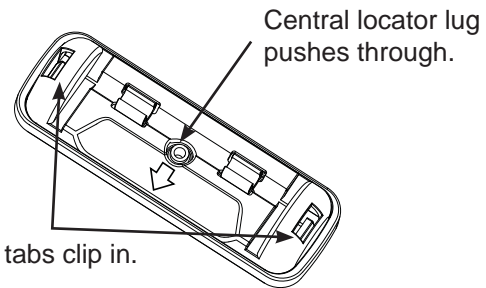
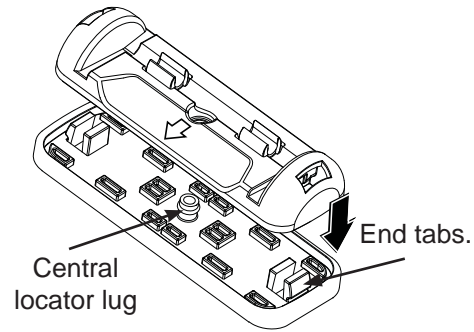
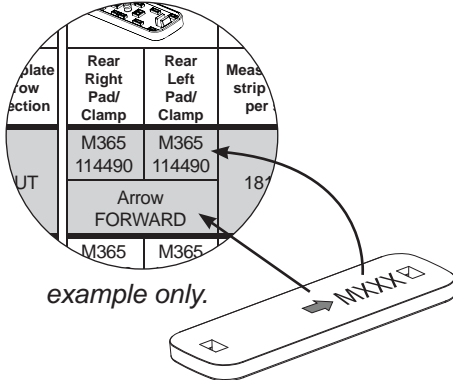

## Attach foot plate to leg.

With the pad correctly fitted to the foot plate as per the DK spec sheet, clip the foot plate onto the base of the leg with the arrow facing **In or Out** according to your vehicle listed in the DK Kit specification sheet.

DK spec sheet.

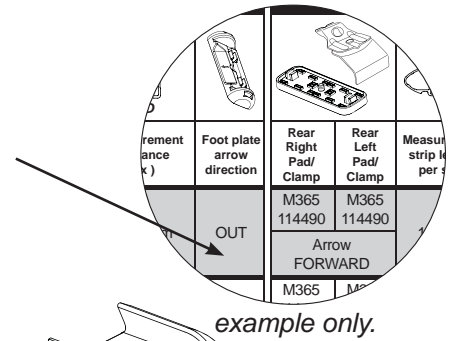

Example:

Attach foot plate to leg with arrow facing **OUT**

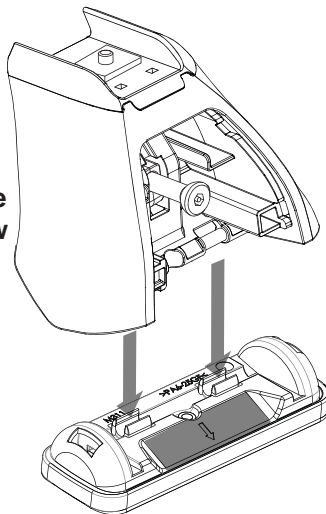

Example:

Attach foot plate to leg with arrow facing **IN**. Note: Facing **IN** is for a small number of vehicles.

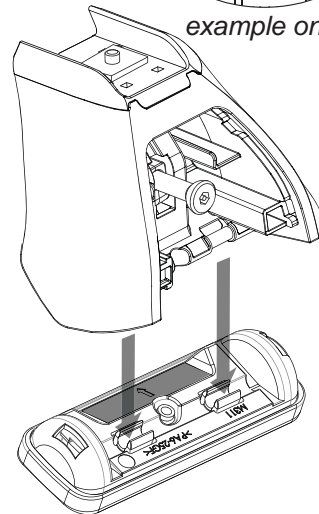

## 4

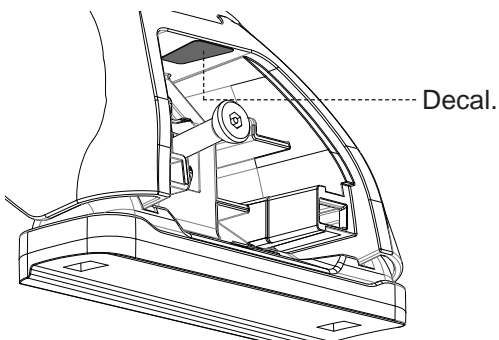

### Leg location decals:

Stick the leg position labels inside the leg. The labels identify the position of the leg on the vehicle roof. Use as a guide when re-fitting the crossbars after removal. Refer layout below.

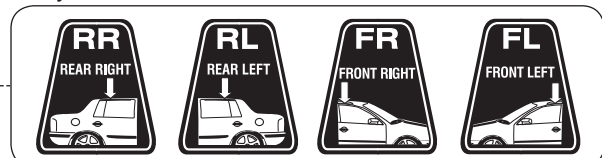



# Rhino 2500 series for Euro Crossbar.

## 5 Measurement strip length:

Refer to DK Specification Sheet for cut length of bar measurement strips.

*NOTE: front and rear bar generally have different lengths.*

a. Accurately cut measurement strips to length. Slide into each end of crossbar. Repeat for front & rear crossbar.

b. Locate M6 nut into the crossbar then slide leg in to butt up against the measurement strip.

c. The measurement strip must butt up against the end of the crossbar cut out. Tighten M6 security screw with the allen key provided. **Tighten to 4-5 Nm (2-3 lb/ft)**

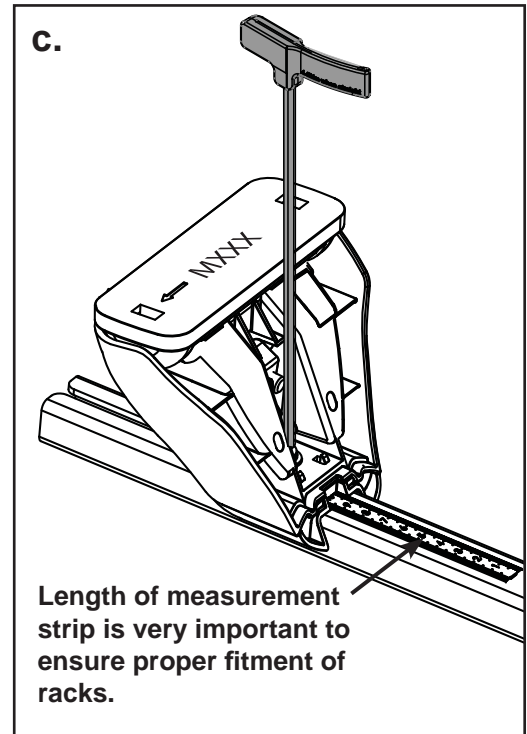
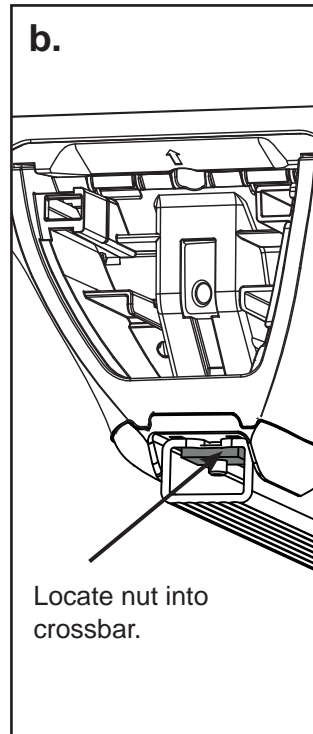
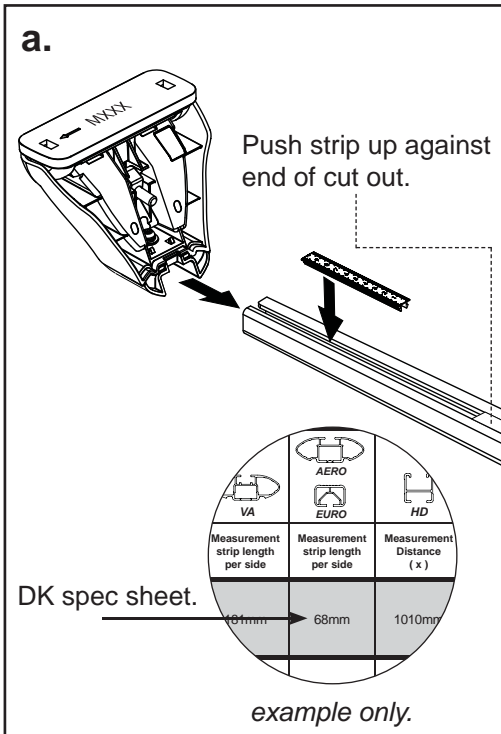

### Note:

The measuring strip sits flush against the leg as shown. Do not push the leg over the strip.

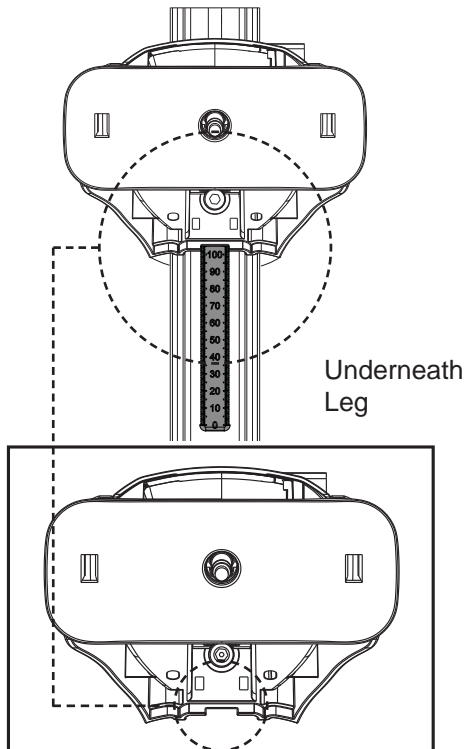

With Torque Key inserted, turn clockwise until handle straightens out as shown.

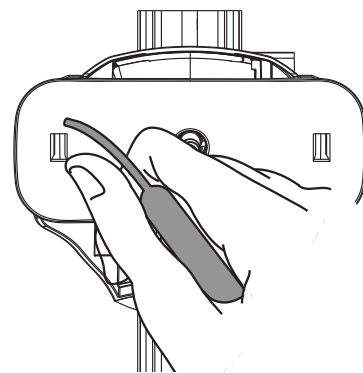

This indicates 4-5 Nm. More pressure may be required in extreme climates.

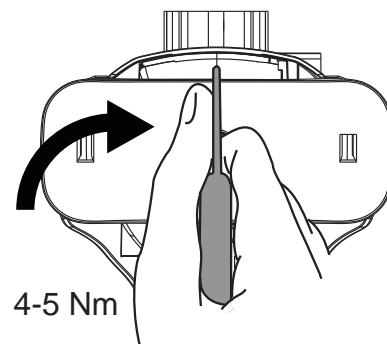



# Rhino 2500 series for Euro Crossbar.

**6** Slide the remaining measurement strip that corresponds to the inside length into the end of the crossbar. Repeat this for front and rear crossbars. Cut strips flush with end of crossbar if required.

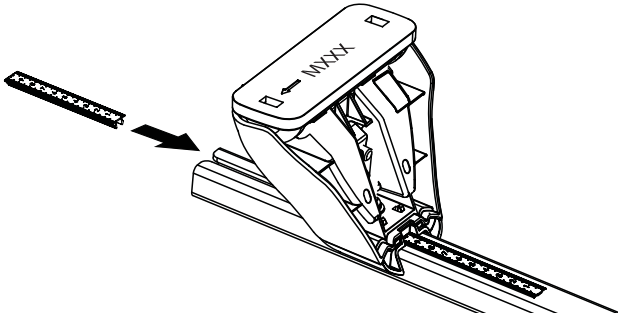

**7** Insert the end cap into the crossbar.

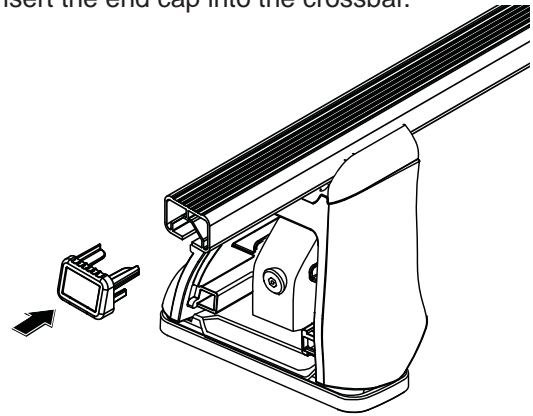

**8 Position roof racks:**

Place racks onto the vehicle roof.

Refer to DK specification sheet for correct positioning of your roof racks.

**A.** Measure forward from where the front and rear doors meet/close.

**B.** Measure back to set distance between crossbars, centre of front foot plate arrow to centre of rear foot plate arrow.

**A and B** measurements are to be in line with arrow in centre of foot plate.

DK spec sheet.

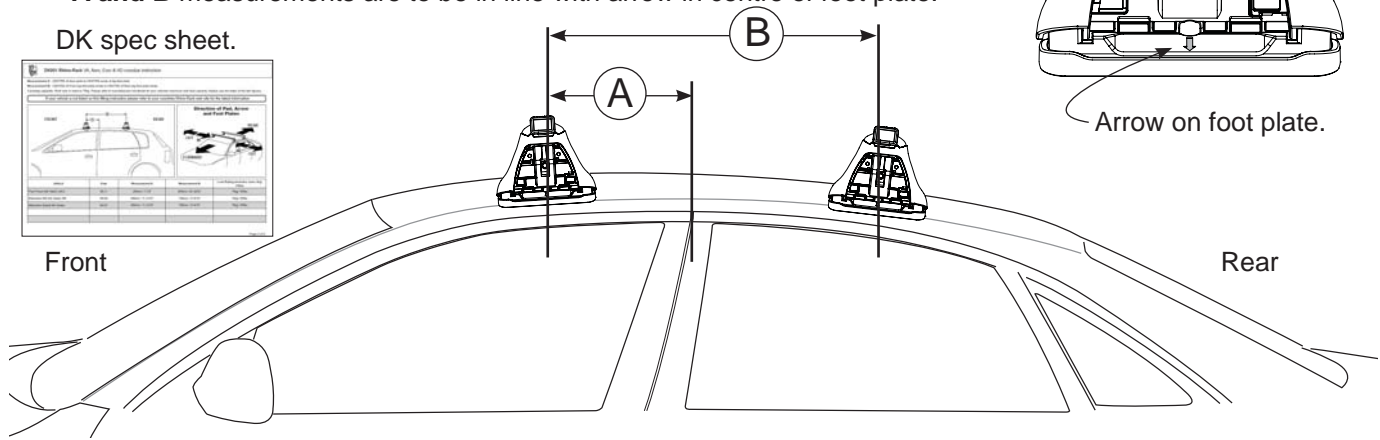
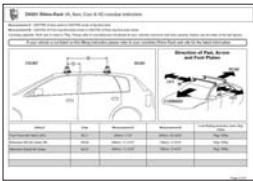

**9 Positioning decals:**

Stick the white arrow decals in line with foot plate arrows onto the body work inside the door jamb. This marks reference points for future use when racks are removed and then replaced.

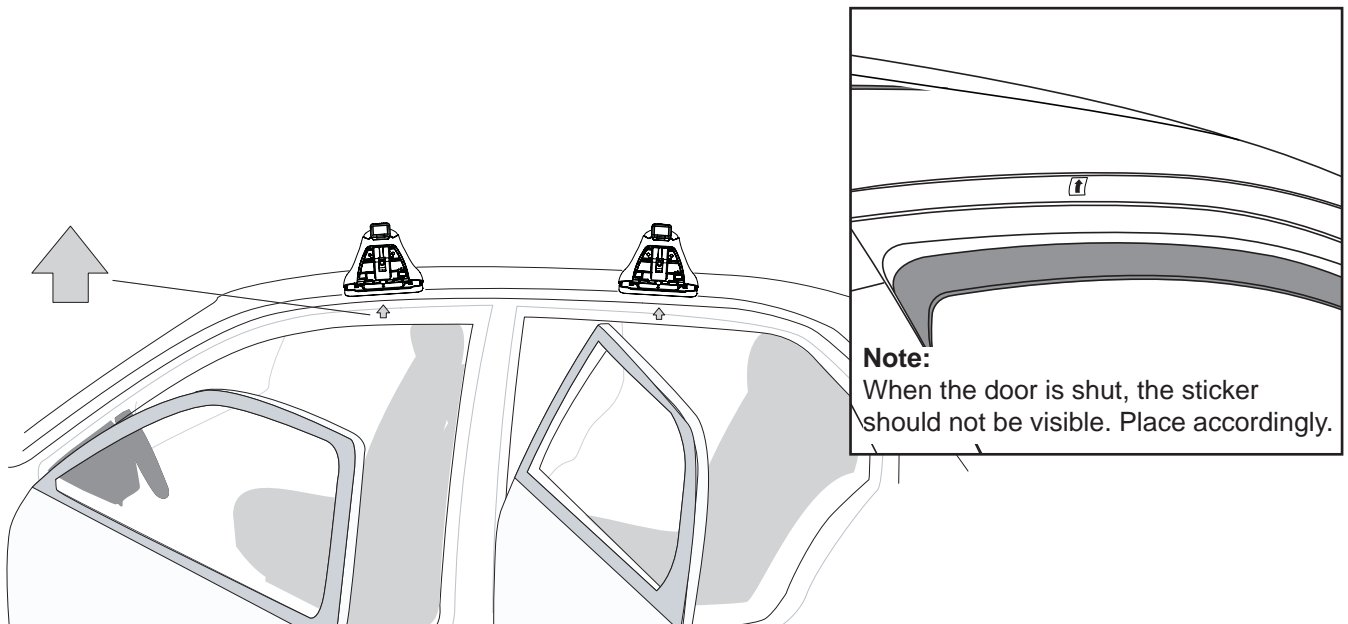

**Note:**  
When the door is shut, the sticker should not be visible. Place accordingly.



# Rhino 2500 series for Euro Crossbar.

10

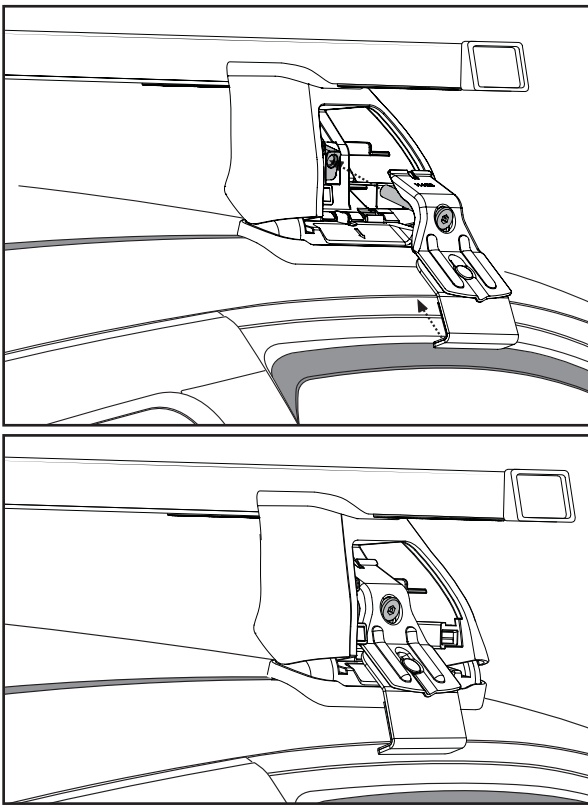

### Attach clamps:

Hook the lower part of the metal clamp in at the top of the door jamb. Fasten M8 bolt to pivot nut.

**Bolts must be tensioned evenly each side of the vehicle to avoid pulling the rack to one side.**

**Tighten to 4-5 Nm (35-44 lbf.in). DO NOT OVER TIGHTEN.**

Refer to DK instruction for correct clamp and pad combination for front and rear of vehicle.

Check that the assembly is tight by shaking the crossbars vertically and horizontally

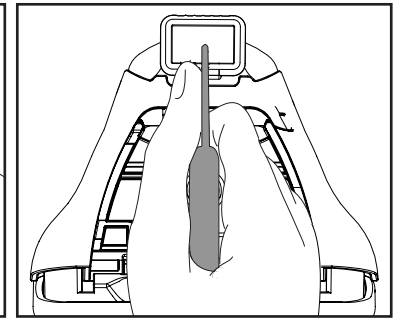
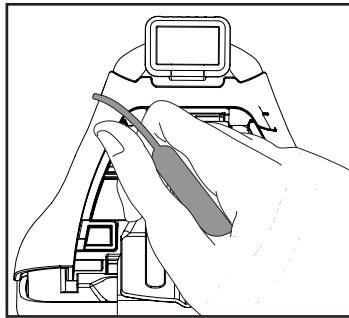
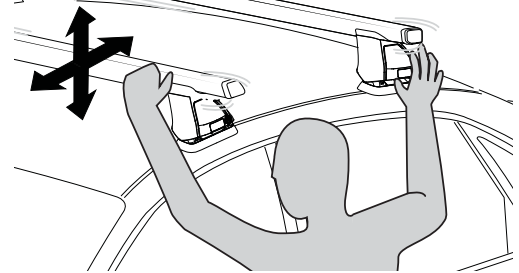

11

Visually inspect and ensure that the clamp is correctly seated against the body of the vehicle.

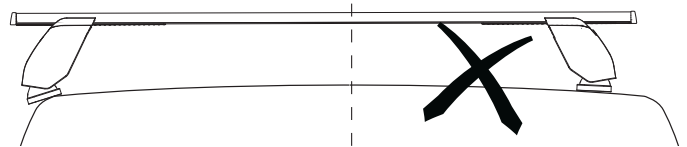
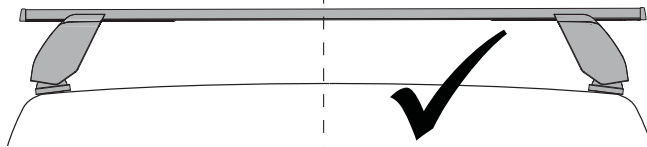

Side View: The clamp must have full contact along its face.

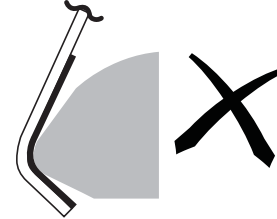
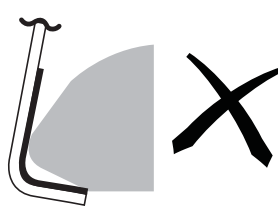
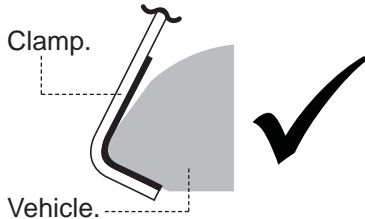

12

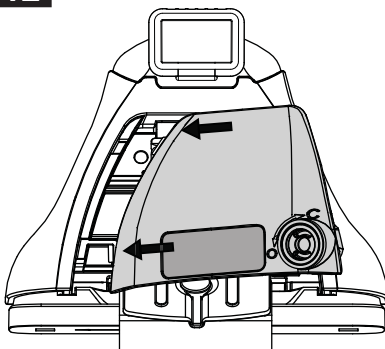

Front cover key



or



Plastic key

Locks use a slide window. The cover moves across the face of the barrel.

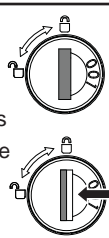

\*image shown with metal keylock

13

Insert the two lugs on left side of front cover into the leg. Use key provided to turn lock barrel to the open position (O). Engage locking tab into leg. Turn to close (C).

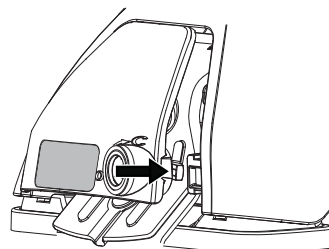

Open.

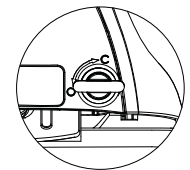

Closed.

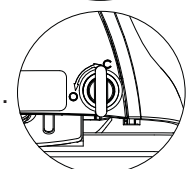

\*image shown with plastic keylock